

New York City Landmarks Preservation Commission

Jackson Heights

Historic District

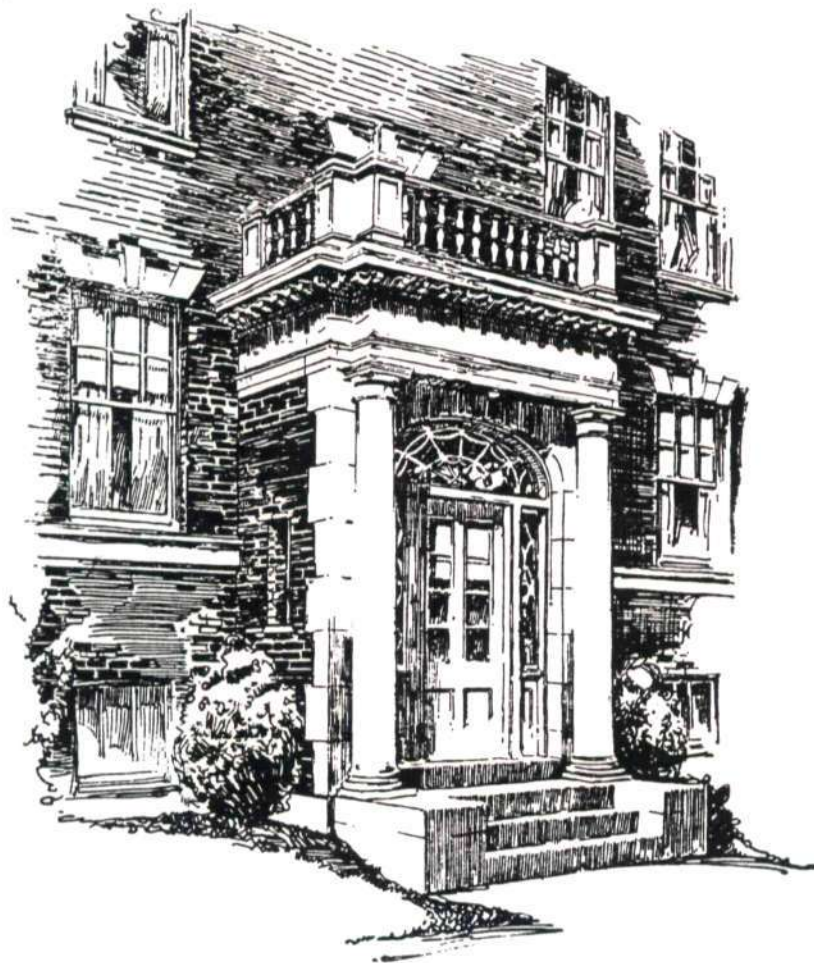

Elm Court

Jackson Heights, New York

October 19, 1993

New York City Landmarks Preservation Commission

JACKSON HEIGHTS HISTORIC DISTRICT

Prepared by the Research Department, Marjorie Pearson, *Director*

Editors: Elisa Urbanelli, *Research Department Editor*
Anthony W. Robins, *Director of Special Projects*

Research/Writing: Luella Adams
Joseph Brooks, Ph.D.
Donald Presa
James T. Dillon
Patricia Garbe
Anthony W. Robins

Graphics: Richard Brotherton

Report Layout: Marion Cleaver

The Landmarks Preservation Commission

Laurie Beckelman, *Chair*
Sarah Bradford Landau, *Vice-Chair*

William E. Davis
Ulrich Franzen
Jack S. Freeman
Hui Mei Grove
Rev. Thomas F. Pike
Stephen Raphael
Vicki Match Suna
Charles Sachs

Commissioners

**In memory of
Luella Adams
whose survey and research work
proved invaluable to the creation
of the Jackson Heights Historic District**

ACKNOWLEDGMENTS

The study of a potential historic district in the Jackson Heights area required the participation of many people over the course of several years. In 1987 Gene A. Norman, then Chairman, directed the Commission's Survey Department to undertake a survey of Queens Community Board 3 which includes Jackson Heights, Elmhurst, and Corona. This work was undertaken largely by Survey staff member Luella Adams and resulted in a report presented to the Commission, containing recommendations for potential historic districts and individual landmarks within the area of the Community Board. These recommendations were further reviewed by the Research Department. Commissioners began a series of field trips to and discussions of a potential Jackson Heights Historic District in 1990. The Commission subsequently calendared and heard at public hearing, under Chair Laurie Beckelman, a Jackson Heights Historic District. Following the public hearing, the Survey Department staff was directed to complete the research and prepare a draft designation report for the proposed district. Also participating in this effort was James T. Dillon of the Research Department.

The Commission wishes to express its thanks to the Jackson Heights Beautification Group for additional research help and for enabling Warren Shaw to photograph the buildings throughout the historic district. Thanks also to Thomas Langan, a long-time employee of the Queensboro Corporation, for making available his collection of historic photographs, brochures, and other printed material regarding Jackson Heights.

TESTIMONY AT THE PUBLIC HEARING	1
JACKSON HEIGHTS HISTORIC DISTRICT BOUNDARIES	1
INTRODUCTION	3
HISTORICAL BACKGROUND FOR DEVELOPMENT IN JACKSON HEIGHTS	7
PLANNING AND DEVELOPMENT OF JACKSON HEIGHTS	13
THE ARCHITECTURE OF JACKSON HEIGHTS	21
ILLUSTRATIONS	
Fig. 1. Plan of the Home and Tower Buildings, 1876-79.	39
Fig. 2. "Dumbbell" plan by James E. Ware.	40
Fig. 3. Plan of the City and Suburban Homes Company, Avenue A (York Avenue) Estate	41
Fig. 4. Yorkship Village, Camden, N.J. (Electus D. Litchfield, c. 1918)	42
Fig. 5. Union Park Gardens, Wilmington, Del. (Ballinger & Perrot, c. 1918).	43
Fig. 6. Edward A. McDougall (1874-1924), c. 1928.	44
Fig. 7. View of the Queensboro Corp.'s undeveloped land, c. 1909.	45
Fig. 8. Rowhouses (Charles Peck, 1911), east side of 83rd Street	46
Fig. 9. Laurel Court (George H. Wells, 1913-14) in c. 1916	47
Fig. 10. Willow Court (George H. Wells, 1915) in c. 1916	48
Fig. 11. Plan of Charlottenburg II Project (1907-09)	49
Fig. 12. 12 Hyde Park Place, London (Frank T. Verity, 1902-03)	50
Fig. 13. Plymouth Apartments (1916, George H. Wells)	51
Fig. 14. Floor plan of Plymouth Apartments	52
Fig. 15. Floor plan of Willow Court	53
Fig. 16. Greystone Apartments (George H. Wells, 1916-18), c. 1925	54
Fig. 17. Original plan of Linden Court (Andrew J. Thomas, 1919-21)	55
Fig. 18. Linden Court, c. 1925	56
Fig. 19. Hawthorne Court (George H. Wells, 1921-22), entrance detail, c. 1940	57
Fig. 20. Laburnum Court (George H. Wells, 1921-22), c. 1925	58
Fig. 21. Cambridge Court (George H. Wells, 1922), c. 1925	59
Fig. 22. View looking east on 34th Avenue, c. 1935	60
Fig. 23. Spanish Gardens (Andrew J. Thomas, 1924-26), c. 1935	61
Fig. 24. Plan for the Chateau (Andrew J. Thomas, 1922), c. 1921-22	62
Fig. 25. View looking south from the Towers showing a three-block long vista of the interior gardens of the Towers, the Chateau, and the Greystone Apartments, c. 1930	63
Fig. 26. Society of Cooperative Enterprises, Paris, illustration	64
Fig. 27. Garden Homes (C.F. & D.E. McAvoy, 1925) c. 1926	65
Fig. 28. Garden Homes (C.F. & D.E. McAvoy, 1926) c. 1926	66
Fig. 29. Garden Homes (C.L. Varrone, 1926)	67
Fig. 30. Garden Homes (Robert Tappan, 1926-27), c. 1930	68
Fig. 31. Plymouth Houses (Pierce Kiesewetter, 1928)	69
Fig. 32. Fillmore Hall (E. Adelsohn, 1930) in c. 1935, before rooftop alterations	70
Fig. 33. Georgian Hall (E. Adelsohn, 1930-31) in 1931	71
Fig. 34. Dunolly Gardens (Andrew J. Thomas, 1939), view of interior garden c. 1940 ...	72
Fig. 35. Community Methodist Church (F.P. Platt, 1920-23), c. 1925	73
Fig. 36. St. Joan of Arc R.C. Church (W.A. Schlusing, 1949-51)	74
Fig. 37. U.S. Post Office, Jackson Heights (Benjamin C. Flournoy, 1936-37)	75
Fig. 38. Queensboro Corporation Headquarters (Morrell Smith, 1928) c. 1935	76

NORTHERN BOULEVARD

South Side	75
34TH AVENUE	
North Side	76
South Side	77
35TH AVENUE	
North Side	83
South Side	90
37TH AVENUE	
North Side	99
South Side	106
ROOSEVELT AVENUE	
North Side	114
76TH STREET	115
East Side	115
77TH STREET	
East Side	117
West Side	119
78TH STREET	
East Side	120
West Side	125
79TH STREET	
East Side	127
West Side	133
80TH STREET	
East Side	134
West Side	141
81ST STREET	
East Side	142
West Side	145
82ND STREET	
East Side	147
West Side	159
83RD STREET	
East Side	165
West Side	174
84TH STREET	
East Side	181
West Side	188
85TH STREET	
East Side	190
West Side	197
86TH STREET	
East Side	198
West Side	205
87TH STREET	
East Side	208
West Side	216
88TH STREET	
West Side	221
FINDINGS AND DESIGNATION	226

TESTIMONY AT THE PUBLIC HEARING

On December 4, 1990, the Landmarks Preservation Commission held a public hearing in the auditorium of Intermediate School 145, 33-34 80th Street, Jackson Heights, Queens, on the proposed designation of the Jackson Heights Historic District (Item No. 12). The hearing had been duly advertised in accordance with the provisions of law. Fifty people offered testimony in support of the proposed designation, including representatives of Queens Borough President Claire Shulman, State Assembly members Helen Marshall and Ivan C. Lafayette, Congressman Tom Manley, and Community Board 3, the Jackson Heights Beautification Group, the Queensborough Preservation League, the Historic Districts Council, and the Municipal Art Society. Many residents and property owners within the proposed historic district expressed support for the designation. Seven speakers expressed opposition to the inclusion of any religious structures within the historic district; five expressed concerns about the effects of designation on building maintenance; and one spoke against the designation of the entire district. The Commission has received many letters expressing support for the designation of the historic district. A few letters have been received opposing designation of the historic district or the inclusion of certain properties within the historic district.

JACKSON HEIGHTS HISTORIC DISTRICT BOUNDARIES

The Jackson Heights Historic District in the Borough of Queens consists of the property bounded by a line beginning at the southeast corner of the intersection of 78th Street and 34th Avenue, then extending southerly along the eastern curbline of 78th Street, westerly along the southern curbline of 35th Avenue, southerly along the eastern curbline of 77th Street, westerly across 77th Street, westerly along the northern property lines of 35-14 77th Street and 35-13 76th Street, southerly along the eastern curbline of 76th Street, easterly along the southern property lines of 35-55 76th Street and 35-56 77th Street, easterly across a portion of 77th Street, southerly along a line extending to the eastern curbline of 77th Street beginning at the southeast corner of 77th Street and 37th Avenue, southerly along the eastern curbline of 77th Street, easterly along the southern property line of 37-01 78th Street (a/k/a 78-02 37th Avenue/37-02 79th Street), easterly across 78th Street, southerly along the eastern curbline of 78th Street, easterly along the southern property lines of 37-57 78th Street and 37-58 79th Street, easterly across 79th Street, easterly along the southern property lines of 37-55 79th Street and 37-52--37-56 80th Street, northerly along the western curbline of 80th Street, easterly across 80th Street, easterly and northerly along the southern and eastern property lines of 37-15--37-21 80th Street, easterly along the southern property line of 37-20--37-22 81st Street, northerly along the western curbline of 81st Street, easterly across 81st Street, easterly along the southern property lines of 81-02--81-28 37th Avenue (a/k/a 37-01--37-09 81st Street/37-06--37-10 82nd Street), southerly along the western property lines of 37-12--37-34 82nd Street through 37-70 82nd Street (a/k/a 81-11--81-19 Roosevelt Avenue), easterly along the northern curbline of Roosevelt Avenue, northerly along the eastern property line of 82-01 Roosevelt Avenue (a/k/a 37-61--37-67 82nd Street), easterly along the southern property line of 37-60 83rd Street, easterly across 83rd Street, easterly along the southern property line of 32-16--37-58 84th Street (a/k/a 37-15--37-57 83rd Street), easterly across 84th Street, easterly along the southern property lines of 37-55--37-59 84th Street and 37-56--37-60 85th Street, easterly across 85th Street, easterly along the southern property lines of 37-57 85th Street and 37-58 86th Street, northerly along the western curbline of 86th Street, easterly across 86th Street, easterly along the southern property line of 86-02--86-20 37th Avenue (a/k/a 37-01--37-09 86th Street/37-02--37-10 87th Street), easterly across 87th Street, southerly along the eastern curbline of 87th Street, easterly along the southern property line of 35-57 87th Street, northerly along the eastern property lines of 37-57 through 37-11 87th Street, easterly along part of the southern property line of 87-02--87-10 37th Avenue (a/k/a 37-01 87th Street/37-02--37-10 88th Street), northerly along the western curbline of 88th Street, westerly along the northern property lines of 34-14 88th Street

and 34-13 87th Street, westerly across 87th Street, westerly along the northern property lines of 34-14 87th Street and 34-15 86th Street, westerly across 86th Street, westerly along the northern property lines of 34-16 86th Street and 34-15--34-41 85th Street, westerly across 85th Street, northerly along the western curbline of 85th Street, westerly along the northern property lines of 34-14 85th Street and 34-11 84th Street, westerly across 84th Street, northerly along the western curbline of 84th Street, westerly along the southern curbline of 34th Avenue, westerly across 83rd Street, northerly along the western curbline of 83rd Street, westerly along the northern property line of 33-54 83rd Street (a/k/a 82-17 34th Avenue), northerly along the eastern property lines of 33-33 82nd Street to 33-11 82nd Street, westerly along the northern property line of 33-11 82nd Street, northerly along the eastern property line of 33-01--33-05 82nd Street, westerly along the southern curbline of Northern Boulevard, southerly along the eastern curbline of 82nd Street, westerly across 82nd Street, westerly, southerly and westerly along the northern property line of 33-50 82nd Street (a/k/a 81-01--81-11 34th Avenue/33-53 81st Street), westerly across 82nd Street, northerly along the western curbline of 81st Street, westerly along the northern property line of 33-16--33-52 81st Street (a/k/a 33-15--33-51 80th Street/80-01 34th Avenue), southerly along the eastern curbline of 80th Street, westerly across 80th Street, westerly along the northern property lines of 34-28 80th Street and 34-27 79th Street, westerly across 79th Street, northerly along the western curbline of 79th Street, westerly along the southern curbline of 34th Avenue to the point of beginning.

JACKSON HEIGHTS HISTORIC DISTRICT

Introduction

The Jackson Heights Historic District comprises the most cohesive part of an innovative residential development which was mostly built between the early 1910s and the early 1950s. This development reflects important changes in urban design and planning that took place in the first three decades of the twentieth century. Conceived, planned, built in part, and managed under the direction of a single real estate firm, the Queensboro Corporation, and its president Edward A. MacDougall, Jackson Heights is one of the earliest neighborhoods in New York to introduce two new building types, "garden apartments" and "garden homes." Commercial, institutional, recreational and transportation facilities were integrated with the residential buildings to create an alternative for middle-class residents to the then typical urban neighborhood. Influenced in its planning and management by a number of sources including the "model tenement" or improved housing movement in New York City at the end of the nineteenth century and the "Garden City" movement at the beginning of this century, Jackson Heights generated both national and international interest.

Development of Jackson Heights was spurred by such transportation improvements as the opening of the Queensboro Bridge in 1909, the extension of the subway as far as Flushing (the elevated train line along Roosevelt Avenue opened in 1917), the construction of the Independent subway line in the 1930s, and the rapid growth of Long Island City as one of the city's largest manufacturing centers. Soon after acquiring an extensive tract of farmland in the Trains Meadow section of Newtown in northwest Queens in 1910, the Queensboro Corporation began to improve its property. The earliest projects located within the district are the row of houses (1911) by architect Charles Peck on the west side of 83rd Street just north of Roosevelt Avenue, and Laurel Court (1913-14, George H. Wells), the first apartment complex, located at the southeast corner of Jackson Avenue (now Northern Boulevard) and 82nd Street. These buildings followed in the tradition of late nineteenth-century housing and provide the historical context for understanding the innovative nature of the Corporation's later work.

Following these early projects, the Queensboro Corporation initiated in Jackson Heights an important planning concept, developed from ideas and examples of the model housing movement of the nineteenth century, which involved the treatment of the rectangular block created by the street grid system as a single unit of planning and design, rather than as a collection of individual building lots to be developed independently. This design concept is seen in the area's "garden apartments" of the 1910s and 1920s, which are among New York's earliest examples of this type of apartment house, and in the "garden homes," clusters of attached and semi-detached houses which were built after 1924.

Although a number of architects worked for the Corporation, the two most influential in the evolution of the garden apartment type were George H. Wells and Andrew J. Thomas. The Greystone Apartments (1917-18) on 80th Street between 35th and 37th avenues, designed by Wells, mark a departure from the architect's earlier Laurel Court in the reduction of lot coverage and allocation of garden space. The buildings are arranged in rows on two facing blockfronts, creating uniform streetscapes of unbroken masonry facades along both sides of the street; continuous landscaped garden areas are provided at the rear of each blockfront. A different planning scheme was introduced by Thomas with his design of Linden Court (1919-21), located on 84th and 85th streets between 37th and Roosevelt avenues. In this complex, the buildings are grouped into attached pairs; the building wall on the periphery of the block is interrupted at regular intervals by open space. The interior of the block is an undivided landscaped space, held in common by means of easements and deed restrictions for the benefit of the residents. This type of plan creates cross ventilation, increased light, and views from the street to the landscaped garden, and encourages a sense of community. The idea of community was

strengthened by the Corporation's introduction in 1919 of a plan for the cooperative ownership of the buildings in the garden apartment complexes. Other notable examples of this type of block treatment designed by Thomas include the Chateau (1922), on 80th and 81st streets south of 34th Avenue, and the Towers (1923), on the block directly to the north. Characteristic examples of Wells's garden apartment complexes include Hawthorne Court (1921-22), located on 76th and 77th streets between 35th and 37th avenues, and Cambridge Court (1922-23), located on 85th and 86th streets between 37th and Roosevelt avenues.

The garden apartment buildings in the district are executed in brick and are rendered in a number of architectural styles derived from French, English, Italian, and Spanish sources, generally combining simple facade treatments with such picturesque elements as loggias, belvederes, tile and slate roofs, and decorative brickwork. Their overall simplicity of design reflects the movement in the first decades of this century away from the extensive use of ornament which had been popular during the late nineteenth century. The apartment buildings were constructed with a number of features considered novel at the time such as automatic push-button elevators, sun porches, and, at Linden Court, ground-level garages.

With the exception of the group of houses built in 1911, the construction of single-family (and "convertible" two-family) houses in the district was begun in the 1924. The most prolific architects of houses within the district were Robert Tappan and C.F. & D.E. McAvoy, who applied some of the planning concepts of the "Garden City" movement to the design of homes in Jackson Heights. Based on English precedents from the beginning of the century, the ideas of the "Garden City" movement had been implemented in this country in such developments as Forest Hills Gardens (begun 1909, Grosvenor Atterbury and Frederick Law Olmsted, Jr.) and in government-sponsored developments of the World War I era. One result of these planning efforts was the "garden home," featuring an amalgam of up-to-date conveniences and traditional design.

The attached and semi-detached houses in Jackson Heights, whose design was derived largely from such English sources as Georgian and Tudor architecture, form picturesque ensembles distinguished by varied materials and roof treatments. The blocks containing the houses were, like the "garden apartments," treated as harmonious design units. The rows of attached houses are set back from the building line behind front yards and broken at regular intervals by broad open spaces into discrete groups of between four and eight houses each; the semi-detached houses are grouped into pairs. The open spaces provide a system for interior circulation and increased natural light similar to that of the garden apartment complexes. The spaces between the groups of houses also allow views from the street into the interior of the block, greatly increasing the sense of open space from the public street. Garages were included either under the rear of the houses, allowing a block-long greensward at the interior of the block, or a paved alley was laid down the center of the block and lined with garages designed in the styles of the houses; the pairs of houses often have attached garages. Jackson Heights is one of New York's earliest communities in which residential buildings were designed with the automobile in mind.

Apartment buildings continued to be built in Jackson Heights during the 1930s and 1940s; many of the buildings from this period were constructed along 35th Avenue, terminating the ends of the street blocks. Largely six stories in height, these buildings are characterized by their consistent massing and demonstrate various planning schemes around lightcourts and courtyards. Like the earlier garden apartments, many of these buildings were designed with a modest application of traditional architectural features while others reflect more modernistic trends. Dunolly Gardens (Thomas, 1939), located on the block bounded by 34th and 35th avenues and 78th and 79th streets, is a later example of the characteristic garden apartment complex, yet given a modernistic architectural treatment. Following World War II, buildings were constructed on previously undeveloped lots within the district and these buildings show

sensitivity to the existing community. Siting, height, massing, scale, and materials of the post-war buildings harmonize with the earlier fabric of the area.

Institutional buildings such as houses of worship as well as commercial buildings were also built in Jackson Heights, enhancing the sense of a self-sufficient town within the larger city. The intersection of 37th Avenue, the commercial spine of the district, and 82nd Street, another important commercial street, is distinguished by a group of picturesque neo-Tudor style commercial buildings dating from between the World Wars. The district is among the earliest areas in the city in which the commercial thoroughfares were planned to complement and integrate with the residential buildings by using the same architectural styles or by incorporating features of adjoining residential buildings into their designs. Among the institutional buildings included within the district are a public school (P.S. 69, C.B.J. Snyder, 1924), a post office (Benjamin C. Flournoy, 1936-37), and a branch of the Queens Borough Public Library (S. Keller, 1949-52). At one time, a broad mall was planted down the center of 34th Avenue which led to the community's country club, tennis courts, and golf course, all of which are no longer extant.

The Queensboro Corporation's planned community at Jackson Heights was recognized at the time of its development as one of New York's important centers of new housing concepts, particularly the "garden apartment," and many of the ideas and features explored there are now standard for middle-class housing. From the time of its development, Jackson Heights attracted middle-class families desiring a convenient, pleasant alternative to the typical urban neighborhood. Today, Jackson Heights continues to be a vibrant community which, because of its overall design, planning, and integration of open space, as well as its high degree of intactness, has a strongly defined sense of place.

Page intentionally left blank

HISTORICAL BACKGROUND FOR DEVELOPMENT IN JACKSON HEIGHTS

The development of Jackson Heights as a planned community of garden apartments and houses must be understood in the context of the work, toil, and effort of many citizens -- social reformers, philanthropists, critics, and architects -- during the nineteenth century and early twentieth century to address and alleviate the inferior housing conditions in New York. What developed were new forms of housing for both the working poor and the middle class.

Housing Reform: Model Tenements¹

For the poor, the housing situation during the first half of the nineteenth century had deteriorated to an appalling level. Not only were people packed together in concentrations unequalled in any American or European city, but the poorly-constructed apartments they lived in had little light, less air, and no indoor plumbing. A report by the Association for Improving the Condition of the Poor, a charitable organization founded in 1843, argued that:

The tenements of the poor in this city are generally defective in size, arrangement, supplies of water, warmth, and ventilation. ...The occupants consequently, often suffer from sickness and premature mortality; their ability for self-maintenance is thereby impaired or destroyed, social habits and morals are debased, and a vast amount of wretchedness, pauperism and crime is produced.²

Motivated both by fear of disease and by humanitarian concerns, housing reformers began organizing in the early 1840s to attack the problem of the slums. From the first they took a two-pronged approach, lobbying for the enactment of housing and sanitary codes, and building "model tenements" which they hoped would demonstrate the feasibility of hygienic, comfortable housing, provided with ample natural light and ventilation, yet made affordable to the working poor.

Almost invariably, the sponsors of model tenements sought out innovative designs to make better use of Manhattan's typical city lot, a twenty-five by 100-foot rectangle within a larger rectangular block of about 200 by 800 feet, with the long sides of the block on the east-west axis.³ This grid system, mandated in the 1811 Commissioners' Plan for mapping streets in Manhattan above 14th Street, was considered at the time to be economically rational and profitable, as it was suitable for the small, single-family, brick rowhouse that was the common residential building type at that time. However, with widespread immigration in the 1840s, unprecedented pressure was placed on the existing housing stock and the limitations of the grid system and its standard lot dimensions became evident. As subdivided

¹The information in this section is based in part on Robert W. DeForest and Lawrence Veiller, eds., *The Tenement House Problem* (New York: Macmillan, 1903); James Ford, *Slums and Housing*, 2 vols. (Cambridge, Mass.: Harvard University Press, 1936); Richard Plunz, *A History of Housing in New York City* (New York: Columbia University Press, 1990); Elizabeth Collins Cromley, *Alone Together: A History of New York's Early Apartments* (Ithaca: Cornell University Press, 1990); Landmarks Preservation Commission, *City and Suburban Homes Company, Avenue A (York Avenue) Estate*, report prepared by Gale Harris (New York, 1990); and Elizabeth Blackmar, *Manhattan for Rent, 1785-1850* (Ithaca: Cornell University Press, 1989).

²Cited in LPC, *City and Suburban Homes*, 4.

³For problems inherent in the grid system see M. Christine Boyer, *Manhattan Manners: Architecture and Style 1850-1900* (New York: Rizzoli, 1985), 8-26.

rowhouses were inadequate to meet the city's housing needs, tenements were built on lots of the same size, creating long and narrow apartments with windowless interior rooms. The orientation of the blocks -- so that buildings along the long sides of the blocks fronted either north or south -- allowed only one narrow side of a building to receive direct sunlight. Also, no provision was made for service alleys to allow access to the interior of a block.

In the 1850s philanthropic housing activists began building projects to demonstrate in bricks and mortar their basic theories about improved housing. In addition, reformers successfully lobbied the government for minimum, though ultimately inadequate, sanitary and fire codes, and in 1867 the state legislature passed "An Act for the regulations of Tenement and Lodging Houses in the Cities of New York and Brooklyn." The next decade brought renewed interest in model tenements and new legislation.

Among the most successful model tenement projects of the 1870s were those built in Brooklyn for Alfred T. White and designed by William S. Field. Based on English prototypes, White's Home and Tower Buildings were erected in Cobble Hill in 1876-77 and 1878-79, respectively (the buildings are extant). These buildings were not only superior in design to any previous or contemporary efforts, but White was able also to prove that decent housing for the working poor could be financially successful. However, White's work was not widely imitated [Fig. 1].

As White's projects were being completed in Brooklyn, a competition sponsored in December, 1878, by a new publication, *The Plumber and Sanitary Engineer*, produced a highly influential solution to the tenement problem, known as the "dumbbell plan," by architect James E. Ware. Designed to eliminate windowless interior rooms, this plan called for buildings which narrowed at the center to create side shafts so that light and air would reach the inner bedrooms [Fig 2]. The Tenement House Law of 1879 mandated buildings to cover no more than sixty-five percent of their lots and favored the Ware dumbbell plan, but the law was not strictly enforced.

During the 1880s, a number of model tenements were built incorporating the lightcourt, a feature found in contemporary, early apartment buildings for the wealthy and middle classes. The lightcourt, a space enclosed on three sides by the building with the fourth side opening onto a street or unencumbered rear yard, had been employed over a decade earlier by Richard Morris Hunt at the Stuyvesant Apartments (1869-70, demolished) on East 18th Street. The 1890s saw a further advancement in the design of the tenement with the introduction of the central courtyard, a feature which was first employed in New York City in the design of the Astor House, a luxury hotel built in 1834 on lower Broadway opposite City Hall Park, and later used in the plan of Richard Morris Hunt's Studio Building (1857, demolished) on West 10th Street. One of the earliest proposals for the use of the courtyard plan in a tenement design was made by the architect Nelson Derby in 1877. However, it was not until after the publication of an article in *Scribner's Magazine* in 1894 by Beaux-Arts trained architect Ernest Flagg, that buildings for the working class were actually built with this feature.⁴

Flagg, who once called the street grid "the greatest evil which ever befell New York City,"⁵ proposed combining four standard twenty-five by 100-foot lots into a single unit of 100 by 100 feet, large

⁴See Mardges Bacon, *Ernest Flagg: Beaux-Arts Architect and Urban Reformer* (New York: Architectural History Foundation and Cambridge, Mass: M.I.T. Press, 1986), 234-266. The article is Ernest Flagg, "The New York Tenement-House Evil and Its Cure," *Scribner's Magazine* 16 (July, 1894), 108-117; also included in *The Poor in Great Cities* (New York: Charles Scribner's Sons, 1895), 370-392.

⁵Flagg, "The New York Tenement-House Evil and its Cure," in *The Poor in Great Cities*, 370.

enough for a roughly square building with a central courtyard entered through a passage from the street and allowing an open area around the sides and rear. The plan, derived from those of French apartment houses and tenements, provided for more space, light, and ventilation than did Ware's 1879 dumbbell plan. Flagg's plan had an impact on the standards for tenement construction mandated by the Tenement House Law of 1901, under which lot coverage was permitted up to seventy percent, while the minimum dimensions of air shafts and courtyards were increased. The law was important in moving architects and developers toward the design of residential complexes that occupied an entire city block.

Flagg's model and the new law influenced the work of the City and Suburban Homes Company, the most successful of the limited-dividend housing corporations founded in the nineteenth century. The best example of the development of an entire city block based on Flagg's proposal is City and Suburban's largest and most famous low-income housing project, the Avenue A (York Avenue) Estate (1900-1913) between York Avenue, the East River, and East 78th and East 79th streets, an important achievement in the housing movement [Fig. 3]. The Company attributed its success to three factors: careful, economical management that emphasized good tenant relations; efficient architectural planning that produced buildings with the largest possible rental space; and large-scale production. This policy was a paradigm for later builders and developers such as the Queensboro Corporation, a firm which looked to successful examples of model tenement design, planning, and management for its own large-scale ventures in middle-class housing.

The "Garden City" Movement

In the design and interior layout of tenements and multiple dwellings, many improvements had been made throughout the nineteenth century, yet little change had taken place in the interior arrangement of the rowhouse. Traditionally, the single-family rowhouse in New York City was entered at the parlor level by way of a stoop set to one side, and was two rooms deep with a side stair hall. Later in the nineteenth century, architects introduced the American basement plan, which provided a central entrance at ground level or a few steps above, creating a wide reception hall at the interior. Architects began to experiment with alternatives to the traditional rowhouse plan toward the end of the century.⁶ As housing demands increased, architects and developers also began to design and build rowhouses specifically for two families, contrasting with the usual practice of subdividing single-family rowhouses into multiple dwellings.

The most important influence on rowhouse planning and design in the early twentieth century was the "Garden City" movement, a regional planning concept for laying out suburban areas, first proposed by British housing reformer Ebenezer Howard in his book *Tomorrow, a Peaceful Path to Real Reform* (1898), reprinted in 1946 as *Garden Cities of Tomorrow*. Howard's ideas became familiar to Americans with the construction outside of London of Letchworth (begun 1903) by Sirs Raymond Unwin and Richard Barry Parker. The Garden City Association was founded in this country in 1906 to promote Howard's principles of town planning. The first area in New York City to be planned and designed under the influence of Howard's ideas was Forest Hills Gardens (begun 1909) by architect Grosvenor Atterbury and landscape architect Frederick Law Olmsted, Jr. The Garden City movement bears a relationship to the influential nineteenth-century planning concept of the American Romantic Suburb which incorporated certain elements: a railroad station (often located at the core of a village), a picturesque, curving street pattern, and naturalistic landscaping. While nineteenth-century Romantic

⁶For changes in the interior layout of rowhouses see Sarah Bradford Landau, "The Rowhouses of New York's West Side," *Journal of the Society of Architectural Historians* 34, no. 1 (Mar., 1975), 19-36.

Suburbs are generally exclusive enclaves with large, freestanding houses, Garden City communities incorporate clusters of houses, among other building types, along the tree-lined streets.

During World War I, the Federal Government was forced to initiate a building program to house workers in war-related industries. Two of the most influential government agencies established were the Emergency Fleet Corporation of the United States Shipping Board and the Department of Labor's United States Housing Corporation. The U.S. Shipping Board was begun in 1917 to encourage the expansion of the country's merchant marine; when the country entered the war, the Board established the Emergency Fleet Corporation which financed the expansion of shipyards and was charged with providing public transportation to them and, when necessary, housing for the workers.⁷ Among the architects who worked in the design section of the housing division were Daniel Kohn, Henry Wright, Frederick Ackerman, Clarence Stein, Lafayette Goldstone, and Andrew Jackson Thomas (whose important work on Jackson Heights garden apartments is discussed below).

By the war's end, the Emergency Fleet Corporation had carried out thirty-one housing developments across the country financed by a Congressional appropriation of \$75,000,000. These developments, which included houses, apartments, hotels, and dormitories, were notable for their planning inspired by the Garden City movement. In projects such as those at Yorkship Village in Camden, New Jersey (Electus D. Litchfield), Union Park Gardens in Wilmington, Delaware (Ballinger & Perrot), and Sun Village in Chester, Pennsylvania (Ernest Flagg), the architects experimented with grouping houses into discrete units of three to eight houses within a suburban setting (following Garden City precedents), and experimented with a variety of floor plans for these houses. In many designs, the separate entry hall and stair hall -- typical of the New York City rowhouse layout -- were eliminated, thus opening up the interior and providing greater floor area for living space. Often these houses were entered from porches or small enclosed entries directly into the living room; the staircase was along a side wall, tucked around a corner, or centrally placed to separate the living room from the dining room and kitchen. Such open layouts were used in the attached and semi-detached houses of Jackson Heights [Figs. 4 and 5].

After the war, the government divested itself of the projects of both the U.S. Housing Corporation and the Emergency Fleet Corporation, selling them to the shipbuilding companies, as well as private individuals, on a deferred payment plan. An essay published in 1920 that served as an introduction to the work done by the Emergency Fleet Corporation expressed an attitude held by many toward government-funded housing:

Many of the plans were made by architects imbued with the 'Garden City Idea,' and, while they are attractive for general suburban development, are too ambitious and expensive for practical dwellings for the general run of workmen....⁸

⁷For more information see the United States Department of Labor, Bureau of Industrial Housing and Transportation, *Report of the United States Housing Corporation*, vols. 1-2 (Washington, D.C.: Government Printing Office, 1919).

⁸United States Shipping Board, Emergency Fleet Corporation, Passenger Transportation and Housing Division, *Housing the Shipbuilders* (Phila., Pa., 1920), 1-2.

Despite such reservations, in 1924 the Queensboro Corporation adapted some of the theories of the Garden City movement to an urban setting and introduced block-plan houses in Jackson Heights, attached and semi-detached houses arranged in clusters and situated on landscaped blocks.

Page intentionally left blank

PLANNING AND DEVELOPMENT OF JACKSON HEIGHTS

The Queensboro Corporation⁹

During the years of economic expansion following World War I and the "boom" years of the 1920s, tracts of undeveloped land in the boroughs of the Bronx, Brooklyn, and Queens were made easily accessible to Manhattan by the newly-completed, rapid transit facilities. The limitations which had hampered housing reformers, legislators, and developers in Manhattan no longer held in the undeveloped areas of the other boroughs, where some developers owned hundreds of acres of unimproved farmland. One of these development firms was the Queensboro Corporation.

After its formation in 1909 by a number of prominent Queens businessmen and realtors, including Edward A. MacDougall (1874-1944) [Fig. 6] who eventually assumed total control of the Corporation, and with the strong financial backing of the Weightman family of Philadelphia who were among the wealthiest and largest landowners in that city, the Queensboro Corporation assembled, between 1910 and 1914, approximately 350 acres of undeveloped land in the Trains Meadow section of Newtown in Queens, about five miles east of midtown Manhattan [Fig. 7]. The Corporation's land was considered ideal for profitable development because of recent transportation improvements in Queens and the growth of the manufacturing district in Long Island City (where the Corporation relocated its headquarters from midtown Manhattan after the opening of the Queensboro Bridge).

The Queensboro Corporation was deeply involved in the extension of elevated rail service to the borough and in the municipal politics of the period. During the mayoralty campaign in 1917 between the incumbent Mayor John Purroy Mitchell and Judge John J. Hylan, Hylan charged that Mitchell, while he was President of the Board of Aldermen and therefore a voting member of the Board of Estimate and Apportionment, was also the legal representative of the Queensboro Corporation and he

...personally put through the Board of Estimate the extension of the Corona subway so as to tap the Queensboro Corporation's property. He negotiated with other members of the Board to vote for the extension which had been opposed because it lay through a section practically uninhabited. Mr. Mitchell coralled enough votes to pass the extension and then, to keep the record straight so far as the minutes of the Board of Estimate were concerned, cast his vote against the extension.¹⁰

Indeed, the Corporation's considerable political clout is evidenced by the five stations on or near the southern boundary of Queensboro's land. The syndicate proved to be successful not only in bringing

⁹For a more detailed history of the Queensboro Corporation and the development of Jackson Heights see Daniel Karatzas, *Jackson Heights: A Garden in the City* (New York: Jackson Heights Beautification Group, 1990).

¹⁰*New York Times*, Nov. 3, 1917, p. 4. According to Hylan, shortly after the vote Mitchell was sent to Europe by the Corporation to sell \$3,000,000 worth of its bonds for which he stood to gain a commission of \$90,000. Mitchell failed to sell the bonds but the Corporation did pay for all his expenses. Furthermore, Hylan contended that Mitchell controlled the Tax Commission and that "last year [1916] the tax impost on the Corporation was \$64,780; this year it is \$44,120. By a stroke of the pen Mr. Mitchell's tax board has made the Queensboro Corporation a gift of \$20,660 in taxes for the current year." Mitchell lost the 1917 election to Hylan.

the "subway to the cornfields" but also in the domain of promotion. In 1916, the Corporation began to publish the *Jackson Heights News*, a chronicle of local events which served as an advertising vehicle for Queensboro's developments and was primarily a promotional tool to lure prospective residents. The first broadcast of a radio commercial, aired on August 22, 1922, was one of four ten-minute advertisements for apartments in Jackson Heights.¹¹

Development History of Jackson Heights

The first few years of activity by the Queensboro Corporation concentrated on the construction of the infrastructure: grading the property; installing water, sewer, and electrical lines; and laying streets. In planning the streets through the property, the standard grid system used in Manhattan was adopted but the pitfall of the system -- the long east-west orientation of the blocks -- was avoided. At Jackson Heights, the long sides of the blocks are oriented on the north-south axis, which allows sunlight into both the front and rear of the buildings.

Initially, the Corporation intended to develop its property as a subdivision of concrete cottages, following a construction method proposed by Thomas A. Edison, but quickly abandoned this idea and began to sell its land in 100- by 100-foot parcels. The first speculative buildings in the district were the rowhouses, designed by Charles Peck and built in 1911 on 82nd and 83rd streets, just north of Roosevelt Avenue, by Charles E. Currier, president of the Jackson Heights Building Company. The rowhouses on 82nd Street have been demolished or altered for commercial purposes, but those on 83rd Street are still standing.¹² These two-story masonry buildings are examples of traditional rowhouse design and planning and indicate what the area might have looked like had the Corporation not shifted its efforts to apartment house construction [Fig. 8].

Queensboro was not directly involved in construction until 1913-14 when it erected a group of four five-story brick apartment houses, collectively known as Laurel Court, on the southeast corner of 82nd Street and Northern Boulevard near a stop on the then-existing trolley line to Manhattan [Fig. 9]. Designed by George Henry Wells, who became one of the Corporation's principal apartment building architects, Laurel Court is a group of four multiple dwellings built according to the requirements of the 1901 Tenement House Act, which specified minimum dimensions for courtyards and rear yards and a maximum lot coverage of seventy percent. Laurel Court was soon followed by Wells's Oban Court and Penrhyn Court (1914-15), Willow Court (1915), the Colonial Apartments (1915-16), and the Plymouth Apartments (1916), all of which were erected along 82nd Street, the main thoroughfare linking the trolley stop on Northern Boulevard and the elevated-line station on Roosevelt Avenue [Fig. 10]. Queensboro sought to capitalize on the need for housing for those commuting to work in the manufacturing concerns in Long Island City:

It was first thought that the majority of artisans [employed in Long Island City] would go back and forth to Manhattan, or else go to the older sections of Williamsburgh and Brooklyn. Up to the present time this has been the case, but last summer [in 1915] several new apartment houses

¹¹Queensboro paid \$100.00 for each of the four spots, broadcast by the new NBC station, WEAJ. See "Jackson Heights: A Neighborhood of Gardens," *Queens Tribune* 3, no. 28 (July 16-22, 1993), 42; Bruce Handy, "What Is It About August?," *New York Times Magazine*, August 1, 1993, p. 22; and Karatzas, 82.

¹²Eighty-second Street between Roosevelt and 37th Avenues was rezoned from residential to commercial in October, 1927. See *Real Estate Record & Guide* 21, no. 122 (Nov. 24, 1928), 43-44.

were erected at Jackson Heights by the Queensboro Corporation, and so successful were the enterprises that six new buildings are now under construction and will be ready for the summer renting season. But this movement is only in its infancy and the present demand is far in excess of the supply, as was witnessed with the ease with which tenants were obtained for the structures as soon as completed.¹³

As the 1910s progressed, the Corporation made some of its most important contributions to the planning, architecture, and development of the city by producing a new building type, the "garden apartment." With the Plymouth Apartments and Willow Court, Queensboro had proved that substantially reduced lot coverage (fifty-eight percent compared to the legal minimum of seventy percent) was a financially sound and profitable policy. Following this success, the Corporation began construction of Wells's Greystone Apartments in 1916, and, in 1917, announced plans for Linden Court, designed by Andrew Jackson Thomas, the second major architect to design apartment buildings for the corporation. With these two projects, Queensboro demonstrated the utility and profitability of whole-block designs featuring buildings with low lot coverage and incorporating a substantial amount of landscaped open space.

The new direction taken in Jackson Heights seems to have been at least partly influenced by similar work being done in Europe, and especially Germany, at about the same time. In 1914, members of the Corporation had traveled abroad to visit various housing developments and were said to have been particularly impressed by two projects in the Berlin suburb of Charlottenburg.¹⁴ Built between 1907 and 1909 to house civil servants, the projects were designed by Erich Kohn and Paul Mebes, the latter of whom became one of Germany's most influential architects between the two World Wars. Set in substantial open space, the contiguous "U"-shaped buildings have landscaped courtyards that alternately open to the north and south [Fig. 11].¹⁵

Queensboro pursued other innovations in the attempt to make its buildings desirable; it was among the first development firms in the city to make extensive use of the automatic push-button elevator in its low-rise apartments after the Building Code was changed in 1920 to permit them. At Linden Court, ground-level garages, a novelty at the time, were provided. In addition, beginning with Linden Court, Queensboro introduced a plan for cooperative ownership of apartments and converted existing rental units in Jackson Heights to cooperatives. In so doing, Queensboro established the legal precedent for such conversions, a move which has had a tremendous impact on the New York City real estate market in

¹³"Apartment House Trend in Queens," *Real Estate Record & Guide* 97 (Jan. 22, 1916), 127.

¹⁴John Taylor Boyd, Jr., "Garden Apartments in Cities: Part II," *Architectural Record* 48 (Aug., 1920), 122.

¹⁵Plunz, 138.

more recent years.¹⁶ The majority of the buildings which followed were sold under the Corporation's plan of cooperative ownership.

Subsequent to the construction of Linden Court, Queensboro initiated major projects each year to the designs of either George H. Wells or Andrew J. Thomas: Hampton Court (Wells, begun 1919); Elm Court, Hawthorne Court, and Laburnum Court (Wells, begun 1921); the Chateau and Hayes Court (Thomas, begun 1922) and Cambridge Court (Wells, begun 1922); the Towers (Thomas, begun 1923); and Ivy Court, Cedar Court, and the Spanish Gardens (Thomas, begun 1924). These yearly building campaigns were encouraged by the passage of state legislation in 1920 and 1923 which allowed ten-year real estate tax exemptions on new construction.¹⁷ Moreover, in 1922, the state legislature amended the State Insurance Code to allow insurance companies to invest in housing projects.¹⁸ The Metropolitan Life Insurance Company was a strong lobbyist for this legislation and also one of the important financial backers of Queensboro's efforts at Jackson Heights. In 1921, it had loaned over \$1,400,000 to the Corporation for the construction of Elm, Hawthorne, and Laburnum Courts.¹⁹ By the following year, Metropolitan Life had loaned Queensboro almost \$8,000,000.²⁰

In 1924, the Queensboro Corporation redirected its efforts to building groups of single-family and convertible two-family houses; the firm's president, E.A. MacDougall, is said to have made this change in policy in response to the requests of the young veterans of World War I who wanted their own homes. At about the same time, with the completion of Ivy Court (1924), the Corporation responded to those who could not afford to buy their own apartments and began to rent the units rather than sell them as cooperatives. Another reason for the new policies was that Queensboro was being faced with resistance to the expensive prices of the units in its garden apartment complexes, which had become progressively more elaborate and more costly to build. Indeed, one project designed by Ernest Flagg, for the entire block between 35th and 37th avenues, 77th and 78th streets, was halted after the foundations were laid. It was over a decade before that block was developed with Berkeley Hall and Berkeley Gardens.²¹

¹⁶*New York Times*, Nov. 14, 1920, p. 3; Dec. 1, 1920, p. 31. The precedent-setting case involved a tenant who held a lease from Queensboro but refused to vacate the apartment at the expiration of his lease and refused to buy the apartment. The decision in the case was rendered by Justice Edgar F. Hazelton who upheld the legality of a tenant-formed corporation to purchase the building it occupies and confirmed its right to possession of the building. Conversions under eviction plans were the norm until the 1980s; more recent conversions are non-eviction plans which allow tenants with renewable rent-stabilized leases to remain indefinitely without buying into the cooperative.

¹⁷The law pertained to buildings completed between April, 1920, and April, 1924, but commenced before April, 1922. This legislation was renewed in 1923 for housing completed between 1920 and 1926 but commenced before 1924.

¹⁸Plunz, 150-151.

¹⁹*New York Times*, Sept. 25, 1921, sect. 9, p. 1.

²⁰*New York Times*, Aug. 20, 1922, sect. 8, p. 1. When Metropolitan Life began to build its own housing projects in 1922, it hired Queensboro's architect, Andrew J. Thomas, to design its three initial complexes, which are located in Sunnyside, Astoria, and Woodside, all in Queens.

²¹Karatzas, 62-66.

In the 1920s Queensboro also started selling large parcels of its undeveloped land to outside developers with the agreement that Queensboro would act as managing agent for the new buildings for the first ten years; there were also restrictions entered into the deeds governing use, materials, height, placement of fire escapes, entrance and egress over the properties, signage, awnings, and heights of ornamental hedges. Thus, Queensboro continued to exert considerable control over the development and maintenance of the area.

From the earliest years, Queensboro attempted to create a complete community, not just a residential enclave, and it actively encouraged the growth of religious, educational, commercial, social, and recreational life for the residents of the area. In 1920, architectural critic John Taylor Boyd, Jr., who was among the first to write about the development of the garden apartment, wrote about Jackson Heights:

It is no less than a small city. In the process [of developing the area] a community center with a building is already established, churches are organized, community recreations, such as playgrounds, golf links, gardens, are in operation on the corporation's land, stores are provided for, and other needs of a little city are planned for as they will be required. This, truly, is city planning.²²

This community foundation was enhanced and elaborated upon over the next thirty years.

During the Depression years of the 1930s Queensboro found it was no longer profitable to continue to build small houses as it had done in the late 1920s. In this changing economy, the Corporation turned to the development of six-story elevator apartment houses intended for rental, increasingly the most common building type erected throughout the city in those years. The reason for the shift was given by MacDougall in a *New York Times* interview:

Building lots which were purchased twenty years ago for two hundred dollars or less now bring from twenty to thirty thousand dollars each. These increases have put an end to the possibility of more small dwellings in Jackson Heights so far as residential property is concerned, and that type of land is now reserved for apartment houses of not less than six stories.²³

Seemingly undaunted by the financial climate of the times, Queensboro pushed ahead with a number of building campaigns in 1931. One of the most ambitious called for the construction of twelve- to fifteen-story buildings to cover three city blocks near the new station of the I.R.T. subway at the intersection of Broadway and 74th Street (outside the boundaries of the historic district). Rosario Candela, a prolific Manhattan apartment house architect, was commissioned to design the project. A second project was a mixed-use building -- which was to include a 500-room hotel, forty stores, and a taxi and bus terminal -- to occupy the blockfront on the north side of 37th Avenue between 82nd and 83rd Streets. Though neither of these projects were built, more than a dozen large apartment complexes were

²²Boyd, 131.

²³*New York Times*, Jan. 5, 1930, sect. 12, p. 4. MacDougall's reasoning seems somewhat ingenuous as Queensboro had acquired its property some twenty years earlier. Clearly the Corporation was seeking to capitalize on contemporary real estate trends.

completed during the 1930s, filling in some of the sites at the avenue ends of the garden apartment complexes and open spaces such as the golf course (Dunolly Gardens).

Little development took place within the area of the historic district during the wartime years of the 1940s. It was only with the end of the decade and the first few years of the 1950s that construction resumed on the remaining undeveloped parcels of land. Due to limited building activity since then, the area of the district retains much of the character it achieved at that time. The Corporation had become the insurance broker and managing agent for many of the apartment houses and continued in that role until its failure in 1989. During the 1980s, many of the rental buildings within the district were converted to cooperatives, recalling the plan begun by Queensboro sixty years before.

The Cooperative Plan of Ownership²⁴

Cooperatively-owned apartment buildings existed in various European cities from the early nineteenth century. New York, however, was much slower to accept the idea of apartment living and it was not until late in the nineteenth century that apartments became acceptable for the middle and upper income groups. By this time, the advent of spacious, well-designed apartments, together with the rising cost of land for individual homes in the city and a shortage of capable domestic help, brought a wealthier clientele to apartment life.

The concept of cooperative ownership became one way of making this new type of living arrangement more attractive to an affluent clientele. The idea of being able to choose one's neighbors and thus achieve a certain degree of exclusivity was appealing. In addition, cooperative ownership inspired better architecture than generally had been seen in New York apartments, since the owner-shareholders would be living in the buildings and not just investing in them in hopes of a large profit. The cooperative idea quickly became accepted for middle-class housing as well. Developers were attracted to the idea because they could realize a quick return on their investments.

Early New York Ventures

The first cooperative apartment houses in New York were isolated projects built in the 1880s, including the Knickerbocker (1882, demolished), located on Fifth Avenue at 28th Street, and the Gramercy Park Apartments (1883, in the Gramercy Park Historic District). At the same time, Hubert, Pirsson & Company, architects and builders, were developing a similar type of apartment building under the name of the Hubert Home Clubs. These include No. 121 Madison Avenue and the Chelsea Apartments (now the Chelsea Hotel, a designated New York City Landmark) at 222 West 23rd Street, both built in 1883. However, a contemporary cooperative venture by the same firm, the Central Park Apartments (a/k/a Spanish Flats), once located on Seventh Avenue between West 58th and 59th streets, was a financial disaster because the tenant-owners did not have full control of the building. This failure effectively halted the further development of cooperative apartments until the twentieth century.

The earliest cooperatives built in New York in this century were a group of duplex apartment houses on West 67th Street, designed to meet the specific needs of artists, with double-height, rear-facing studios lit by northern light and attached living quarters. Commissioned by a group of artists, the first, No. 27 West 67th Street, was built in 1901-03 (Sturgis & Simonson). The venture proved so successful that another group of artist-investors built the Atelier Building at 33 West 67th Street, on a similar plan,

²⁴Information concerning the development of cooperative ownership in New York City is found in LPC, *Gainsborough Studios Designation Report*, report prepared by Virginia Kurshan (New York, 1988).

and this was followed by other similar projects on the same block, thus establishing a secluded and prosperous artists' colony.

Like the artists' studios, many early cooperatives were built by organizations or specific communities of people. Such was the case in 1916 when immigrant families from Finland, a country where there was a long cooperative tradition in many fields, joined together to address the housing shortage in the Sunset Park section of Brooklyn by building or converting existing buildings into the city's first not-for-profit cooperatives. The first, Alku I (the Finnish word for "beginning"), was soon followed by others in the area, all built by the Sunset Home Association.²⁵

As early as 1907, cooperative apartments were declared "a prominent feature of the realty situation in New York."²⁶ Two years later in the *New York Times* it was reported that fifteen to twenty cooperative apartments had been erected in New York during the previous few years.²⁷ However, it was at Jackson Heights where cooperative ownership was first successfully introduced to a wide audience of middle-class New Yorkers, making the concept a standard feature of the city's real estate market.

*The Jackson Heights Plan of Cooperative Ownership*²⁸

When the Queensboro Corporation began to develop Jackson Heights, the first apartment buildings were rentals. It was not until 1919, ten years after the commencement of development, that Queensboro introduced a plan of cooperative ownership for its newly-built apartments and also converted existing rentals to this plan.

Under the Jackson Heights plan, the Queensboro Corporation sold the apartment buildings it had erected to individual corporations composed of tenant-shareholders. The tenant corporation owned full equity of its building and property, while Queensboro managed the building for the first ten years. A buyer did not actually purchase the apartment outright, but rather purchased shares of stock in the corporation and received a proprietary lease to the apartment. Instead of paying the entire equity price of the apartment prior to occupancy, the buyer made an initial payment of ten to twenty percent of the total equity price, which included the underlying mortgage, and paid the balance monthly on the same basis as rent over a period of eight to twenty years. Half of each monthly payment was applied to the purchase price and the balance was applied to maintenance of the property.

The Queensboro Corporation emphasized the cooperative nature of its garden apartments in all its promotional literature, stressing that investment in Jackson Heights ensured safety of the principal

²⁵Each shareholder held a lease; if the shareholder moved, he sold the shares back to the cooperative society for the price paid. National Register of Historic Places, *Sunset Park Historic District*, U.S. Department of the Interior, Heritage, Conservation and Recreation Services (form prepared by Andrew Dolkart, 1988).

²⁶*Real Estate Record and Guide*, Sept. 28, 1907, 474.

²⁷Payson McL. Merrill, "Recent Developments of Cooperative Apartments," *New York Times*, April 25, 1909, sect. 7, p. 2.

²⁸The information concerning the Queensboro Corporation's plan for cooperative ownership is from a promotional brochure "Investment Features of Cooperative Apartment Ownership at Jackson Heights" (New York, 1925).

invested and the marketability of the investment; i.e., the resale of the stock. Potential buyers were assured of the high quality of the design of Queensboro's buildings, of the superior standards of the workmanship and material, and of the corporation's comprehensive plan for maintenance and future development. Queensboro also argued that cooperative ownership enhanced the permanent, stable nature of the neighborhood against rapidly changing conditions in the real estate market and allowed owners to select neighbors who were socially desirable and financially responsible. Cooperative ownership of an apartment in one of the garden complexes both amplified the residents' common interest and deepened the sense of community which contributed to the distinctive character of the area. By 1925, nearly \$20,000,000 had been invested in Jackson Heights, and its cooperative garden apartments, if built on both sides of Fifth Avenue in Manhattan, would extend from 42nd Street to 62nd Street.²⁹

²⁹Ibid.

THE ARCHITECTURE OF JACKSON HEIGHTS

The buildings in the Jackson Heights Historic District were erected between 1911 and the present, the great majority of them dating from the four decades between the mid-1910s and the early 1950s. The unusual character of Jackson Heights owes much to its pioneering development as a community of block-plan garden apartments and house groups. These buildings are complemented by later end-block and mid-block apartment buildings, as well as by commercial, civic, and institutional buildings which were built over a wide span of years.

The architecture of Jackson Heights is characterized by an overall simplicity of design, reflecting the movement away from the extensive use of ornament popular during the late nineteenth century. Generally, simple facade treatments are combined with such picturesque elements as loggias and belvederes (on the apartment buildings), entrance porches, gables, tile and slate roofs with various profiles, and decorative brickwork. The facades of the buildings in the district are largely executed in brick, and are rendered in historically-based styles, ranging from Georgian, Tudor, Gothic, Italian Renaissance, and Spanish Romanesque in the 1910s, '20s, and '30s, to Art Deco, Moderne, and International Style in the 1930s, '40s, and '50s. As a rule, the architectural expression of the buildings in Jackson Heights tends toward the conservative.

The names of architectural styles by which buildings are identified in this report are generalizations based on references to historic sources. The architects who designed what are called "neo-Tudor" or "neo-Romanesque" buildings did not intend to produce archeologically correct recreations of historic styles. Instead, they attempted to evoke the flavor, or suggestion, of English, Spanish or Italian buildings, and the resulting work is best described as a free adaptation, often combining elements drawn from more than one source.

Early Rowhouses

The earliest surviving buildings in the Jackson Heights Historic District are the two-story-and-basement rowhouses on the west side of 83rd Street near Roosevelt Avenue, built in 1911 to designs by Charles Peck. Predating any of Queensboro's planning innovations, they are characteristic of rowhouse development in New York prior to World War I -- a row of contiguous buildings with modest neo-classical detail. These houses are an illustration of what the area might have looked like had Queensboro not shifted its efforts to apartment building construction.

The Garden Apartment: George H. Wells and Andrew J. Thomas

Among the most significant contributions to the historic district were the block-plan garden apartment complexes designed between 1917 and the late 1920s by architect George H. Wells and his contemporary, Andrew J. Thomas.

George H. Wells

The first apartment buildings erected by the Queensboro Corporation were a series of buildings on 82nd Street erected in 1914, 1915, and 1916 to designs by George Henry Wells. Little is known about Wells's training or early work. Born in Michigan in 1866, he lived in Illinois as a young man. He was in New York City by the late 1890s, for in 1899 he was working as supervisor of construction at the New York Custom House. James Knox Taylor, the Supervising Architect of the U.S. Treasury Department, introduced Wells to Cass Gilbert, the architect of the Custom House (and Taylor's former partner), who had opened a New York office that year. Gilbert hired Wells away from the Federal

government in 1900, and Wells stayed with him for fifteen years, working on many of Gilbert's prominent projects.³⁰ Wells was still in Gilbert's office in 1914 when he designed Laurel Court, his first project in Jackson Heights. The following year he formed his own practice, and over the next decade designed apartment houses for the Queensboro Corporation. From 1899 until 1935 Wells lived in Mt. Vernon, New York, except for the period of 1917-18 during which he lived in Elmhurst, the neighborhood just south of Jackson Heights. His New York firm had closed by 1935, and the following year he was no longer a resident of Mt. Vernon. Wells would have been about seventy years old, and presumably either retired or died in that year. No record of any independent work outside of his Jackson Heights apartment buildings has been discovered. That he also had experience in the design of single-family residences, however, is suggested by a 1929 *New York Times* article about fireproof houses, which quoted him extensively.³¹

Although Wells designed half a dozen of the pioneering block-plan garden apartment complexes in Jackson Heights, he began his career there with five walk-up apartment building groups, all built on 82nd Street, between the corner of Northern Boulevard, where there was a streetcar stop, and Roosevelt Avenue where the elevated train is located: Laurel Court (1913-14), Oban Court and Penrhyn Court (1914-15), Willow Court (1915), Colonial Apartments (1915-16), and Plymouth Apartments (1916).

Wells's early Jackson Heights projects all suggest groups or rows of buildings -- the germ of what would become the large, block-long complexes of the next decade. Four and five stories high, with long street frontages, these early apartment buildings are relatively conventional in design. While their plans advance toward the garden apartment type, with progressively greater lot areas left open for light and air (in particular, the Plymouth Apartments and Willow Court), their facades, like those of most walk-up apartments of their time, are faced in brick with stone trim, either cast stone or limestone, and given a simple ornamental treatment. In all but the Colonial Apartments the decorative scheme reflects a simplified, rectilinear version of classical styles, and shows the strong influence of a design trend in Edwardian England that was in turn influenced by Parisian classicism. The Plymouth Apartments, for instance, bears a striking resemblance to a six-story apartment building at 12 Hyde Park Place in London built in 1902-03, just a decade earlier, to designs by Frank T. Verity [Fig. 12].³² The London building has been described as having "a smoothly machined Champs-Elysees style of *maisons-de-luxe* which eliminated the traditional and clumsy giant order in favour of big windows, neat stonework and flowing iron balconies."³³ Though somewhat modest by comparison, the Plymouth Apartments shares with its English predecessor a modified pavilion plan, large windows, rusticated banding, and a projecting cornice topped by a parapet. The metal fire escapes on Wells's buildings are only partially suggestive of the iron balconies of Verity's building, but the projecting central entry porch of the London building is clearly echoed by a similar projecting entrance porch at the Plymouth Apartments [Fig. 13]. Such projecting porches became a hallmark of Wells's subsequent work in Jackson Heights. In the building entries of this report, these early buildings by Wells are characterized as "Edwardian" in style, in recognition of the English influence on their design.

³⁰Sharon Lee Irish, "Cass Gilbert's Career in New York, 1899-1905," Ph.D. diss., Northwestern University, 1985, 632.

³¹"Fireproof Homes for All Dwellers," *New York Times*, Sept. 1, 1929, sect. 11, p. 4.

³²This building is illustrated in Alastair Service, *Edwardian Architecture and its Origins* (Wallop, Hampshire, Great Britain: The Architectural Press Limited, 1975), 449.

³³*Ibid.*

At the Colonial Apartments, Wells took a major step toward what would become his preferred architectural scheme for the facades of block-plan garden apartments. The Colonial Apartments suggest six identical buildings, each with a separate entryway, which display a rhythm of repeated architectural elements that visually defines the blockfront. In ornamental style, as well, the Colonial Apartments mark a change in approach: Wells abandoned the Edwardian fashion in favor of the neo-Georgian, one of several picturesque, historically-based styles that would come to characterize most of the buildings of Jackson Heights over the following decades.

The Colonial Apartments are clad in red brick with white stone trim -- including keystones, panels with ornamental swags, and parapets with balustrades -- and are designed to suggest the eighteenth-century architectural fashion either of England and its North American colonies in the time of the King Georges (hence the term neo-Georgian), or of the slightly later period when the liberated colonies had united under a federal government (hence neo-Federal). At the Colonial Apartments, Wells's characteristic projecting entryway takes the form of a classical round-arched doorway within a portico. In the building entries of this report, buildings of this style are uniformly referred to as "neo-Georgian," to avoid attempting distinctions between Federal and Georgian.

The plan and layout of the Plymouth Apartments and Willow Court were an advance over the Corporation's earlier work. The amount of the lot covered by these projects is radically reduced and their construction marks an important point in the evolution of Queensboro's development intentions and design policy [Figs. 14 and 15].

The builders [Queensboro], realizing their opportunity to establish an apartment section which would be a model for the whole borough of Queens, which would attract residents from all other boroughs, decided to give apartment houses so in excess of the requirements of the Tenement House Law that nothing in the city would equal them in this respect. The result is that the new Jackson Heights houses [the Plymouth Apartments and Willow Court], instead of occupying 70 per cent. of the lot area like most houses as is allowed by law, occupy only 58 per cent. of the lot area, leaving an additional 12 per cent. or a total of 42 per cent. for light and air courts. To do that in Manhattan and in some parts of Brooklyn and the Bronx would bankrupt builders....³⁴

The garden-apartment block plan evolved further in 1916 when the Corporation commissioned Wells to design fourteen five-story apartment buildings, a row of seven on each side of 80th Street between 35th and 37th Avenues. At first named the Garden Apartments and later the Greystone Apartments (after the gray face brick), the group (built 1917-18) creates a unified, harmonious streetscape of two facing blockfronts. Each row of the Greystones consists of contiguous buildings covering about thirty-eight percent of their roughly sixty-three by 100-foot lots. The "T"-shaped buildings join to form "U"-shaped courts which open onto the unbuilt rear portions of the lots; the rear area is treated as undivided property and landscaped as continuous garden space behind each blockfront. The rear elevations are faced with beige-colored brick, the light tone of which reflects natural light into the courtyards. The Greystones were planned with only two apartments per floor; each apartment was two rooms wide and two rooms deep and had a rear extension into the garden containing a kitchen and maids' quarters, a layout derived from the nineteenth-century rowhouse. Each room opens onto either the tree-lined street or the landscaped rear garden.

³⁴"Queens A Coming Apartment Center," *Real Estate Record & Guide* 97 (Mar. 25, 1916), 471.

At the Greystones, Wells took the rhythmic facade repetition of his earlier work at the Colonial Apartments still further, creating a series of almost identical brick and stone-faced buildings with alternating entrance and roof details. The architectural expression emphasizes the cohesiveness of the facing street facades. In place of the Georgian or Federal styling of the Colonial Apartments, Wells turned to a different English source for the Greystones, the Tudor, which would become popular in future Queensboro buildings. Details characteristic of that style include the continuous crenelated parapets, the projecting tower-like entrance bays, and especially, the projecting Tudor-arched entry porches with ogival leaded-glass transoms, panels, and finials [Fig 16].

In November of 1917, while the Greystones were nearing completion, MacDougal announced that plans were being prepared for an entire block of garden apartments in Jackson Heights.³⁵ The complex, designed by Andrew J. Thomas, is Linden Court, located between Roosevelt and 37th avenues, 84th and 85th streets. Actual construction did not begin until the middle of 1919, delayed undoubtedly because of World War I and difficulty in procuring the necessary financing.³⁶

Andrew J. Thomas

Andrew Jackson Thomas (1875-1965) established himself as a practitioner in the field of planned housing with his innovative work for the Queensboro Corporation. Now widely regarded as a seminal figure in the history of that field, Thomas is credited as the developer of the "garden apartment," in which he perfected the system of "block ventilation" and an apartment plan that served as a model for later state and federal housing programs.

Born in lower Manhattan, the son of a diamond broker, Thomas was orphaned at the age of thirteen and began a series of jobs that took him from the gold fields of the Yukon to collecting rents in the slum tenements along Columbus Avenue. It was while working as a timekeeper for a building contractor that Thomas began to study construction plans which prompted his self-taught architectural career.

Some of Thomas's first apartment houses were done while he was on the Board of Design of the U.S. Shipping Board's Emergency Fleet Housing Corporation during World War I. Thomas also worked for the City and Suburban Homes Company. After the war, he found work with the Queensboro Corporation, for which he developed his version of the "garden apartment" which was to serve as the model for all his future projects.

About 1922, the Metropolitan Life Insurance Company, which provided much of the mortgage money for the Queensboro Corporation, hired Thomas as the architect for its first housing projects, all of which were built in Queens. While Thomas was working for Queensboro in Jackson Heights and for Metropolitan Life in Sunnyside, Astoria, and Woodside, Frederick Ackerman and Henry Wright, with whom Thomas had worked during the war, were beginning their famous housing development, "Sunnyside Gardens," with Clarence Stein. When Stein and Wright created Radburn in New Jersey, Thomas was commissioned to design the only apartment house in that model community.

³⁵*New York Times*, Nov. 11, 1917, p. 10.

³⁶*New York Times*, May 25, 1919, sect. 9, p. 20. Financing was eventually provided by the Title Guarantee & Trust Company for approximately \$500,000 which, along with the value of the land, represented an investment of \$900,000.

Thomas's work caught the attention and interest of John D. Rockefeller, Jr., who hired him to design the award-winning Dunbar Apartments (1926-28) in Central Harlem (the first major nonprofit cooperative complex built specifically for African-Americans) and the Thomas Apartments (1928) on the Grand Concourse in the Bronx. During his long career, Thomas worked tirelessly to improve housing conditions for the working poor and built a number of model projects in New York, Bayonne, New Jersey, and Brooklyn. It testifies to the quality of his work and the esteem in which it was held by his contemporaries that New York City's first publicly-funded housing project, the "First Houses" on East 3rd Street and Avenue A in Manhattan, follows the typical Thomas block plan. Later in his career, Thomas served as the New York State Architect, designing a number of hospitals including Coney Island Hospital in Brooklyn.³⁷

For Linden Court, his first work in Jackson Heights, Thomas designed two identical blockfronts of detached buildings framing the interior of the block which is occupied by a large garden [Fig. 17]. Thomas opened up the street wall by grouping the five structures on each blockfront into paired units separated by open passages -- actually driveways -- which provide access into the block's interior. The pair at the center of each blockfront is the widest, and the buildings successively decrease in width toward each end. The Mediterranean-inspired ambience of Linden Court is an interesting contrast to the Tudor and Georgian references in other complexes. Round-arched entryways with heavy wooden doors, rope moldings and ornamental stone shields, iron balconies, and Spanish-tile roofs are varied in their placement on the buildings, and all suggest the Romanesque and Renaissance architecture of Italy and Spain [Fig. 18]. Partly due to the influence of the Pan-American Exhibition of 1912 in California, this Mediterranean imagery became popular in American architecture during the 1910s and 1920s. There are a great many examples of this style in Jackson Heights, and because the preponderance of ornament in many of them seems to be of Romanesque inspiration, these buildings are identified in the building entries of this report as being "neo-Romanesque."

Linden Court proved to be an architectural and financial success. The *New York Times* reported extensively on the plan and design of the new complex:

An important feature of the planning of the new houses is the fact that they are to be of the detached and semi-detached type. This innovation in apartment house planning will permit free circulation of light and air between each house and cross ventilation in the rooms. In addition, however, each suite is laid out to run through from the front to the rear of the building. The rear outlook will be over an interior garden, similar to those already provided for in the improvement of other Jackson Heights garden blocks. In order that this 'garden apartment' plan be carried out to the fullest extent, the Queensboro Corporation has decided upon the erection of the new houses on plots having not less than 83' nor more than 120' frontage. These larger units do away with the necessity of constructing the deep houses in which tenants have been compelled to

³⁷Biographical information is from Thomas's obituary, *New York Times*, July 27, 1965, p. 33. For a fuller treatment of Thomas's work and its place in the history of planned housing, see Plunz, 124 ff and 164 ff.

live, which lack the light and air that is obtained in this new type of house.³⁸

The *Times* went on further to quote the architect of the complex, Andrew J. Thomas:

...the basic thought of these model apartments, and they are indeed model apartments, is the perfect room arrangement of suites and a maximum of light and ventilation. They are...provided with spacious side courts which...serve as automobile driveways as well....In general, the planning has been arranged to allow for elaborate gardening, walk, and general recreation facilities.³⁹

Architectural critic John Taylor Boyd, Jr., also commented on Linden Court:

It is evident that the block has been designed as a whole in a simple, but comprehensive, and highly coordinated architectural design.... [The garden's] benefits are apparent when it is remembered that the streets are the only playground of New York children, including the children of the rich; even the luxurious Park Avenue apartment houses make a poor showing in this respect....It is evident that from the point of view of convenience, comfort, cheerfulness, even of beauty, this group closely approaches an ideal type of housing....As architecture goes, it could hardly be improved upon.⁴⁰

Boyd wrote further that:

In viewing this fine collection of buildings, with the splendid long garden in the interior, one cannot help feeling that here, considered from all points of view, is the highest achievement in the garden apartment that has been reached so far. It clearly places Mr. Thomas as the creator of the first true garden apartment group on a city block that has been designed as a whole....⁴¹

Among the other innovative features of the complex, besides the provision of ground-level garages, was the introduction of the enclosed loggia, "creating not only an aspect of a country house in an apartment house, but the comfort as well."⁴² The concept of the enclosed loggia later developed into the corner solarium, a feature found in many Art Deco apartment houses.

³⁸"Queensboro Corporation Commences the Erection of Sixteen New Apartment Houses in Jackson Heights," *New York Times*, May 25, 1919, sect. 9, p. 20.

³⁹Ibid.

⁴⁰Boyd, "Garden Apartments in Cities: Part I," (July 1920), 60-62.

⁴¹Boyd, Part II, 134.

⁴²"Queensboro Corporation Commences....," *New York Times*, p. 20.

Taking his cue from Thomas's crystallization of the block-plan garden apartment complex at Linden Court, Wells went on to design the next five garden-apartment blocks: Hampton Court in 1919-21; Hawthorne Court, Elm Court, and Laburnum Court in 1921-22; and Cambridge Court in 1922. In all five of these complexes, the architectural design, using red brick and stone trim, draws on Georgian sources. Hampton, Hawthorne, and Cambridge are each comprised of two long blockfronts of shallow buildings framing an interior garden. Elm and Laburnum occupy smaller assemblages and do not define full blocks. Unlike the buildings at Linden Court, the buildings in each of these later complexes are identical (with the exception of Cambridge Court) and attached, rather than semi-detached, forming unbroken blockfronts. Characteristic of Wells's work, the design of each complex is visually defined by a rhythm of repeated architectural elements. At Hawthorne Court and Elm Court, Wells used his signature projecting entryways [Fig. 19]; at Hampton Court the rhythmic repetition is created along the 79th Street side of the complex by angled, projecting window bays (the buildings on 78th Street have a different facade treatment). At Laburnum Court, the configuration is entirely different, with "H"-shaped buildings forming recessed street-front garden courts as well as rear gardens [Fig. 20].

Cambridge Court, the last of Wells's Jackson Heights block-plan garden apartments, has the most complex configuration of all his projects. Composed of seven attached buildings on each side of the block, each row has projecting buildings at the ends and center, creating the effect of a long pavilion. While the projecting buildings have four full stories capped by a cornice and balustraded parapet, the fourth story of each of the recessed buildings is hidden behind a steeply sloping mansard roof [Fig. 21].

Thomas followed Wells with six garden apartment complexes built between 1922 and 1926. Three of these were block-long complexes: the Chateau, the Towers, and Spanish Gardens; the other three were planned with landscaped courtyards and located at the ends of blocks: Hayes Court, Ivy Court, and Cedar Court.

The Chateau (1922) and the Towers (1923-25) are among the grandest of the Jackson Heights garden apartment complexes, each comprising almost a full block and including the end of each block facing 34th Avenue. Like Thomas's earlier Linden Court, each complex is broken up by intervening passages into the interior garden, making the garden visible from the street. At 34th Avenue, however, the gardens of both complexes extend to the lot line. At the time of construction of the Chateau and the Towers, 34th Avenue was landscaped with a wide median strip; thus, originally the two long gardens of the complexes visually connected across the landscaped avenue to form a two-block long interior greenway; some of that effect survives despite the loss of the median strip landscaping [Fig. 22].

The individual buildings at the Chateau and the Towers, like those at Linden Court, are distinguished by variations in massing and detail in what are otherwise similar designs. Of the four buildings in each blockfront of the Towers, the two in the center are designed as symmetrical, Mediterranean-style palaces, with round-arched entrances and overhanging cornices, while those at the end are asymmetrically massed with high corner towers. The towers frame both the long street groupings and the garden area at the short avenue frontage. Described in a contemporary account as being inspired by "Central Italy at its best period,"⁴³ the Towers, with its cornices, arched entrances, and tile roofs, continues the Mediterranean style introduced at Linden Court.

The arrangement of the buildings of the Chateau group is somewhat different, with each blockfront composed of six buildings which are slightly asymmetrical in their massing. The end buildings are taller and more complex in their ornament than the others, serving as terminating elements to each

⁴³From *Queens Borough Magazine* (Oct., 1923); cited in Karatzas, 62.

row. Thomas drew upon French inspiration for the ornamental style of the Chateau -- the French word for "castle" -- incorporating mansard roofs at the upper story of each building and diaperwork brick patterning in the end buildings.

At Spanish Gardens (1924-26), Thomas tried yet another approach to the organization of buildings around a block by including front gardens, as Wells had done at Laburnum Court, in addition to the characteristic central inner garden. Each blockfront of Spanish Gardens is composed of three identical and very large buildings, each roughly twice the size of the individual buildings at the other garden complexes. The recessed front court of each building has a projecting porch entry, similar to those in most of Wells's designs. Decorative ornament, particularly the tile roofs and entry details, though not as elaborate as that of either the Towers or the Chateau, is nevertheless suggestive of Mediterranean sources, living up to the complex's name and complementing the architectural expression of Linden Court on the adjacent block to the east [Fig. 23].

Thomas's last three complexes of this period -- Hayes Court, Ivy Court, and Cedar Court -- are smaller, occupying end-block sites. Hayes Court and Ivy Court both center on inner courts which are entered from the side streets via barrel-vaulted archways and from the avenue through wide openings; Cedar Court is "C"-shaped and opens toward the avenue. In style they follow the pattern of Thomas's other work: Hayes Court (named for Hayes Avenue, the former name of 34th Avenue, on which it fronts), with its mansard roof and brick diaperwork, is similar to the Chateau; while Ivy Court and Cedar Court, occupying opposite ends of one block, continue the tile roofs, towers and Mediterranean ornament of the Towers.

An essential element of Queensboro's comprehensive, coordinated block plan was landscape design. After the streets had been laid out, each block was framed by a continuous grass strip that ran on all four sides between the street curb and the sidewalk. This grass enframing, planted with trees and shrubbery, was a typical feature of suburban development in New York City in the late nineteenth and early twentieth centuries.⁴⁴ The buildings were set back from the building line behind an area of lawn and plantings expanding the block's frame of grass, shrubbery, and trees. Behind the buildings, occupying the entire center of the block, were the expansive interior gardens which were quite literally the centerpiece of the Queensboro Corporation's block-plan concept [Fig. 24]. These gardens were as carefully planned as the buildings bordering them and their designs can be traced to the landscape traditions of the Italian Renaissance, the French Beaux-Arts, and the English Romantic movement. The landscape architecture of the blocks contributes to the character of the Jackson Heights Historic District as much as the architectural style of the buildings [Fig. 25].

The garden apartments of Jackson Heights attracted the interest not only of American architects, city planners, and housing experts during the 1920s, but also of international practitioners. Delegates and representatives of housing ministries from countries that included Canada, Mexico, Japan, New Zealand, Great Britain, Greece, Sweden, Finland, Germany, the Netherlands, and France visited the

⁴⁴The practice of planting trees along the residential streets of the city can be documented back to the early 1790s. In 1806, the city stated that it encouraged the planting of street trees because they were "ornamental" to the city and conducive to the health of the inhabitants. The curbside "mall" or grass strip lined with trees seems to have originated with Olmsted & Vaux's design for the exterior boundaries of Central Park in 1858. This feature was further popularized by the City Beautiful Movement in the 1890s and the Garden City Movement in the early decades of this century.

area.⁴⁵ The French were particularly interested in the work being done at Jackson Heights. After a visit to New York, architect M. Antoine returned to France with maps, plans, and other literature concerning Jackson Heights, which proved to be influential in the development by the Society of Cooperative Enterprises in Paris of at least four groups of buildings containing about one thousand apartments [Fig. 26].⁴⁶

The Block-Plan House

Between 1924 and 1929, the Queensboro Corporation turned from garden apartments to attached and semi-detached single-family (and "convertible" two-family) houses in Jackson Heights, the plans of which reflected some of the concepts embodied in the "Garden City" movement, a new approach to planning suburban regions. Based on English precedents from the beginning of the century, the ideas of this movement had been implemented in this country in such developments as Forest Hills Gardens and in government-sponsored housing of the World War I era. Just as Queensboro had pioneered with its block-plan garden apartment complexes in Jackson Heights, so too the new block-plan houses were designed along innovative lines, joining historically-based styles with such up-to-date conveniences as open layouts, modern appointments, and planning amenities appropriate for the automobile age.

The majority of the houses in the Jackson Heights Historic District were designed by Robert Tappan, and by Charles F. and Daniel E. McAvoy, between 1924 and 1927, followed in the next two years by the work of several other architects. Most are located in the eastern section of the historic district, between 84th and 88th streets.

The architects of houses in Jackson Heights adapted the Garden City model, which was conceived for suburban residential enclaves laid out on winding roads, to an urban street grid plan, using features of the whole-block garden apartment plans by Wells and Thomas. The blocks of houses are, like the garden apartments, treated as single design units; the rows of attached houses are set back from the building line and broken at regular intervals by broad, open spaces into discrete groups of between four and eight houses each; the semi-detached houses are grouped into pairs. Garages are included either under the rear of the houses, allowing a block-long greensward at the interior of the block, or a paved alley is laid down the center of the block and lined with garages designed in the styles of the houses. The pairs of houses often have attached garages reached from the street by short driveways. Jackson Heights is one of the earliest communities in the city planned to accommodate the automobile.

The houses in Jackson Heights are designed in revival styles which draw largely from such English sources as Georgian and Tudor architecture, but also incorporate a variety of elements from other sources, such as Spanish-tile roofs. The blockfronts form picturesque ensembles distinguished by varied materials and alternating roof treatments, creating patterns of architectural detail within and among the groups. In the building entries of this report, all these houses are identified as "Anglo-American Garden Homes."

C.F. & D.E. McAvoy

The first rowhouses developed by Queensboro were designed by C.F. & D.E. McAvoy. The brothers Charles F. and Daniel E. McAvoy specialized in home-building from early in the century until

⁴⁵*New York Times*, May 3, 1925, p. 2; July 30, 1922, sect. 8, p. 1.

⁴⁶*New York Times*, Mar. 25, 1923, sect. 10, p. 1.

the onset of the Depression. Their particular concern was the development of housing in Queens, and their work can be found in Forest Hills and Jackson Heights, as well as in Nassau County. Like Wells and Thomas in the sphere of garden apartments, the McAvoy's were innovators in the planning and building of housing. As early as 1917 Daniel McAvoy (1886/87-1968)⁴⁷ began developing prefabricated units. Though his proposals met with "the derision of much of the building industry" at first, the so-called McAvoy plan was adopted in Miami in 1926 to meet a local housing shortage. McAvoy's interest in Queens led to his serving as president of the Queensboro Plaza Association in the 1920s, at which time he promoted the notion that Queensboro Plaza should become the city's major transportation center. After 1929, Daniel McAvoy turned to "advising the government on housing matters." As Secretary of the Home Mortgage Advisory Board, he was active in finding alternative financing mechanisms to avert home foreclosures during the Depression.

The first group of McAvoy houses, built in 1924, consists of twenty single-family homes occupying most of the blockfront on the east side of 87th Street between Roosevelt and 37th avenues. Promoted by Queensboro as "English Convertible Garden Homes" these houses could, at the discretion of the owners, be "converted" into two-family residences. In their site plan and layout, they show the influence of the Garden City Movement and the spirit of experimentation in house design around World War I. The houses are divided into four distinct freestanding groups with five attached houses in each; the groups are designed as cohesive units. The resulting streetscape breaks with the continuous street wall typical of nineteenth-century rowhouse development, and allows natural ventilation and light into the block.

In this first group, the McAvoy's alternated the house designs within each cluster, and conceived each cluster to look like a single unit, massing them with recessed sections and projecting wings to suggest the form of a pavilion. The four clusters vary in turn. Certain architectural elements provide variation among the houses, including prominent gables, roof profiles, and dormers, while other features provide continuity, such as the brick facing, roof tiles, and classical detailing. Basement garages are provided at the rear below each house. Access to the garages is provided by a common driveway, entered and exited at the ends of the blockfront, which separates the houses from a continuous landscaped berm. This overall scheme is based on Thomas's block-plan for the garden apartments at Linden Court. Furthermore, the plan provides sightlines from the street into the interior of the block, creating a sense of openness and space that distinguishes Garden City-inspired rowhouse planning from earlier, standard rowhouse blocks. In the following year, the McAvoy's designed a similar group of eighteen houses further north on 87th Street [Fig. 27]. The McAvoy's third group (1926) [Fig. 28], located on 87th Street opposite the architects' second group, is composed of seven double-houses, signalling a departure from the longer rows. Each pair is designed as a unit, and the facade designs of these units alternate down the block. The detailing is Tudor in inspiration.

Robert Tappan

Robert Tappan (1883/84-1961), like the McAvoy's, also did much of his work in Queens, including Forest Hills where he lived for many years.⁴⁸ Like Daniel McAvoy, he was known as a housing innovator, both in planning and in structural matters. He advocated prefabrication for small houses, and particularly promoted the use of steel-frame construction, until then associated primarily with

⁴⁷Daniel McAvoy obituary, *New York Times*, Mar. 3, 1968, p. 88.

⁴⁸Robert Tappan obituary, *New York Times*, May 30, 1961, p. 17.

skyscraper building.⁴⁹ From the early years of his career he was interested in the problem of affordable housing, and won first prize in 1917 for a "Competition for a house to cost not to exceed \$5,500 [sic]," sponsored by the *American Architect*.⁵⁰

Tappan's first group of houses in Jackson Heights is the row on the east side of 87th Street between 34th and 35th avenues, built in 1925. It is composed of sixteen brick houses with pitched shingled roofs, grouped into clusters of varying sizes. Each outer cluster of six houses suggests a pavilion in its massing, with projecting end units having front-facing gable ends. The inner clusters have houses with shared gable ends. This approach to design creates the effect of a larger single entity. The simple detailing -- brick quoins, round-arched entryways, dormers, and tall chimneys with chimneypots -- is drawn largely from English, and particularly Georgian, sources. The row of houses on the other side of the block, facing 88th Street, was constructed in the following year to designs by C.L. Varrone [Fig. 29]. This group mimics the slightly earlier Tappan design, but with the addition of Spanish-tile roofs to otherwise English-inspired ornament. Together, the two groups form a complete block, with interior automobile mews and symmetrically placed garages incorporating the design elements of the houses. The result is a planned block typical of Queensboro's best efforts.

Tappan's second row was built in 1925-26 on the west side of 88th Street between 35th and 37th Avenues, back-to-back with the McAvoy's second row of 1925. Here the houses are organized as three groups, with four central rowhouses flanked by two sets of eight rowhouses. Their ornament, drawn largely from Georgian sources, includes round-arched front doors, fanlights, and peaked slate roofs. Behind the houses in the center of the block are sets of paired garages, one garage per house, designed in the same material and style as the houses. The common driveway is shared by the Tappan houses on 88th Street and the McAvoy houses on 87th Street.

In 1926-27 Tappan had the opportunity to design a through-the-block complex of houses on 86th and 87th Streets between 34th and 35th Avenues [Fig. 30]. As in the McAvoy houses on 87th Street, Tappan turned away from long rows to groups of semi-detached double-houses, ten houses on each blockfront arranged as five pairs. In its scale and massing, each double-house suggests a larger, freestanding single-family house, though each has two entrances and two attached garages, one at each side. The detailing of the houses is largely Georgian-inspired, and by varying the placement of chimneys and entrance porches, Tappan created lively diversity within the group. The interior of the block is given over to a large green area of individual gardens.

Three other architects were responsible for rows of houses within the district at the end of the 1920s: Benjamin Dreisler, Jr., Pierce L. Kiesewetter, and James D. Junge. In 1926, Dreisler designed twenty-three houses grouped into clusters, occupying the blockfronts of 78th and 79th Streets, between 37th and Roosevelt Avenues. The architectural details are loosely Georgian-inspired, yet include contrasting Spanish-tiled mansard roofs. The houses frame an interior berm, and common driveways lead to garages under the houses.

The Plymouth Houses, designed in 1928 by Pierce Kiesewetter, occupy the blockfronts of 84th and 83rd streets between 34th and 35th avenues. The fifteen houses on each street are divided into three clusters of five houses each. Massing and detail draw on English sources, primarily Tudor, evoked by the use of half-timbering [Fig. 31].

⁴⁹Robert Tappan, "A house built like a skyscraper," *American Architect* 132 (Nov. 5, 1928), 619-622.

⁵⁰*American Architect* 3, no. 2165 (June 20, 1917), plate.

In 1929 James D. Junge designed two matching clusters of five houses each on 83rd Street, each cluster arranged with alternating house designs. The style of these houses draws on English sources, with gables, porches, and roofs mixing cedar shingles with Spanish tiles. These were the last such group erected within the district until 1951, when T. Atcuri designed a row of five attached houses on 84th Street, featuring red brick facing, slate roofs, and some permastone siding. The most recent group of attached houses constructed in the district was built on 86th Street in the late 1980s.

Later Apartment Buildings

Late 1920s - 1940s

When economic constraints at the onset of the Depression led the Queensboro Corporation to turn from houses back to apartments, the garden apartment model apparently had become impractical. The planning of apartment blocks in the meantime had evolved to large, airy six-story buildings with a variety of inner courtyards and outer lightcourts providing light, air and greenery. It was to this new model, developed for New York neighborhoods in the 1920s, that Queensboro now turned: large individual apartment houses on courtyard plans, instead of rows of interrelated smaller buildings on block plans. Many of these buildings were constructed throughout the district, especially along 35th Avenue where undeveloped lots remained at the ends of the long street blocks containing earlier garden apartments.

The bulk, height and form of these later apartment houses reflect the building codes and tax legislation of the period which granted incentives for the building of rental apartments. Building codes required fireproof construction for apartment houses taller than six stories, an expense that tended to limit building height to five or six stories. Buildings occupying more of their lot produced more rental income than buildings occupying less; requirements for light and air resulted in lightcourts, often along the street fronts of these buildings. Nevertheless, these buildings reflect the evolution of the apartment house type and represent the next step in the history of Jackson Heights development.

Many of the architects who worked in Jackson Heights during this period were active throughout the city. Within the area of the district, the most active of all the firms during this period was Cohn Brothers, which contributed nearly one dozen apartment buildings. Seelig & Finkelstein, Joshua Tabatchnik, Kavy & Kavovitt, and E. Adelson were each responsible for several apartment buildings, while others, such as Hyman I. Feldman and Julius Fishkin, are credited with a few apiece.

Like Wells and Thomas, the architects of these buildings drew on a variety of historical sources for their designs. The chief difference between the earlier and later applications of the historically-based styles is that the larger individual structures of the later period, in contrast to the earlier garden apartment complexes of related smaller buildings, evoke these stylistic references using more boldly-scaled ornamental features applied to relatively austere facades. As in the earlier work, the majority of the designs were based on the architecture either of England or of the Mediterranean world. Red brick buildings with white classically-inspired trim reflect the architecture of the Georgian period in England, or else the early Federal period (the American adaptation of the Georgian) in this country. Ogival arches and label lintels, on the other hand, are drawn from the earlier Tudor period. The Mediterranean sources are Italy and Spain, particularly from the Romanesque and Renaissance periods. Round-arched doorways, elaborately carved lintels and bandcourses, picturesque towers and loggias, and Spanish-tile roofs all show Mediterranean inspiration [Fig. 32]. In the building entries of this report, apartment buildings are labeled "neo-Georgian" if the ornament by and large is drawn from English or early American architecture, or "neo-Romanesque" if drawn from Mediterranean sources.

A typical neo-Georgian design from this period is the Georgian Hall Apartments, occupying the entire block end of 37th Avenue between 83rd and 84th Streets, and built in 1930-31 to designs by E. Adelson. The symbolism of the style is reflected in its name, as is the case in many of these 1930s apartments; others in the district include Georgian Gardens and Colonial Arms, as well as names more obliquely suggestive of the Colonial and early Federal periods including Mt. Vernon (after Washington's estate), Jefferson Hall, and The Litchfield (presumably after the colonial town in Connecticut).

Georgian Hall has a monumental facade design appropriate to its scale [Fig. 33]. This facade stretches along 37th Avenue and is articulated by two giant Georgian-style temple fronts in brick with stone trim. Georgian-inspired ornamental elements include a balustraded parapet, stone swags, and urns. Light and air are provided by recessed entrance courtyards, one each on 83rd Street and 84th Street. Since it fronts on commercial 37th Avenue, Georgian Hall has stores; in this case, the storefronts are located in a one-story projection designed with balustraded parapets and decorative stone urns. Similar arrangements of lightcourts and multi-story temple fronts in brick and stone characterize most of the neo-Georgian buildings of this era in the district.

Representative neo-Romanesque designs from this period can be found at Oak Hall West and East (1930-31), which are identical back-to-back buildings designed by Cohn Brothers, and located on 83rd and 84th streets, between 35th and 37th avenues. Like Georgian Hall and all the other apartment buildings from this period, the Oak Hall buildings use a boldly-scaled, symmetrical design to articulate their long facades. Each building is divided into two sections by a very large courtyard entrance fronted by an ornamental brick gateway -- complete with stone lions and a wrought-iron canopy -- leading to a projecting arched entrance portico. Tower-like forms, round-arched windows, corbelling, balconies, gargoyles, loggias, and a variety of patterned brickwork, all deriving from Romanesque sources, are used to enliven these long brick facades.

Less common in the historic district are buildings from the inter-war period which have designs reflecting more modernistic trends, such as the Art Deco or Moderne styles. The two most notable examples are Maple Court (1930, Ricca & Ungaleider) on 81st Street, and Dunolly Gardens (1939), a characteristic garden apartment complex designed by Andrew Thomas. Maple Court is a modest example of Art Deco design, articulated with decorative brick piers and geometric cast-stone trim. Dunolly Gardens is much more ambitious, representing Thomas's block-plan updated to a late 1930s sensibility. The architectural style of this complex is defined by the stark geometry of horizontal and vertical brick banding and sharply angled window bays. The contrast with the Mediterranean styling of Thomas's early 1920s projects is striking [Fig. 34].

Post-World War II

Following World War II, buildings were constructed on previously undeveloped lots within the area of the district. These buildings are generally large, six-story structures planned with lightcourts and courtyards which divide the mass into smaller parts. Their siting, height, massing, scale, and materials harmonize with the earlier fabric of the area. The facades of these buildings are spare in their decorative treatment, following post-war taste and the increasing influence of the International Style, and the designs may make only subtle allusions to established architectural styles. In the building entries of this report, most of these buildings are referred to as "neo-Georgian (post-World War II)" or "Moderne (post-World War II)."

There are a few examples of residential buildings designed in the International Style within the boundaries of the historic district. The most notable is the Roosevelt Terrace Apartments, built in 1952-54 and designed by Philip Birnbaum, among the most productive of New York's post-war architects.

While Roosevelt Terrace on first sight seems out of scale and character with the surrounding neighborhood, it can be seen as a continuation of the block planning that characterized the earlier garden apartments in the neighborhood. Like its predecessors, the complex is comprised of a group of interrelated buildings arranged on a block plan, taking up most of the block (as well as a portion of the adjacent block). Characteristic of the International Style, however, is the siting of the buildings on the diagonal, abandoning the traditional concept of a block as an area subdivided into rectilinear building lots. Consequently, there is no boundary between the inner block and the outer street wall, and the common central garden typical of the 1920s garden apartments is supplanted by open space surrounding the buildings and park areas in unbuilt segments of the block. Garages are located under the gardens.

Institutional and Public Buildings

The institutional and public buildings of Jackson Heights, which include schools, churches and synagogues, a library, and a post office, enhance the sense of a self-sufficient town within the larger city. The Queensboro Corporation, and especially Edward MacDougall, played an active role in their development.

Until the early 1920s there were no houses of worship in Jackson Heights, rather congregations held services in storefronts or at the Community Casino (no longer extant). The Community United Methodist Church received encouragement and aid from the Corporation, which initially provided a storefront to serve as the church's first home,⁵¹ and subsequently donated the land for its current building.⁵² F.P. Platt's design for the church, built in 1920-23, draws on Tudor inspiration [Fig. 35]. Robert Tappan, architect of many houses in the historic district, produced a Modern Gothic design in his plans for the St. Mark's Episcopal Church, built in 1927. The St. Joan of Arc R.C. Church complex has a more complicated history. The St. Joan of Arc parish was established by the Brooklyn diocese and it was thought at the time that Jackson Heights might become the location of a new Catholic diocese of Queens. In anticipation of this event, the first design of St. Joan of Arc was modeled after the great French Gothic cathedrals. However, the diocese was never approved and only the basement level of this ambitious first plan had been completed by the late 1920s. The church was finally completed in 1951 to a design derived from Italian Romanesque sources by local architect, W.A. Schlusing [Fig. 36]. The complex also includes a convent, a school, and a rectory. Another house of worship within the historic district is the First Church of Christ, Scientist, whose mid-1920s neo-Georgian design by Arnold Brunner was completed only at the basement; the structure, with its striking limestone facade in the Moderne style, was finished in the early 1950s to designs by C. Faulkner. The churches in the district are joined by two buildings which serve the Jewish congregants of Jackson Heights: the Jewish Center of Jackson Heights, an International Style synagogue built in 1959-60 to designs by Bloch & Hesse (with an addition by J. Stein in 1968-69); and the Young Israel of Jackson Heights which occupies a converted commercial building on 37th Avenue (Jack Fein, 1951; later altered).

The public buildings of Jackson Heights, designed in the 1920s, '30s and '40s, followed the lead of the neighborhood's apartment houses in their architectural design. These structures are all located on or near the main commercial street of 37th Avenue. P.S. 69, the neighborhood's public elementary school, is representative of the work of New York public school architect, C.B.J. Snyder, Superintendent of Buildings for the Board of Education from 1891 until 1923. Typical of his work from the 1920s, it

⁵¹"Founding of Churches," *Jackson Heights News* 18, no. 16 (Aug. 24, 1934), 1.

⁵²*Jackson Heights News* 7, no. 12 (June 8, 1923), 4.

is neo-Tudor in style, harmonizing with much of the commercial and residential architecture elsewhere in the area. The neo-Georgian style of the post office (Benjamin C. Flourney, 1936-37, with later additions) [Fig. 37] also complements many of the surrounding apartment houses. The Queens Borough Public Library branch (S. Keller, 1949-52) is an example of the International Style.

Commercial Buildings

The Jackson Heights Historic District represents one of the first areas in the city in which the commercial thoroughfares were designed to complement and integrate with the residential buildings by using the same architectural styles or by incorporating features of adjoining residential buildings into their design. Within the boundaries of the historic district are two major commercial thoroughfares: the spine of 37th Avenue running the length of the district, and the intersecting block of 82nd Street between 37th and Roosevelt avenues.

In the city's original 1916 zoning, only 37th Avenue, Roosevelt Avenue, and Northern Boulevard were zoned for commercial purposes. The 82nd Street block, originally residential, was rezoned for commercial use in 1927,⁵³ probably because of its location between two commercial avenues and its proximity to the elevated train station. It had been an important street from the time of initial development in Jackson Heights, beginning with the early apartment buildings erected by Queensboro near the streetcar stop on Northern Boulevard. An earlier commercial strip had existed on Northern Boulevard (outside the historic district), an old road running straight through Queens and out past the city line; the boulevard, however, proved less important than 37th Avenue as commercial uses moved closer to the elevated train line along Roosevelt Avenue. The train station is located above the avenue at the southern end of 82nd Street; staircases which lead to the station from the sidewalks on each side of the street are a strong presence at that end of the block.

The cluster of neo-Tudor commercial buildings at the intersection of 82nd Street and 37th Avenue originally occupied three of the four corners. Several neo-Tudor structures stretch down the block toward Roosevelt Avenue. The first of the neo-Tudor buildings to be erected was the commercial block at the southeast corner of the intersection, a one-story stone-faced building with an angled tower at the corner. Designed by Seelig & Finkelstein and built in 1921-22, it stood as the sole Tudor structure at the intersection until a building campaign by the Queensboro Corporation on the west side of 82nd Street solidified the character of the block.

In 1928 Queensboro erected, on the southwest corner of the intersection, a three-story headquarters building designed by Morrell Smith. The long facades are remarkably picturesque in their massing, with projecting gable ends, pitched slate roofs, brick chimneys, half-timbering, and ornamental rams' heads [Fig. 38]. In the same year, directly adjoining its headquarters to the south along 82nd Street, the firm built another long two-story commercial building, to designs by Robert Tappan. The building's name, "English Gables," is appropriate to its neo-Tudor style. Stretching 240 feet down 82nd Street, its facade has seven projecting gables, a continuous pitched slate roof, chimneys, half-timbering, and projecting wood oriels, all continuing the effect of Queensboro's headquarters, and with it defining the appearance of the street. This effect was continued by other structures built on the block between 1928 and 1931.

In the 1930s two buildings were added to the collection of neo-Tudor commercial buildings on 82nd Street. In 1935 and 1938-39 a commercial cluster known as "English Gables II" was built to the

⁵³*Real Estate Record & Guide*, Nov. 24, 1928, pp. 43-44.

designs of Simon B. Zelnik on the east side of 82nd Street. Containing stores and the Colony Theater, the two-story neo-Tudor building features triangular pediments with oriel windows, bas-relief terra-cotta panels, and a slate roof. The one-story building which stood at the northeast corner of 82nd Street and 37th Avenue, erected in 1937 and designed by J.H. Barry, had storefronts rising to half-timbered Tudor gables and a small corner tower (it was demolished in the late 1980s).

Altogether, the "English Gables" mode defines most of the 82nd Street streetscape, clearly identifying this block as a special place within Jackson Heights. With its cohesive architectural imagery, the block bears a striking similarity to commercial blocks near train stations in small suburban towns throughout the Northeast. In the 1980s, 82nd Street was pinpointed as a Business Improvement District to make it more attractive to shoppers and thus enhance its commercial viability. In conjunction with these efforts the sidewalks were widened and repaved, the street was narrowed, and bishop's Crook lightposts were installed along its length.

Although 37th Avenue had originally been planned for commercial development, by and large it developed later than the commercial block of 82nd Street, for the most part in the late 1930s and 1940s. Its commercial buildings are mostly one- and two-story groups of the kind often called "taxpayers"; these buildings all have stores on the avenue and the corner storefronts generally wrap around to the side streets, where additional storefronts also may be found. There are several apartment houses fronting on 37th Avenue which were designed to have continuous storefronts along the avenue frontage, and corner storefronts in those structures generally extend to the side streets, as well.

The earliest commercial building on 37th Avenue within the historic district was designed by George Wells for the Queensboro Corporation in 1920. It is located at the southwest corner of 37th Avenue and 83rd Street, adjacent to the neo-Tudor structure from 1921-22 at the intersection of 82nd Street. While signage obscures much of the building's avenue facade, the original brick facade with a Spanish-tiled eave is still evident along 83rd Street.

A number of examples of commercial architecture on 37th Avenue reflect the traditional styles of the surrounding apartment buildings. Georgian Hall, an apartment building of 1930-31 at 83rd Street, has, as described above, a one-story storefront projection along 37th Avenue which continues the building's neo-Georgian style. A freestanding group of 1937, by Lenz & Berger, also employs neo-Georgian details. Andrew Thomas designed a new office for the Queensboro Corporation in 1947, also in the neo-Georgian mode. Two 37th Avenue buildings draw on the neo-Tudor designs of 82nd Street, including one of 1940 by G. Salemi, and another of 1941 by Cohn Brothers.

Many of the avenue's commercial structures, however, are designed in the Moderne style, and were produced by a number of architects including Oscar I. Silverstone, Boris Dorfman, Shampan & Shampan, and Hanover & Morgenstein. Though they vary in detail, all of these Moderne commercial blocks with storefronts are one- and two-story buildings faced in brick and cast stone and featuring such modernistic details as curved or chamfered corners, long horizontal stone or metallic bands, stepped parapets, and patterned brickwork. Many originally had colored glass transoms.

Most of the storefronts within the historic district have been altered and large signs, fixed canopies, and exterior roll-down gates often obscure original features of the facades of the commercial buildings. Nevertheless, there is a substantial amount of historic storefront fabric which survives, particularly among the storefronts which are located in apartment buildings fronting onto 37th Avenue. Most of the buildings retain at least one storefront where evidence of the original configuration -- the arrangement of the bulkheads, show windows, signbands, and doors -- survives, even though the fabric may be changed.

Recent Developments

In the 1980s the area of the historic district saw the demolition of some of its original buildings. A number of private houses on 86th Street between 35th and 37th Avenues were razed; the new attached houses erected on the sites of the demolished houses, though complying with the then-existing zoning codes, exhibit few of the elements that distinguished the buildings they replaced. The neo-Tudor commercial blockfront on the north side of 37th Avenue between 82nd and 83rd streets was demolished; a new office building is currently (1993) under construction on that site. A new south wing for P.S. 69 is currently under construction. All in all, there has been relatively little new development within the district during the past few decades. Jackson Heights is remarkable not only for its innovative planning and attractive architecture, but also for the extent to which it remains faithful to the vision of its planners and architects.

CONCLUSION

The Jackson Heights Historic District exhibits a variety of experimental and innovative planning and design concepts that flowered in the beginning of this century. In Jackson Heights, various solutions to the chronic housing problems in the city, addressed and expressed in bricks and mortar, proved to be both economically and socially successful. Many of the ideas explored in Jackson Heights are now standard for middle-class housing. The area of the historic district comprises one of the earliest New York neighborhoods in which new building types -- the garden apartment house and the garden home -- were integrated with commercial, institutional, recreational and transportation facilities to create an alternative for middle-class residents to the then typical urban residential neighborhood. Jackson Heights has a strongly defined sense of place because of its overall design, planning, and integration of open space, as well as its high degree of intactness. After eighty years, the area remains one of the city's most vibrant and livable communities from which much can be learned by present-day architects and planners.

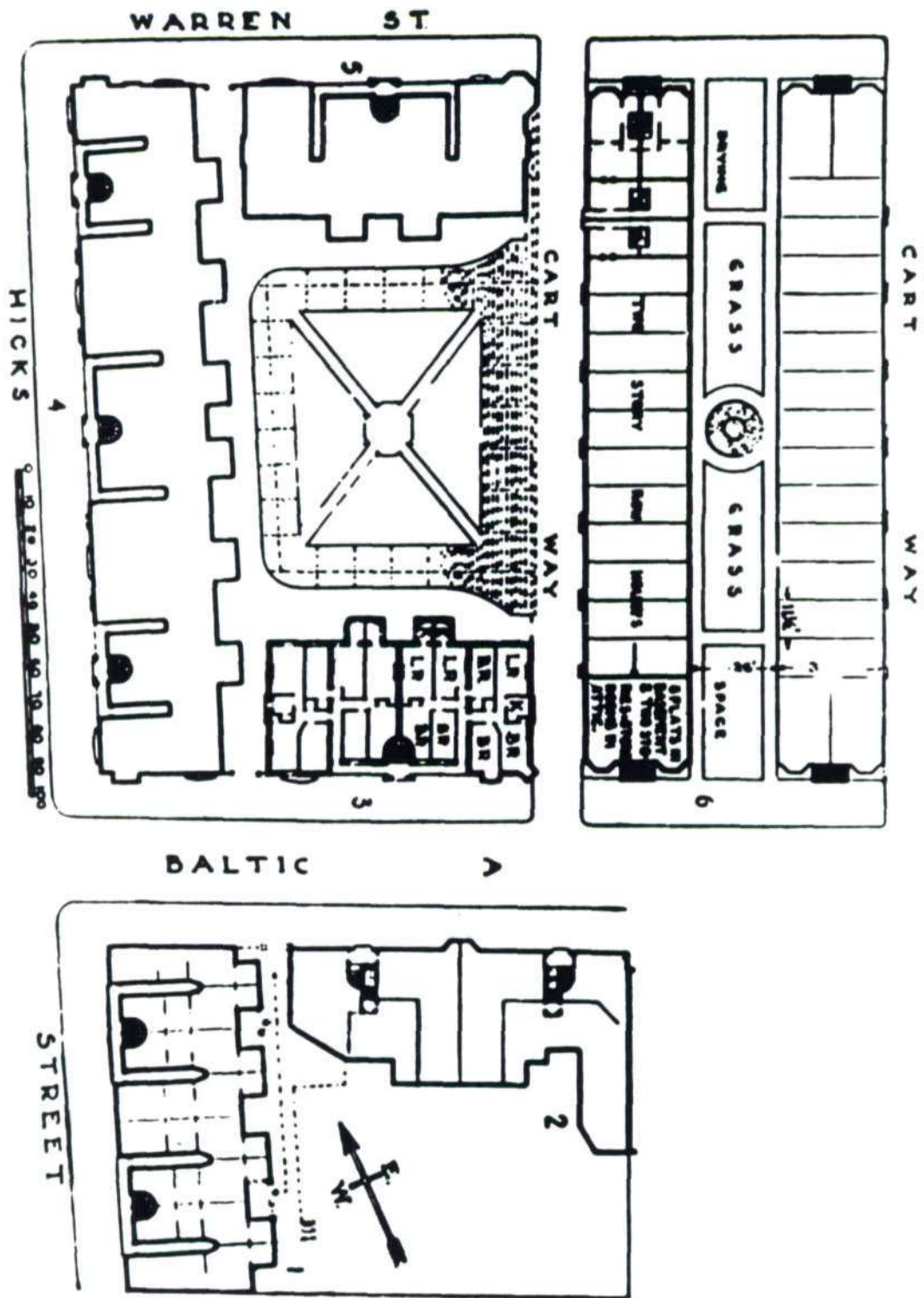

Fig. 1. Plan of the Home and Tower Buildings, 1876-79.

Source: Plunz, *A History of Housing in New York City*.

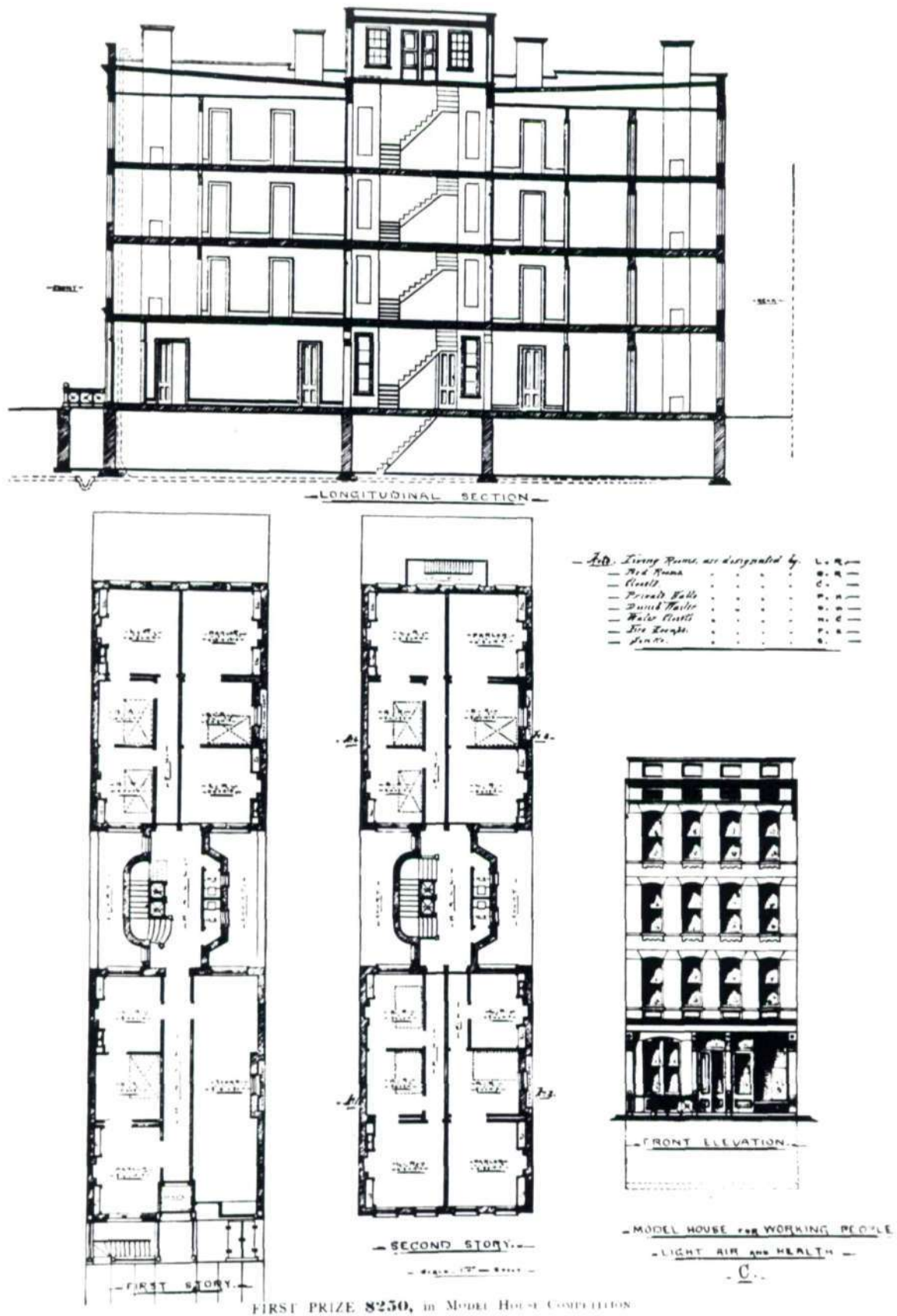
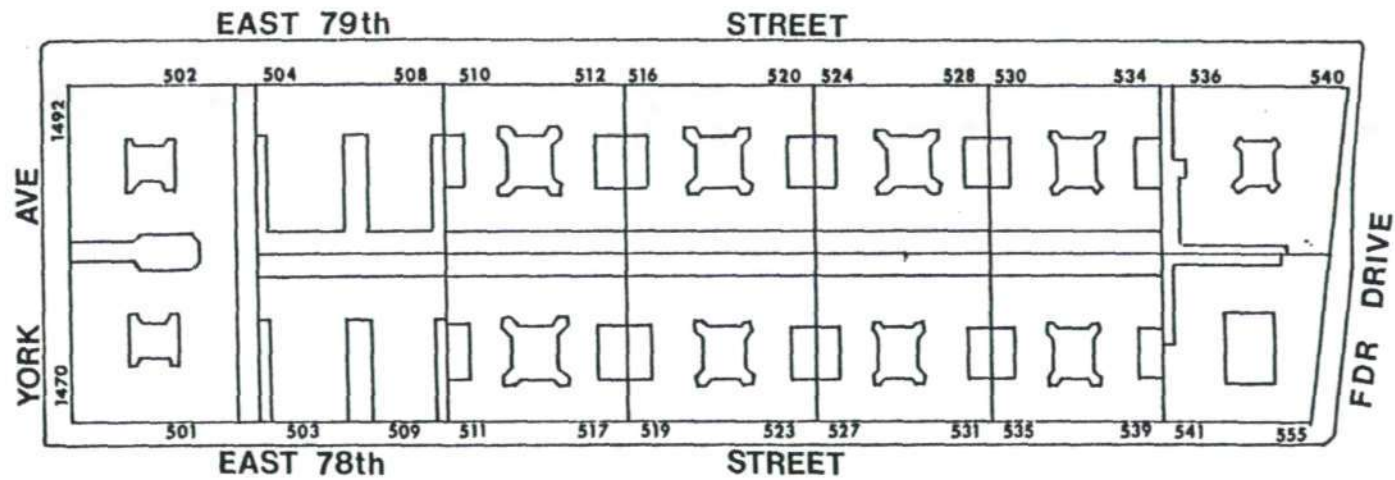

Fig. 2. "Dumbbell" plan by James E. Ware.

Source: Plunz, *A History of Housing in New York City*.

CITY AND SUBURBAN HOMES COMPANY
AVENUE A (YORK AVENUE) ESTATE



LANDMARKS PRESERVATION COMMISSION

DESIGNATED - APRIL 24, 1990

Fig. 3. Plan of the City and Suburban Homes Company, Avenue A (York Avenue) Estate.

Source: LPC files.



SEVEN-FAMILY ROW HOUSES

Scale 0 5 10 15 20 25 Feet

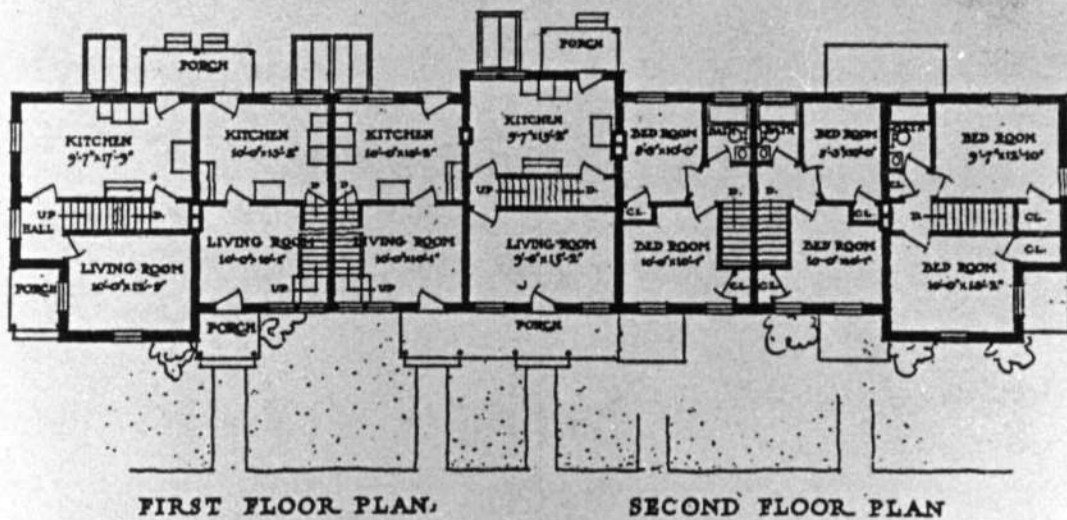

YORKSHIP VILLAGE CAMDEN NJ
 UNITED STATES SHIPPING BOARD
 EMERGENCY FLEET CORPORATION
 ELECTUS D LITCHFIELD RETAINED ARCHITECT NEW YORK

Fig. 4. Yorkship Village, Camden, N.J. (Electus D. Litchfield, c. 1918)

Source: U.S. Shipping Board, Emergency Fleet Corp. records. Photo, LPC files.



FOUR-FAMILY HOUSE

Scale 0 5 10 15 20 Feet

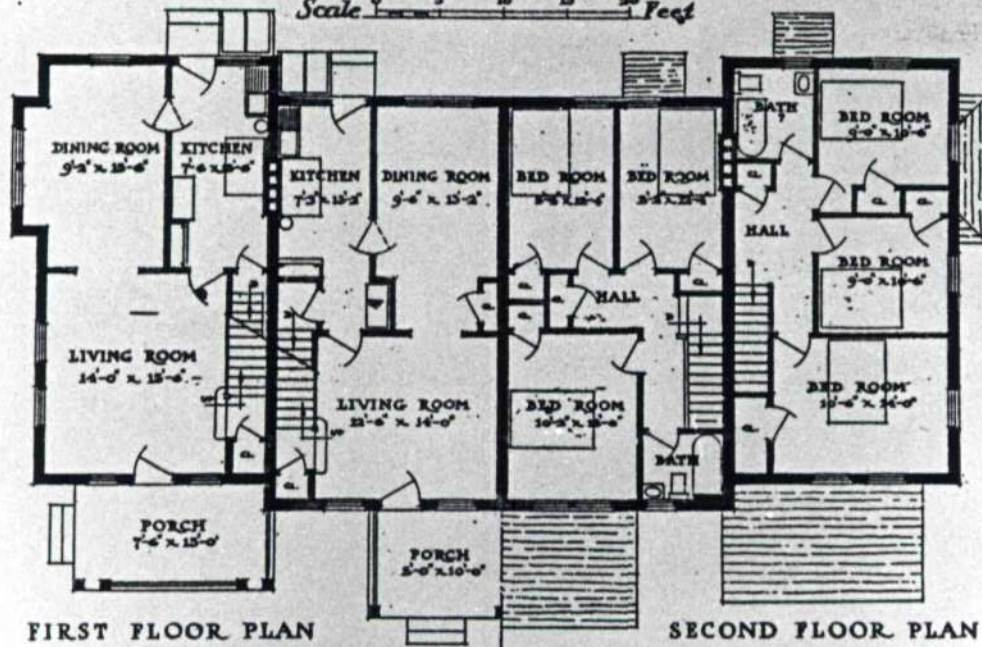

UNION PARK GARDENS WILMINGTON DEL
 UNITED STATES SHIPPING BOARD
 EMERGENCY FLEET CORPORATION
 BALLINGER & PERROT RETAINED ARCHITECTS PHILA PA

Fig. 5. Union Park Gardens, Wilmington, Del. (Ballinger & Perrot, c. 1918).

Source: U.S. Shipping Board, Emergency Fleet Corp. records. Photo, LPC files.



Fig. 6. Edward A. McDougall (1874-1924), c. 1928.

Source: Collection of Thomas Langan



Fig. 7. View northwest from Elmhurst across the Queensboro Corp.'s undeveloped land, c. 1909. Source: Collection of Thomas Langan



Fig. 8. Rowhouses (Charles Peck, 1911), east side of 83rd Street, between Roosevelt and 37th avenues.

Photo credit: Warren Shaw



Fig. 9. Laurel Court (George H. Wells, 1913-14) in c. 1916.

Source: *Real Estate Record & Guide* 97 (Jan. 22, 1916), 127.



Fig. 10. Willow Court (George H. Wells, 1915) in c. 1916.

Source: *Real Estate Record & Guide* 97 (Jan. 22, 1916), 127.

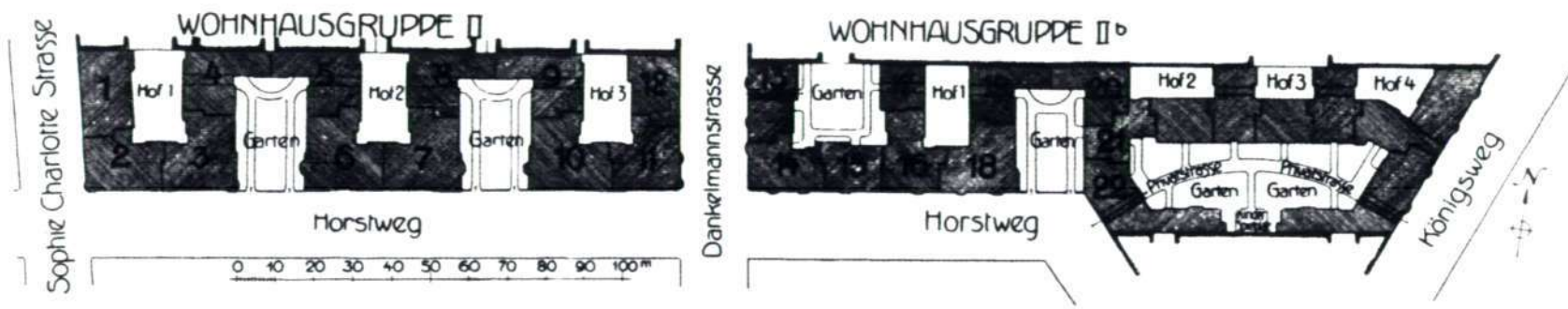

Fig. 11. Berlin Civil Servants Dwelling Association, plan of Charlottenburg II Project (1907-09).

Source: Plunz, *A History of Housing in New York City*.

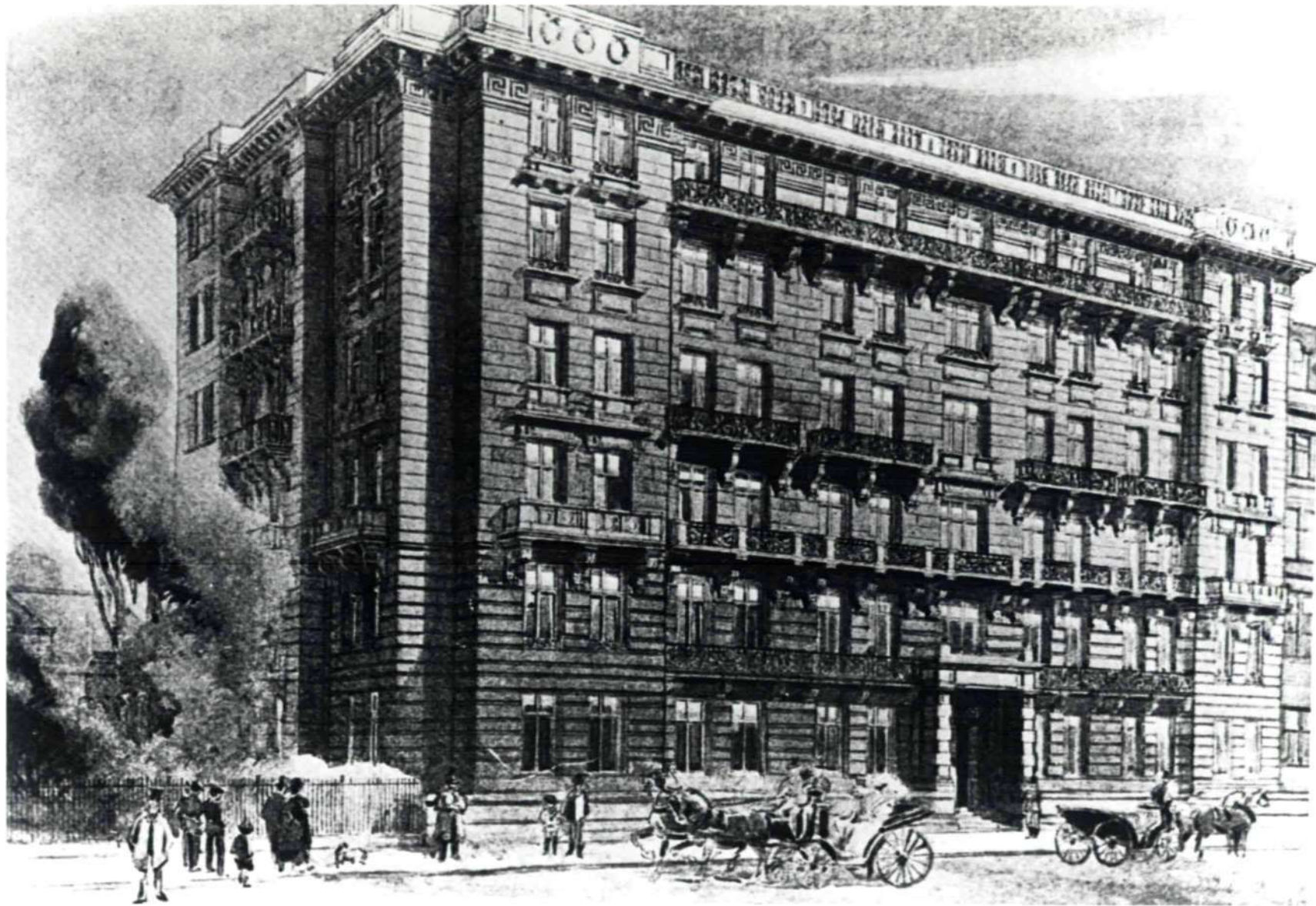

Fig. 12. 12 Hyde Park Place, London (Frank T. Verity, 1902-03).

Source: Service, *Edwardian Architecture and its Origins*, 449.



Fig. 13. Plymouth Apartments (1916, George H. Wells), east side of 82nd Street between 35th and 37th Avenues. Photo credit: Warren Shaw

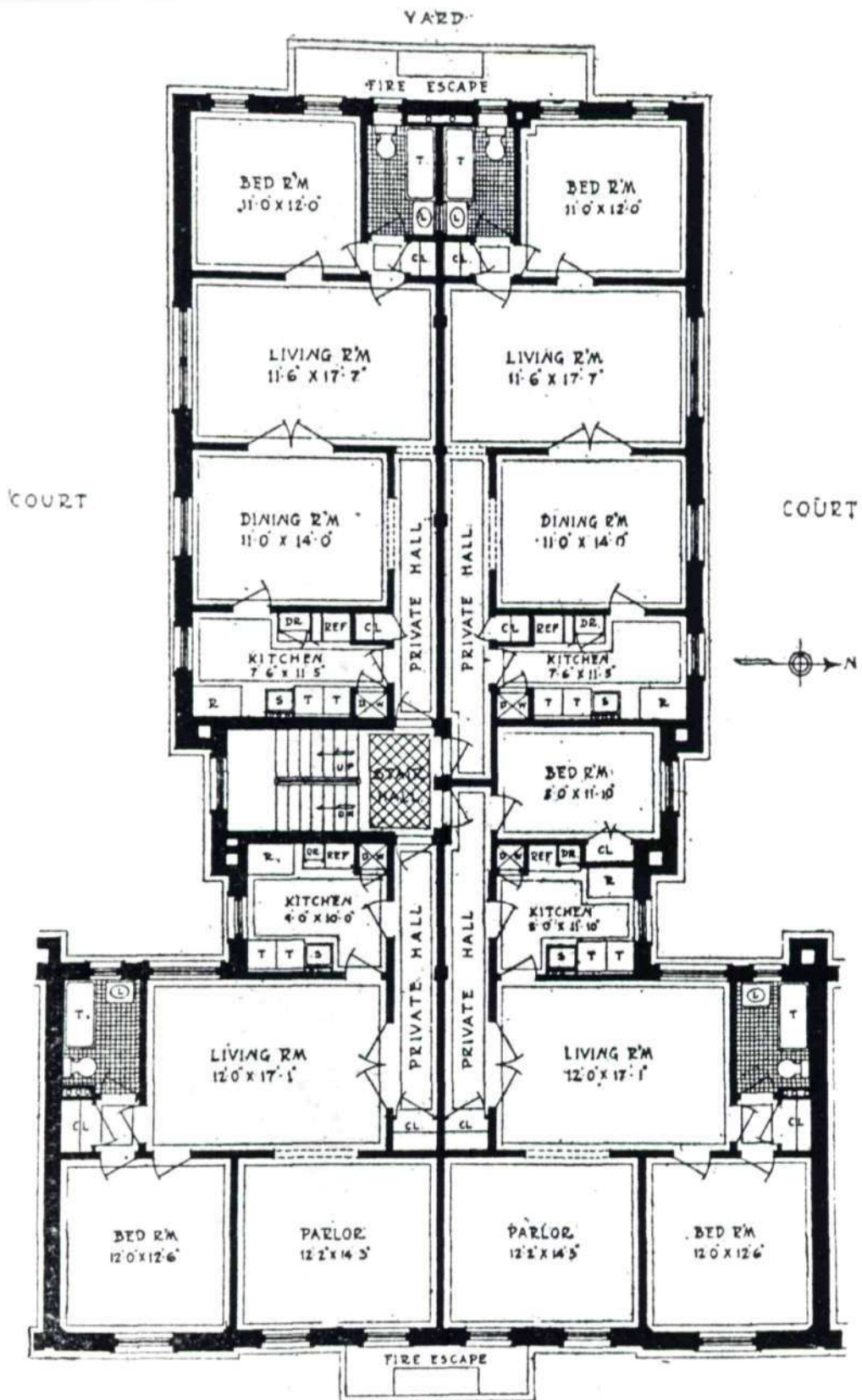

Fig. 14. Floor plan of Plymouth Apartments.

Source: *Real Estate Record & Guide* 97 (Mar. 25, 1916), 471.

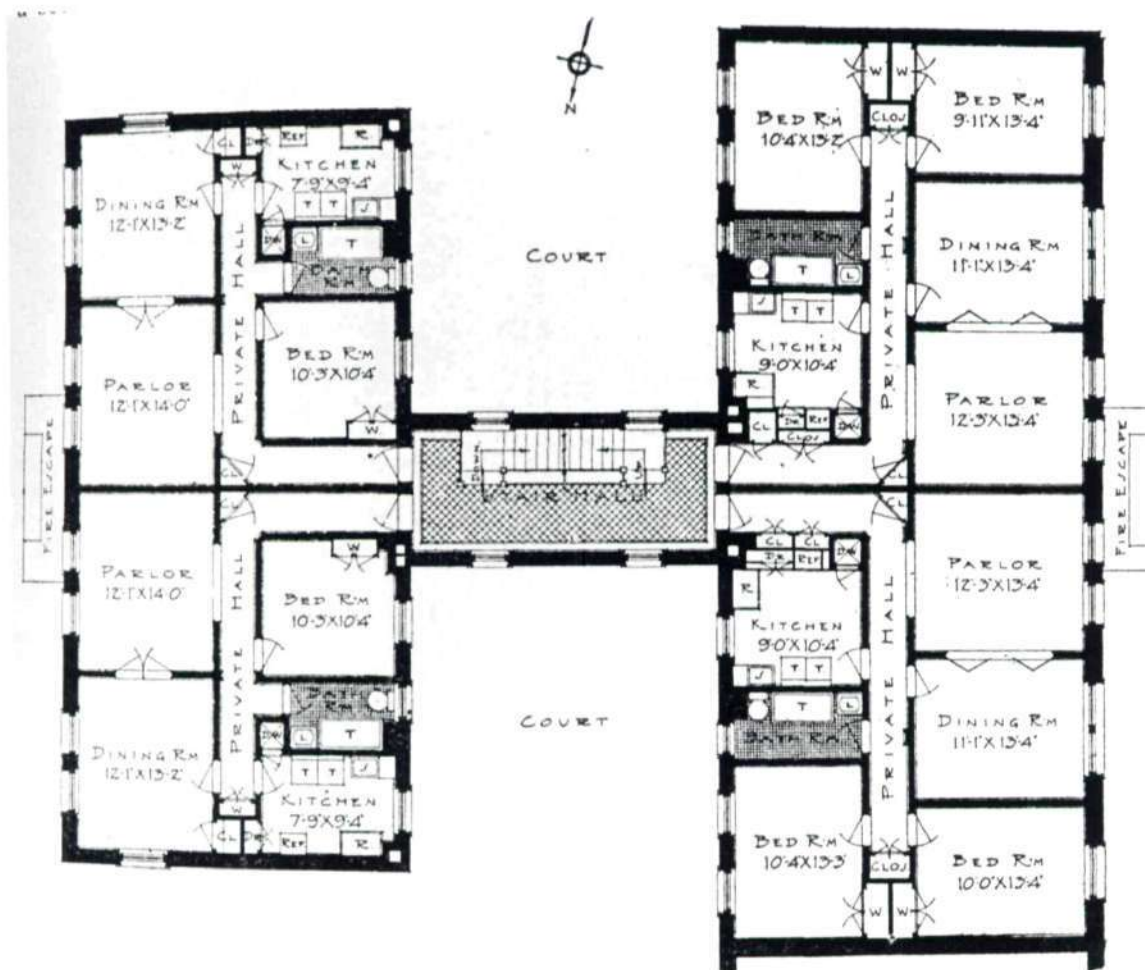

Fig. 15. Floor plan of Willow Court.

Source: *Real Estate Record & Guide* 97 (Mar. 25, 1916), 471.

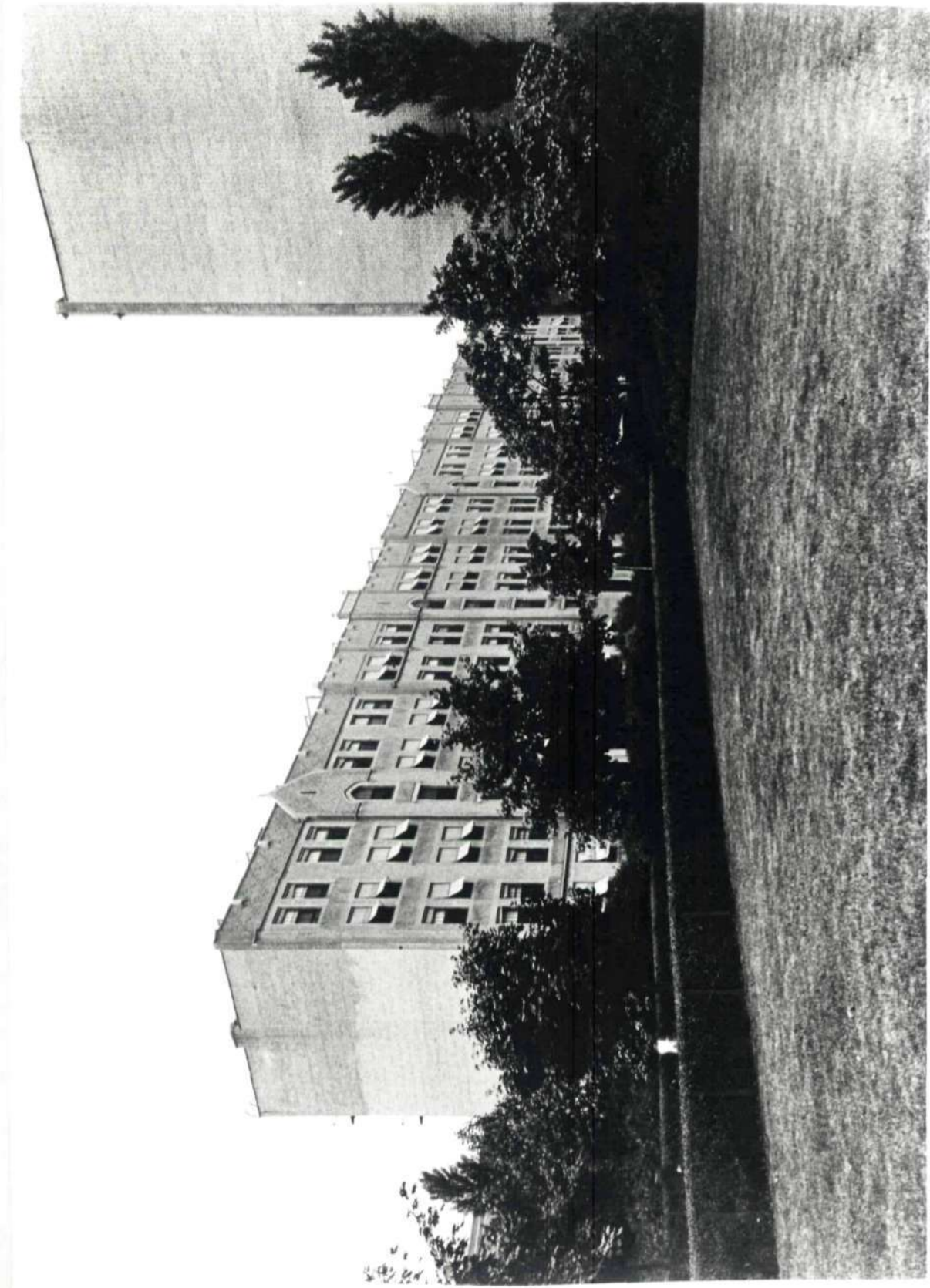

Fig. 16. Greystone Apartments (George H. Wells, 1916-18), c. 1925.

Source: Collection of Thomas Langan

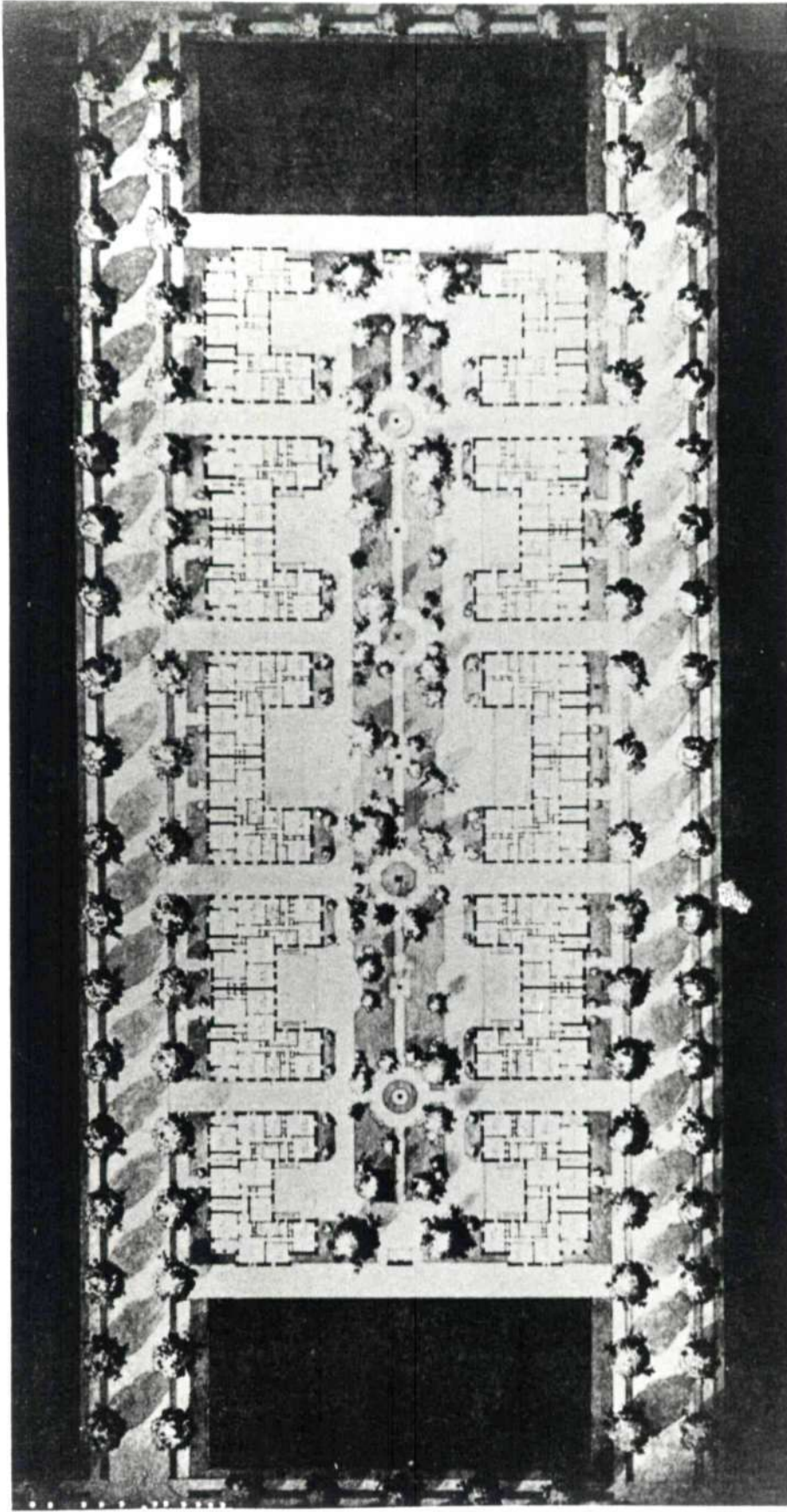

Fig. 17. Original plan of Linden Court (Andrew J. Thomas, 1919-21).

Source: Plunz, *A History of Housing in New York City*.



Fig. 18. Linden Court, c. 1925.

Source: Collection of Thomas Langan



Fig. 19. Hawthorne Court (George H. Wells, 1921-22), entrance detail, c. 1940.

Source: Collection of Thomas Langan



Fig. 20. Laburnum Court (George H. Wells, 1921-22), c. 1925.

Source: Collection of Thomas Langan



Fig. 21. Cambridge Court (George H. Wells, 1922), c. 1925.

Source: Collection of Thomas Langan



Fig. 22. View looking east on 34th Avenue, c. 1935.

Source: Collection of Thomas Langan

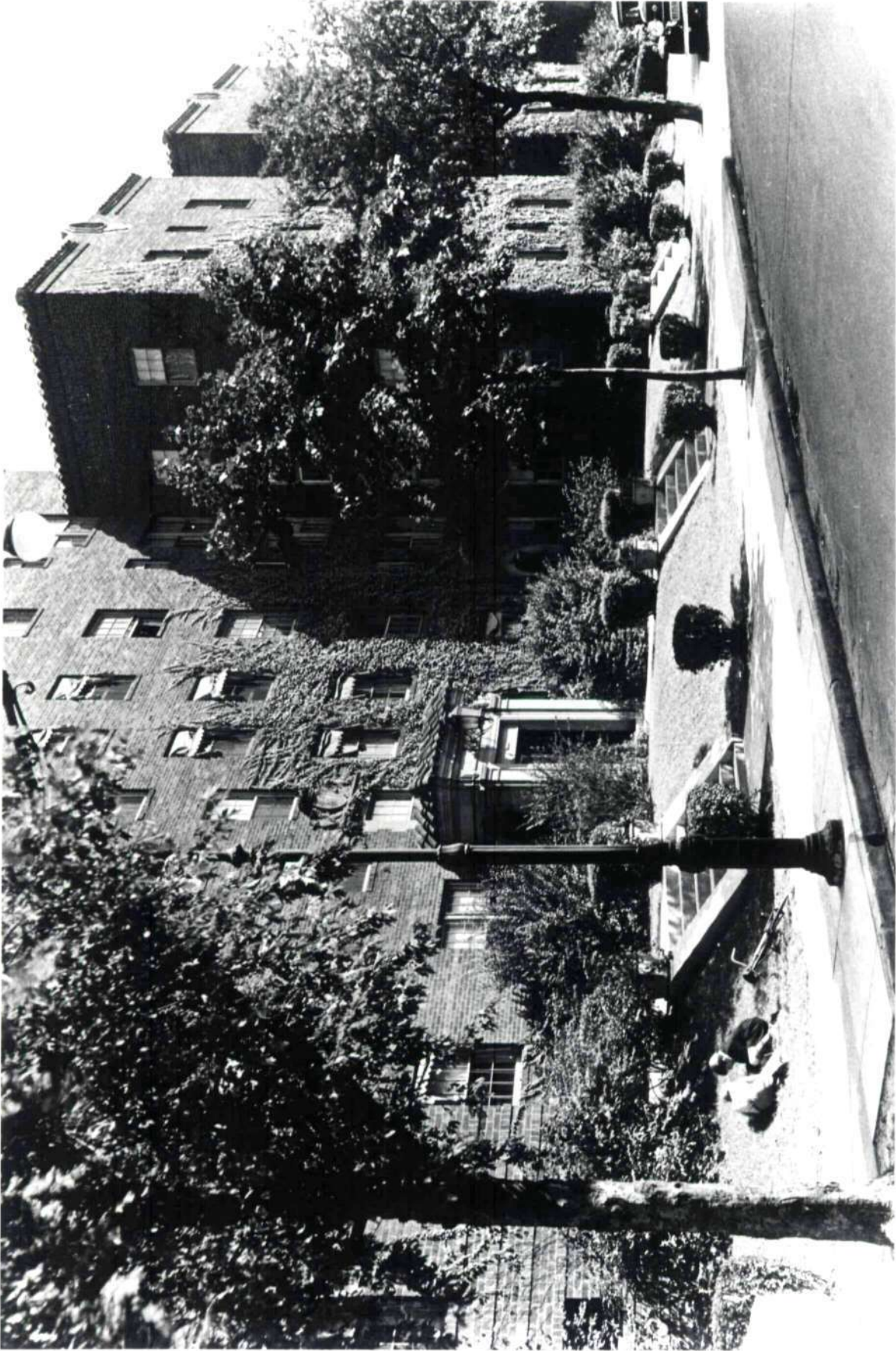
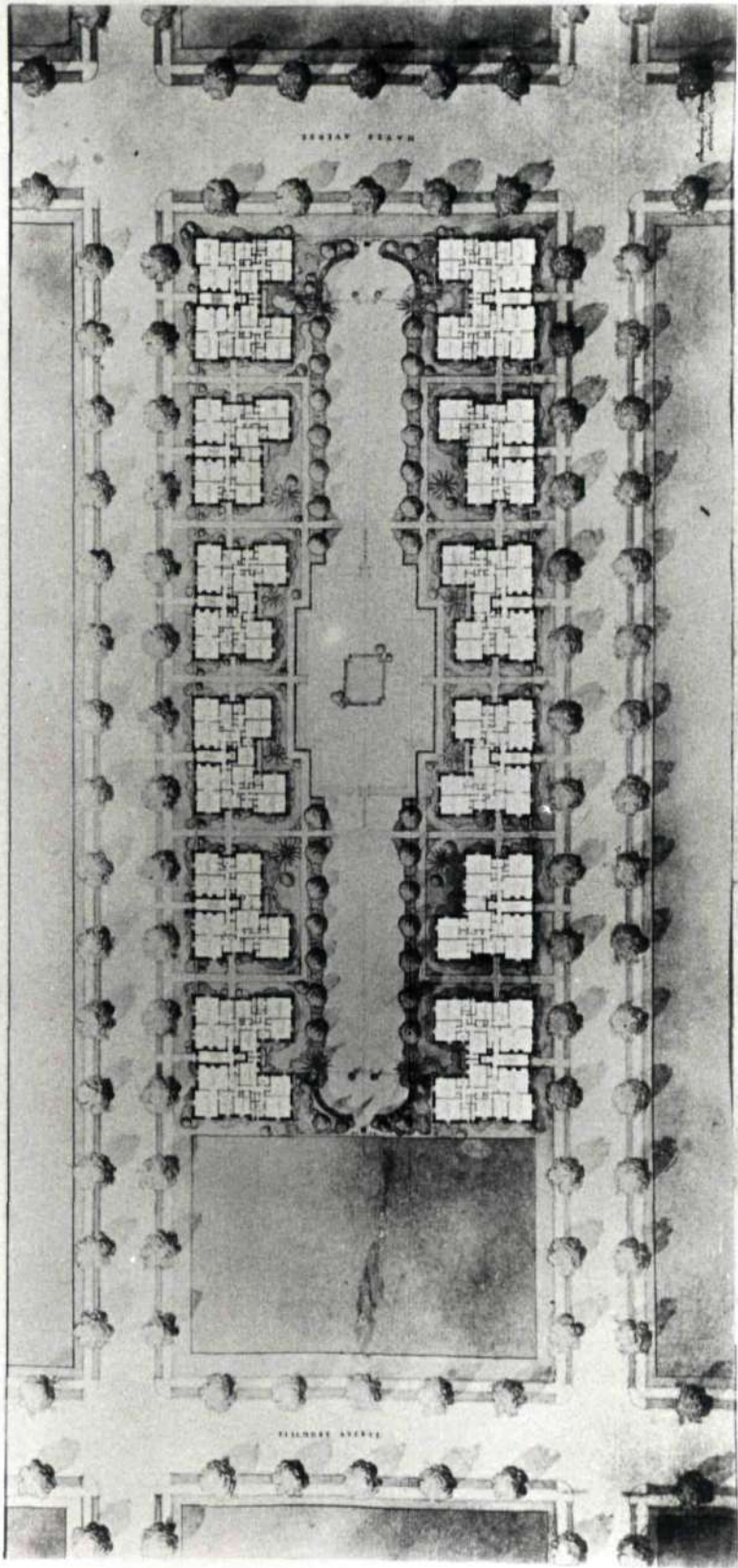

Fig. 23. Spanish Gardens (Andrew J. Thomas, 1924-26), c. 1935.

Source: Collection of Thomas Langan



Birds-eye view of Chateau Gardens showing garden lay-out and percentage of block area built upon.

Fig. 24. Plan for the Chateau (Andrew J. Thomas, 1922), c. 1921-22.

Source: Collection of Thomas Langan

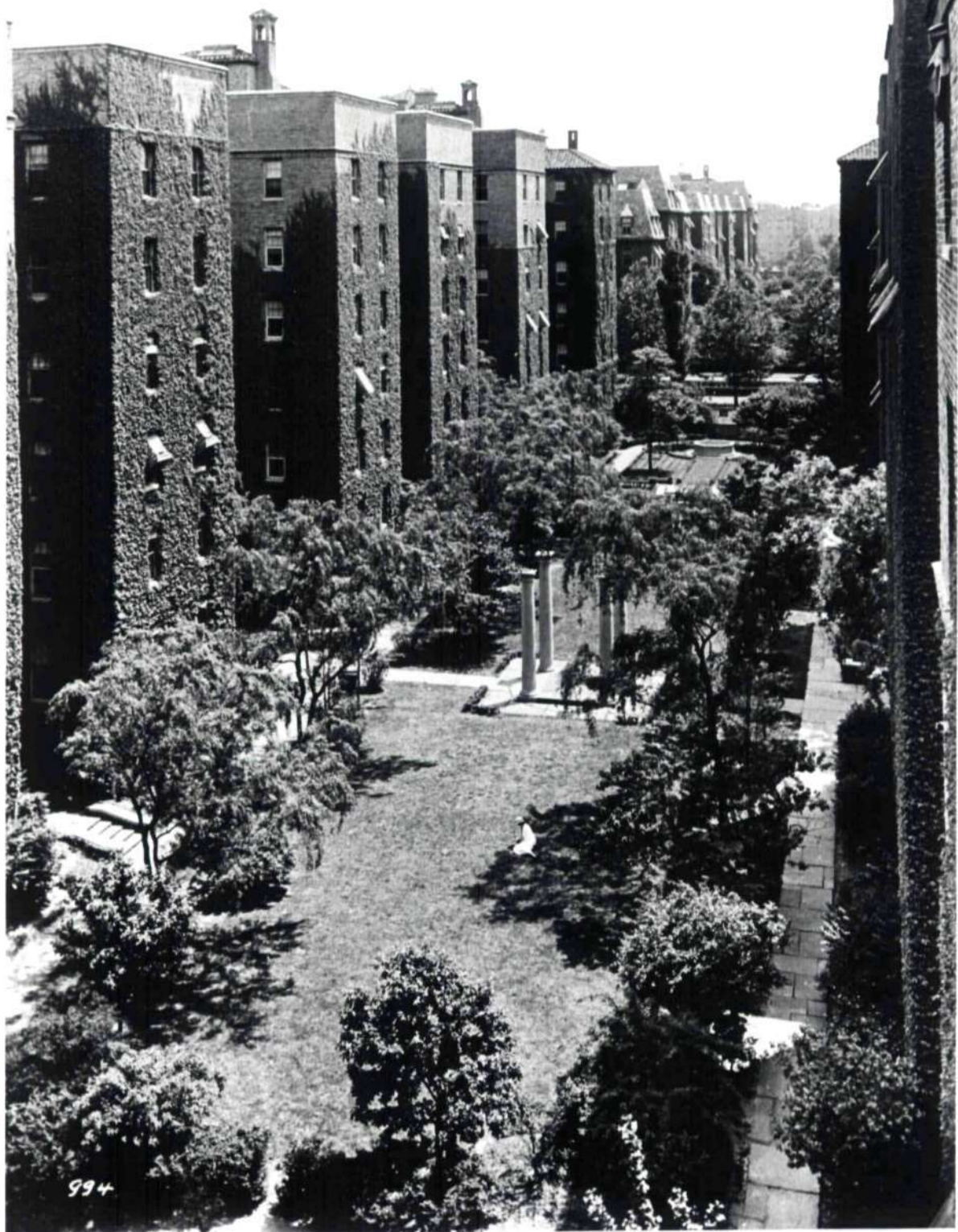

Fig. 25. View looking south from the Towers showing a three-block long vista of the interior gardens of the Towers, the Chateau, and the Greystone Apartments, c. 1930.

Source: Collection of Thomas Langan

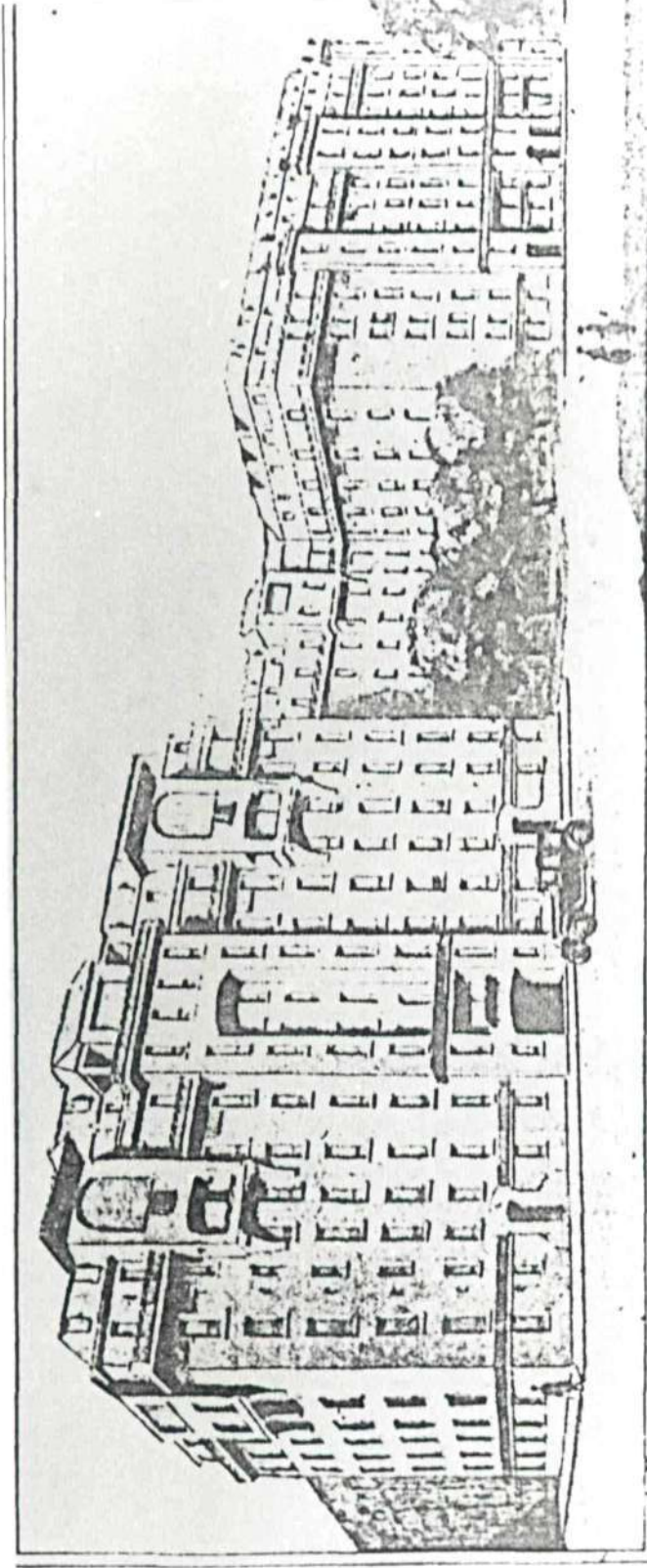

Fig. 26. Society of Cooperative Enterprises, Paris, illustration.

Source: *New York Times*, Mar. 25, 1923, sect. 10, p. 1.



Fig. 27. Garden Homes (C.F. & D.E. McAvoy, 1925),
east side of 87th Street between 35th and 37th avenues, c. 1926.

Source: Collection of Thomas Langan



Fig. 28. Garden Homes (C.F. & D.E. McAvoy, 1926),
west side of 87th Street between 35th and 37th avenues, c. 1926.

Source: Collection of Thomas Langan



Fig. 29. Garden Homes (C.L. Varrone, 1926),
west side of 88th Street between 34th and 35th Avenues, 1975.

Photo credit: David Bishop, LPC

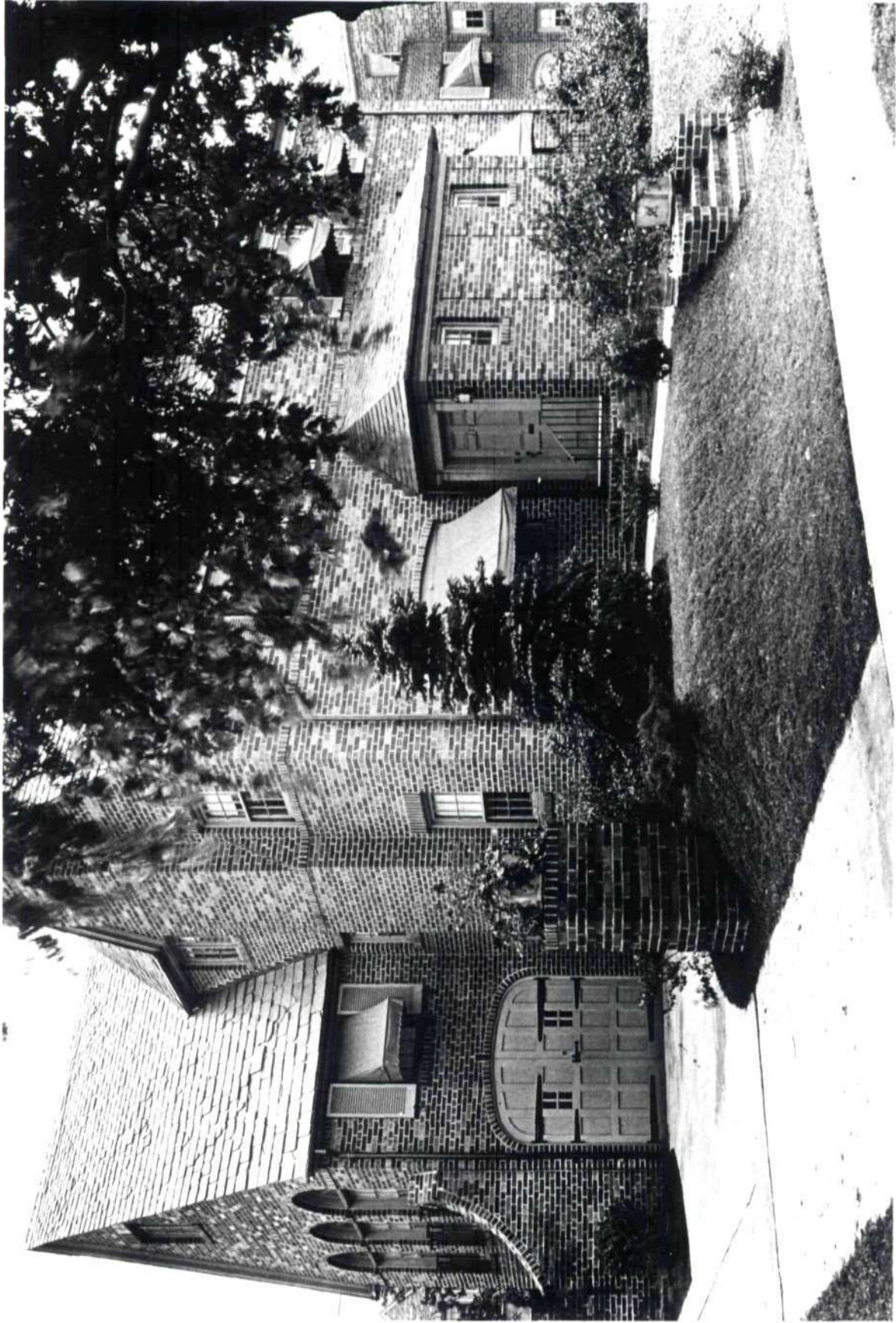

Fig. 30. Garden Homes (Robert Tappan, 1926-27), c. 1930.

Source: Collection of Thomas Langan



Fig. 31. Plymouth Houses (Pierce Kiesewetter, 1928).

Photo credit: Warren Shaw



Fig. 32. Fillmore Hall (E. Adelson, 1930) in c. 1935, before rooftop alterations.
Lower right, original basement of St. Joan of Arc R.C. Church.

Source: Collection of Thomas Langan



Fig. 33. Georgian Hall (E. Adelson, 1930-31) in 1931.

Source: Collection of Thomas Langan



Fig. 34. Dunolly Gardens (Andrew J. Thomas, 1939), view of interior garden, c. 1940, prior to relandscaping.

Source: Collection of Thomas Langan

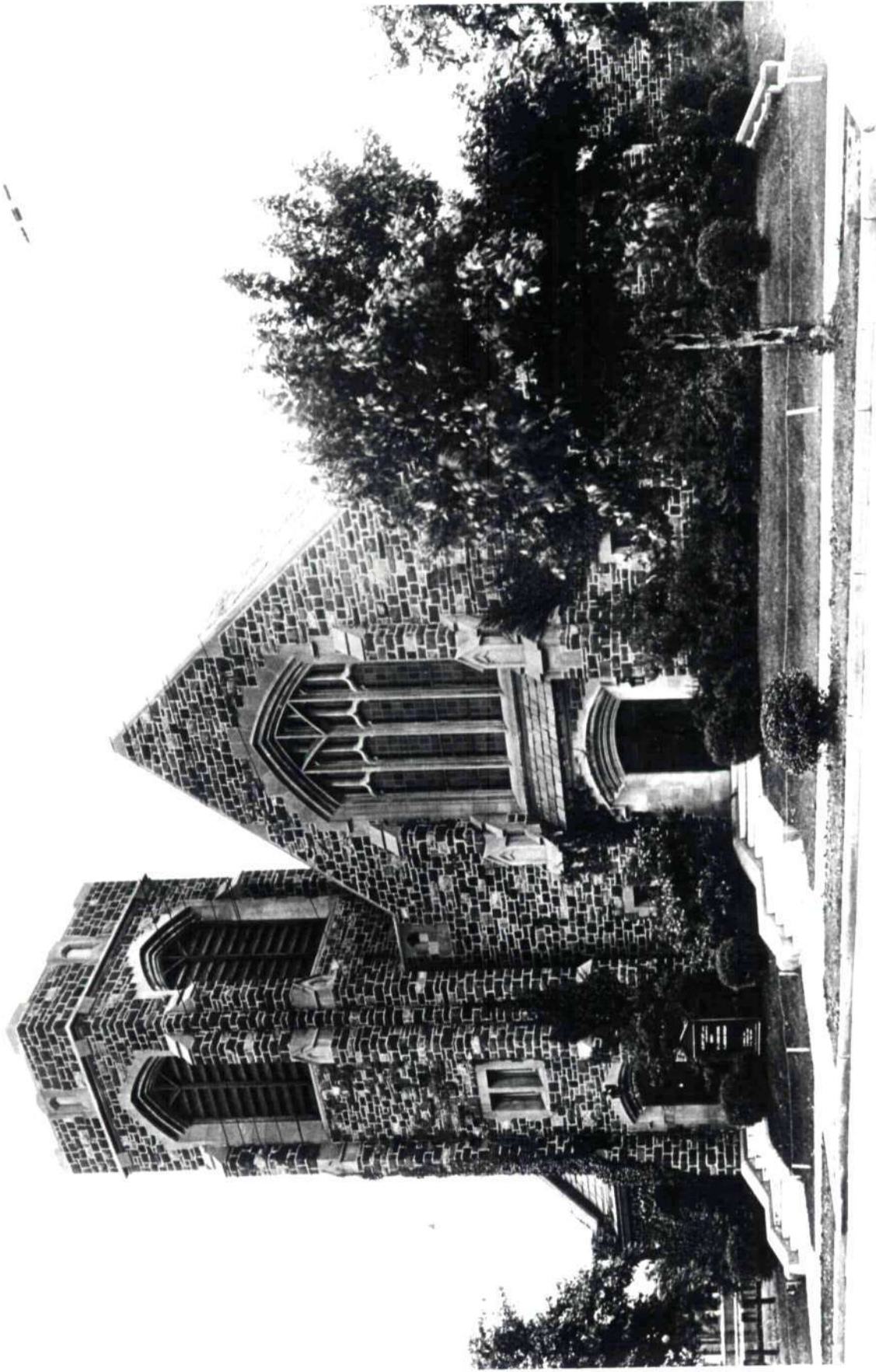

Fig. 35. Community Methodist Church (F.P. Platt, 1920-23), c. 1925.

Source: Collection of Thomas Langan



Fig. 36. St. Joan of Arc R.C. Church (W.A. Schlusing, 1949-51). (see also Fig. 32.)

Photo credit: Warren Shaw



Fig. 37. U.S. Post Office, Jackson Heights (Benjamin C. Flournoy, 1936-37).

Photo credit: Warren Shaw



Fig. 38. Queensboro Corporation Headquarters (Morrell Smith, 1928), southwest corner of 37th Avenue and 82nd Street, c. 1935.

Source: Collection of Thomas Langan

NORTHERN BOULEVARD - South Side

Northern Boulevard between 82nd and 83rd Street (South Side)

82-02—82-04 Northern Boulevard

See: 33-01—33-21 82nd Street

34TH AVENUE — North Side

34th Avenue between 80th Street and 81st Street (North Side)

80-01 34th Avenue

See: 33-15—33-51 80th Street

34th Avenue between 81st Street and 82nd Street (North Side)

SAINT MARK'S EPISCOPAL CHURCH

81-01—81-11 34th Avenue (a/k/a 33-53 81st Street and 33-50 82nd Street)

Block/lot: 1254/32

Type: Church
Stories: 2
Style: Modern Gothic

Date: 1927 [NB 18272-1926]
Architect: Robert Tappan
Owner: Vestry of St. Mark's Church

and

Type: Parish House
Stories: 2
Style: French Provincial

Date: 1948 [Karatzas]
Architect: undetermined
Owner: Vestry of St. Mark's Church

Designed in a Modern Gothic style by Robert Tappan, best known as the architect for several groups of houses in Jackson Heights, the picturesque St. Mark's Episcopal Church was built in 1927. It occupies a large landscaped site on the north side of 34th Avenue between 81st and 82nd streets, and is joined to the north by a Parish House, built in 1948, which faces 82nd Street. The property is lined by an iron fence.

The St. Mark's congregation had worshipped in storefront spaces on 37th Avenue since 1923. A fundraising campaign begun in 1925, in which specially inscribed bricks were sold for \$1.00 each, helped raise money for the construction of the church; in June, 1927, the cornerstone was laid and the church opened with a Christmas Eve service that year.

The picturesque church has stone facing of random ashlar and a steeply pitched, cross-gabled slate roof. The gable ends and clerestory are punctuated by Gothic (pointed-arch) windows in smooth-faced keyed surrounds. There are projecting, gabled entrance porches on the west end (reached via a path in the church yard) and on 34th Avenue. The west entrance facing 81st Street has massive wood double doors adorned with panels; the 34th Avenue entrance is smaller, containing one heavy wooden door with strapwork hinges. The stained glass windows are partially obscured by a protective plastic covering.

The Parish House is connected to the north side of the church. Its facades are stucco with masonry quoins and it has a hipped slate roof.

Sources: *Jackson Heights News*, Mar. 6, 1925, p. 5; June 11, 1927, p. 7; Christmas number, 1927, p. 7.
Karatzas, 104, 106.

34th Avenue between 82nd Street and 83rd Street (North Side)

82-01 34th Avenue

See: 33-53 82nd Street

34TH AVENUE — South Side

34th Avenue between 78th Street and 79th Street (South Side)

DUNOLLY GARDENS

78-02—78-20 34th Avenue and 34-02—34-42 79th Street and 78-01—78-19 35th Avenue and 34-01—34-41 78th Street

Block/lots: 1265/1, 11, 30, 33, 58, 52

78-02—78-20 34th Avenue
(a/k/a 34-02 79th Street and
34-01 78th Street) [1265/1]
34-20 79th Street [1265/11]

34-40—34-42 79th Street [1265/30]
78-01—78-19 35th Avenue [1265/33]
34-21 78th Street [1265/58]
34-41 78th Street [1265/52]

Type: Garden Apartments (6 buildings)
Stories: 6 with basement
Style: Moderne

Date: 1938-39*
Architect: Andrew J. Thomas
Developer: Garden Housing Corp.

- *No. 78-02--78-20 34th Avenue — NB 7769-1938
- *No. 78-01--78-19 35th Avenue — NB 7768-1938
- *No. 34-21 78th Street — NB 7765-1938
- *No. 34-41 78th Street — NB 7770-1938
- *No. 34-20 79th Street — NB 7666-1938
- *No. 34-40--34-42 79th Street — NB 7767-1938

Constructed in 1938-39 and designed by Andrew J. Thomas, an architect who two decades earlier had been a pioneer in designing garden apartment complexes in Jackson Heights, Dunolly Gardens was the last such project built within the historic district. The complex consists of six large freestanding buildings -- two on each street and one on each avenue -- arranged around a large common garden at the interior of the block. It is the only complex in the district to occupy an entire block, including both avenue ends. Each six-story-and-basement brick building, U-shaped in plan, is sited with a broad, simply landscaped entrance court at the front. The massing is further modulated by stepped bay projections in the courtyards and by asymmetrical lightcourts at the sides of the buildings. Passageways between the buildings provide views into the garden from the street.

The six buildings in the complex are nearly identical; the notable difference between the two buildings on the avenue fronts and the four buildings on the street fronts is in the treatment of the entrance courts.

The spare Moderne design of Dunolly Gardens contrasts with the historically-based designs of Thomas's earlier complexes in the district, among them the **The Chateau** and **The Towers**, located nearby. The modulated and sharply-angled massing, the brick banding and geometric patterning, the corner window openings, and the entrance bays which incorporate brick piers rising above the roofline (avenue buildings) or vertical brick channels culminating in angled parapets (street buildings) are all characteristic of the Moderne style. The entrance doors have horizontal glass panes which continue the streamline aesthetic. Iron railings line the steps leading to the entrances. The rear facades are designed in the same manner as the front facades.

Alterations include the removal of a parapet at No. 34-40 79th Street and the addition of tall iron fences at the entrances to the gardens.



Dunolly Gardens

Block 1265 Lots 1, 11, 30, 33, 52, 58

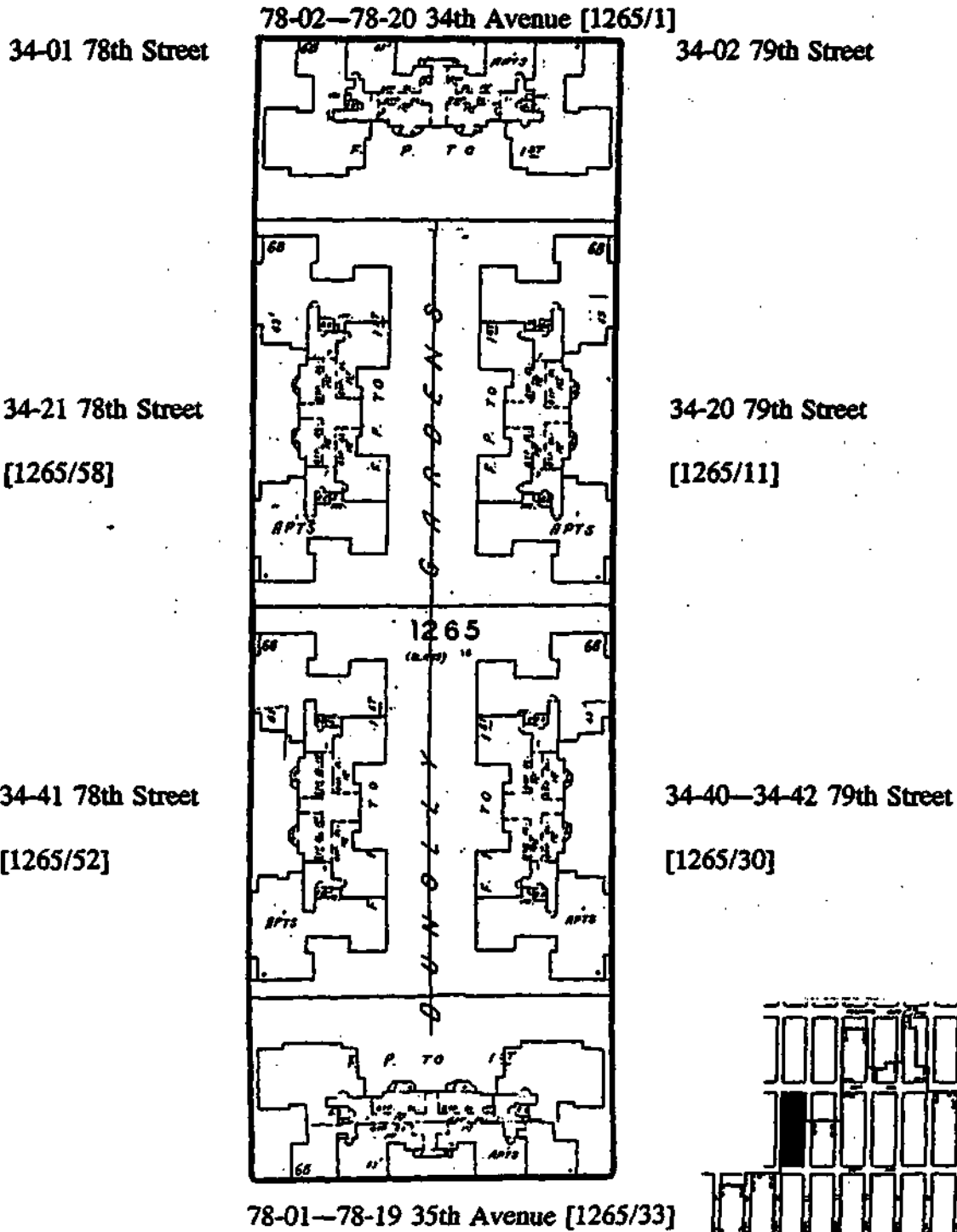

34th Avenue between 80th Street and 81st Street (South Side)

80-02 34th Avenue

See: 34-01—34-47 80th Street

34th Avenue between 81st Street and 82nd Street (South Side)

LAWRENCE HOUSE APARTMENTS

81-02—81-06 34th Avenue (a/k/a 34-01 81st Street)

Block/lot: 1268/1

Type: Apartment Building

Stories: 6 with basement

Style: Neo-Georgian (post-World War II)

Date: 1950-51 [NB 5304-1950]

Architect: Philip Birnbaum

Developer: Lawrence House Inc.

Designed by Philip Birnbaum and built in 1950-51, the six-story-and-basement Lawrence House Apartments is one of several apartment buildings constructed in the post-World War II era of development in Jackson Heights. Continuing the trend of the pre-War years, it is a large building planned with a recessed entrance court at the center of the 34th Avenue front and a long recessed areaway with lightcourts on its 81st Street front. There is a basement garage.

The simple brick facades of the building feature a modest application of Georgian-inspired ornamental details, limited to minimal brick patterning and the entrance porch, which has pilasters supporting a roof topped by an iron railing. The entrance doors have been replaced.

34th Avenue between 81st Street and 82nd Street (South Side)

OBAN COURT and PENRHYN COURT

Oban Court

81-14—81-20 34th Avenue
Block/lot: 1268/6

Penrhyn Court

34-02—34-06 82nd Street
Block/lot: 1268/10

Type: Apartment Buildings (2)
Stories: 5 with basement
Style: Edwardian

Date: 1914-15
Oban Court: [NB 3064-1914]
Penrhyn Court: [NB 3065-1914]
Architect: George H. Wells
Developer: Roosevelt Ave. Building Co., Inc.

Oban Court and Penrhyn Court, built in 1914-15, are among the early apartment building complexes in Jackson Heights designed by George H. Wells. Like that architect's other early walk-up apartments (**Laurel Court, Plymouth Court, The Colonial Apartments, and Willow Court**), Oban Court and Penrhyn Court were built near the street-car stop at 82nd Street and Northern Boulevard. The complex consists of two adjoining five-story-and-basement buildings, faced in gray Roman brick with stone trim. Penrhyn Court, located at the corner, has a long facade with a central entrance facing 82nd Street, and a shorter facade on 34th Avenue. The facade of Oban Court, facing 34th Avenue, is identical to the avenue facade of the adjacent Penrhyn Court, except for the former's central entrance on the avenue. The buildings share a small interior courtyard.

In style, Oban Court and Penrhyn Court draw on the neo-classical aesthetic of the Edwardian era in England. The design of each building suggests pavilions flanking intermediate bays, an effect achieved through the use of slightly projecting tripartite windows, patterned brick window surrounds, and stepped parapets. Each building has a rectangular stone-faced entrance surround with the name of the building inscribed above the door; the glass and iron double-doors with transoms remain intact. Other ornamental details include the modillioned cornices, bandcourses, and decorative iron brackets supporting the fire escapes.



Oban Court and Penrhyn Court

Block 1268 Lot 6 and Block 1268 Lot 10

81-14—81-20 34th Avenue [1268/6]

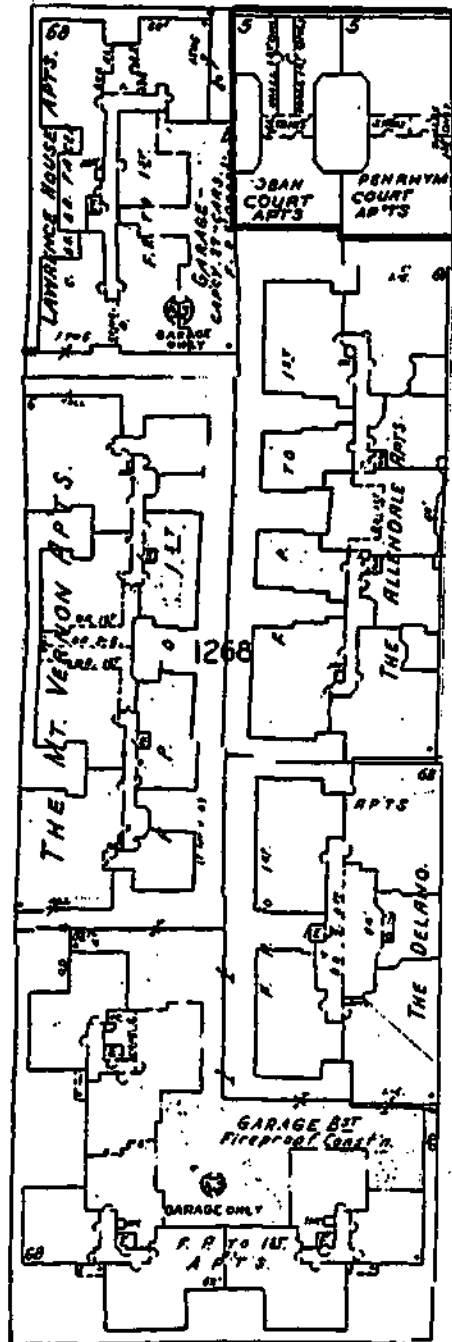

34-02—34-06 82nd Street
[1268/10]

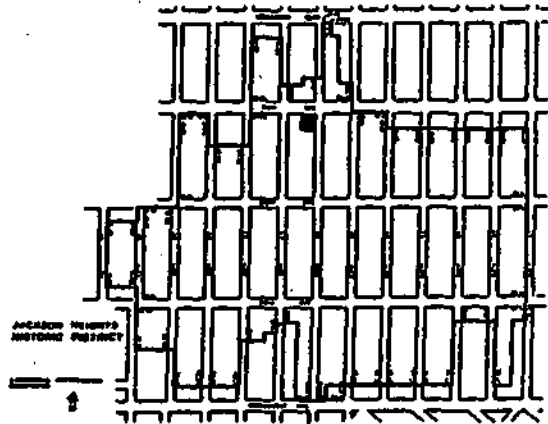

34th Avenue between 82nd Street and 83rd Street (South Side)

82-02 34th Avenue (a/k/a 34-01 82nd Street)—82-20 34th Avenue (a/k/a 34-02—34-06 83rd Street)

Block/lots: 1443/1, 6

82-02—82-06 34th Avenue
(a/k/a 34-01 82nd Street) [1443/1]

82-16—82-20 34th Avenue
(a/k/a 34-02—34-06 83rd Street) [1443/6]

Type: Apartment Buildings (2)
Stories: 6 with basement
Style: Neo-Romanesque

Date: 1929-30*
Architect: Alfred H. Eccles
Developer: Killianna Realty & Construction Co.

*Nos. 82-16—82-20 34th Avenue — NB 6629-1929

*No. 34-01 82nd Street — NB 7530-1929

Built in 1929-30 to designs by Alfred A. Eccles, these two six-story-and-basement buildings are designed as one unit occupying an end-block site on 34th Avenue. The blockfront is broken up into three sections by recessed lightcourts which serve as entrance courts to the two buildings. Narrow gardens line the sidewalks.

Neo-Romanesque in style, the multi-colored brick buildings are trimmed in stone and terra cotta. Ornamental details typical of that style include a base of brick laid up to imitate rustication, arched stone entrances with cartouches, elaborately carved stone lintels at the first story, quoins and attached colonnettes at the corners of the upper stories, brick bandcourses, blind stone arches at the top-story windows, and stone shields at the roofline. The original glass entrance doors with iron grillework survive. It appears that the shallow pent-roof parapets have been resurfaced. The plain rear elevations of the buildings and a small landscaped rear garden are visible from 82nd and 83rd Streets.

34th Avenue between 83rd Street and 84th Street (South Side)

83-02 and 83-16 34th Avenue

See: 34-01—34-09 83rd Street

35TH AVENUE — North Side

35th Avenue between 78th Street and 79th Street (North Side)

78-01—78-19 35th Avenue

See: 78-02—78-20 34th Avenue

35th Avenue between 79th Street and 80th Street (North Side)

ARLINGTON HALL

79-01—79-09 35th Avenue

Block/lot: 1266/38

Type: Apartment Building
Stories: 6 with basement
Style: Neo-Georgian

Date: 1939 [NB 1643-1937]
Architect: Joshua Tabatchnik
Developer: Lorber Lands

Built in 1939 to designs by Joshua Tabatchnik, the six-story-and-basement Arlington Hall is among the later apartment buildings erected in the historic district. Typical of that phase of development, the building occupies a site on 35th Avenue and is planned with a shallow recess at the avenue facade containing the entrance and a deep lightcourt at the side facing 79th Street.

Designed in the neo-Georgian style, the brick building features double-height temple front motifs at the upper stories, culminating in pediments with blind oculi at the roofline; brick laid to suggest quoins; brick dentil courses; broken pediments at first-story windows; and a window above the entrance with a Palladian motif. The original entrance has been replaced. Balconies have been removed from sixth-story windows (the brackets remain).

35th Avenue between 79th Street and 80th Street (North Side)

THE ELBERTSON APARTMENTS

79-15 35th Avenue

Block/lots: 1266/1000-1041

Type: Apartment Building
Stories: 6 with basement
Style: Neo-Georgian

Date: 1936-37 [NB 4953-1936]
Architect: Cohn Brothers
Developer: S. Cohen

Built in 1936-37 to designs by the Cohn Brothers, the six-story-and-basement Elbertson Apartments is among the later apartment buildings erected in the historic district. Typical of that phase of development, the building occupies an end-block site on 35th Avenue and is planned with a shallow recess on the avenue in which there is a full-height three-sided bay containing the main entrance and a deep lightcourt at the 80th Street facade. The building is similar in design to a number of other buildings along 35th Avenue, also produced by the Cohn Brothers firm: the **Georgian Gardens**, the **Madison Apartments**, and the **Jacksonian Apartments**.

The brick building is neo-Georgian in style. Elements which are typical of the style include the door surround with fluted pilasters supporting a broken arched pediment and the flanking windows with multi-pane arched sash; brickwork imitating quoins and brick and stone band courses; relieving arches with brick headers; stone keystones; iron balconettes at sixth-story windows; monumental temple front motifs

applied at the upper stories, culminating at the roofline in triangular pediments with oculi; and parapet balustrades. Brick walls with iron railings span the entrance to the lightcourt.

The building retains its original six-over-six double-hung wood sash windows. The entrance doors have been replaced.

35th Avenue between 80th Street and 81st Street (North Side)

STRATFORD HALL

80-01—80-19 35th Avenue
Block/lot: 1267/32

Type: Apartment Building
Stories: 6 with basement
Style: Neo-Romanesque

Date: 1941 [NB 81-1941]
Architect: Cohn Brothers
Developer: Queen Lind Assoc. Inc.

Built in 1941 to designs by the Cohn Brothers, the six-story-and-basement Stratford Hall is among the later apartment buildings erected in the historic district. Typical of that phase of development, the building occupies an end-block site on 35th Avenue and is planned with a large, recessed entrance court at the front and lightcourts at the sides along 80th and 81st Streets.

The design of the brick building is derived from the neo-Romanesque style with a modest application of architectural details. These include the Tudor-arched entrance portal, set into a three-sided full-height bay; paneled wood and glass doors with iron grilles; brick keyed window openings at first-story windows; parapets pierced with openings; and corbeled towers rising above the roofline. Low brick walls span the entrances to the court areas.

35th Avenue between 81st Street and 82nd Street (North Side)

THE WOODSTOCK APARTMENTS

81-01—81-15 35th Avenue (a/k/a 34-49 81st Street)
Block/lot: 1268/33

Type: Apartment Building
Stories: 6
Style: Neo-Georgian (post-World War II)

Date: 1949 [NB 1893-1949]
Architect: Philip Birnbaum
Developer: Woodstock House Inc.

Designed by Philip Birnbaum and built in 1949, the six-story Woodstock Apartments is one of several apartment buildings constructed in the post-World War II era of development in Jackson Heights. Continuing the trend of the pre-War years, it is a large building on an L-shaped site and is planned with broad and deep lightcourts which break up the long street fronts into smaller units. There are three entrances: one in the 81st Street court and one in each of the end courts of the 35th Avenue frontage. There is a basement garage. The perimeter garden areas are enclosed by low picket fences.

The simple brick facades of the building feature a modest application of Georgian-inspired ornamental details, limited to the projecting, flat-roofed entrance porches which are set into the corners of their respective courts. The building's original cornice has been replaced by a corrugated metal parapet.

35th Avenue between 82nd Street and 83rd Street (North Side)

82-01 35th Avenue

See: 34-57 82nd Street

35th Avenue between 82nd Street and 83rd Street (North Side)

SENATE GARDENS

82-15 35th Avenue

Block/lot: 1443/33

Type: Apartment Building

Stories: 6 with basement

Style: Neo-Georgian

Date: 1937 [NB 779-1937]

Architect: Seelig & Finkelstein

Developer: Star Heights Building Co.

Built in 1937 to designs by Seelig & Finkelstein, the six-story-and-basement Senate Gardens is among the later apartment buildings erected in the historic district. Typical of that phase of development, the building occupies an end-block site on 35th Avenue and is planned with a large, recessed entrance court at the front of the building.

Neo-Georgian in style, the building is faced in red brick with white trim and is similar in its design to two slightly earlier buildings designed by the Cohn Brothers: the adjacent **Georgian Gardens at 34-57 82nd Street** and the **Colonial Arms at 34-20 83rd Street**, further north on the same block as the Senate. Ornamental elements include the door surround with paired pilasters and a broken pediment; low brick walls and brick and stone pedestals at the courtyard entry; brickwork imitating quoins and brick pilasters with stone bases and stylized stone capitals; brick bandcourses suggestive of entablatures; windows with stone surrounds set into keyed relieving arches; splayed stone lintels with keystones; and, at the roofline, parapet balustrades and brick pediments pierced by oculi. The original six-over-six wood sash windows remain.

Alterations include changes to the parapet wall, the replacement of entrance doors, and the removal of balconettes from second-story bays (the brackets remain).

35th Avenue between 83rd Street and 84th Street (North Side)

CEDAR COURT

83-01—83-09 35th Avenue
Block/lot: 1444/32

Type: Garden Apartments (1 building)
Stories: 4 with basement
Style: Neo-Romanesque

Date: 1924-25 [NB 15134-1924]
Architect: Andrew J. Thomas
Developer: Fillmore Building Corp.

Built in 1924-25, Cedar Court is one of three smaller garden apartment projects designed by Andrew J. Thomas in the mid-1920s and built on end-block sites (see **Hayes Court** and **Ivy Court**). At Cedar Court, the four-story-and-basement brick building is separated into multiple units by party walls and accessed by multiple entrances. The C-shaped structure is planned around an inner garden court; entrances to the building are located in the courtyard, which is entered via an iron gate on 35th Avenue. Small gardens line the sidewalks.

The style of Cedar Court continues the Mediterranean-inspired, neo-Romanesque design of the slightly-earlier **Towers**, one of Thomas's much larger complexes of the same period. The wings facing the avenue are massed with towers marking the stairhall bays and arcaded open loggias at the top story; the roofline is further enhanced by Spanish-tile roofs. Other decorative elements of the design include brick soldier courses at the base and blind brick arcades at the fourth story; stone balconettes; arched and square-headed entryways (leading to recessed entrances) with such details as molded brickwork and attached stone columns; and statuary at the corners of the loggias. Many original multi-pane double-hung wood windows survive.



Cedar Court

Block 1444 Lot 32

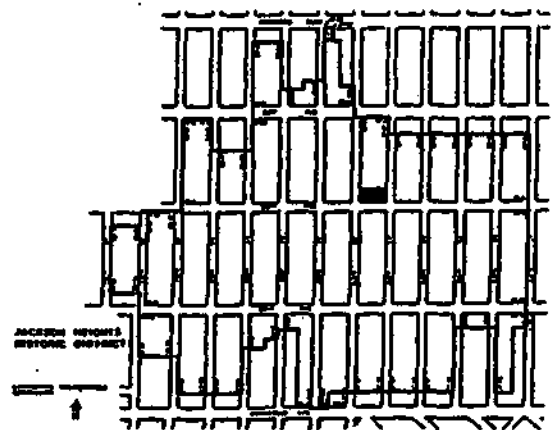
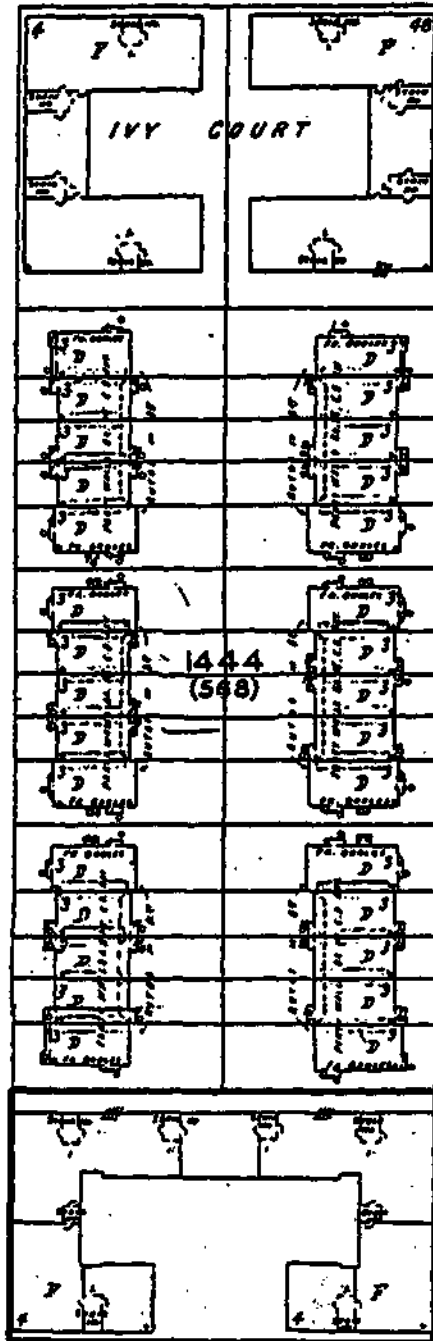

83-01-83-09 35th Avenue

35th Avenue between 84th Street and 85th Street (North Side)

WESTLEIGH APARTMENTS

84-01—84-19 35th Avenue
Block/lot: 1445/34

Type: Apartment Building
Stories: 6 with basement
Style: Neo-Georgian (post-World War II)

Date: 1947-48 [NB 7248-1946]
Architect: Morris Rothstein
Developer: Ranam Building Co.

Designed by Morris Rothstein and built in 1947-48, the six-story-and-basement Westleigh Apartments is one of several apartment buildings constructed in the post-World War II era of development in Jackson Heights. Continuing the trend of the pre-War years, it is a large building on an end-block site and is planned with two deep lightcourts and a shallow central recess at the avenue front. An alley at the rear leads to a basement garage.

The brick facades of the Westleigh feature Georgian-inspired ornamental details, including brickwork suggestive of stone quoins, dentils, modillions, and entablatures; a brick parapet with decorative iron railings in cutaway sections and with a brick pediment at the avenue facade; and a central, classically-inspired entrance set into the shallow recess of the avenue facade. Iron grilles are located at the flanking windows, and an iron balcony surmounts the entrance, fronting four windows with shutters. A small garden surrounds the building on all three sides and has split-rail fencing (not original).

35th Avenue between 85th Street and 86th Street (North Side)

QUEEN ELIZABETH APARTMENTS

85-01—85-15 35th Avenue
Block/lot: 1446/33

Type: Apartment Building
Stories: 6 with basement
Style: Moderne (Post-World War II)

Date: 1950-51 [NB 456-1950]
Architect: Hyman I. Feldman
Developers: Joseph Gerlo; Charles S. Freeman

Designed by Hyman I. Feldman and built in 1950-51, the six-story-and-basement Queen Elizabeth Apartments is one of several apartment buildings constructed in the post-World War II era of development in Jackson Heights. Continuing the trend of the pre-War years, it is a large building on an end-block site and is planned with a broad recessed entrance court at the center of the avenue front and lightcourts at the street fronts. The building is very similar to the Queen Victoria, located on the south side of 35th Avenue one block to the east, which was designed by Feldman for the same developers and built at roughly the same time. A driveway leads from 85th Street at the rear of the building to a basement garage. The entrance court is landscaped, and there are small gardens surrounding the building.

A late interpretation of the Moderne style, the brick building is distinguished by the horizontal expression of the brick banding on all facades and by the geometric header and stretcher brick patterning around the entrance. The double-leaf doors have square windows and are topped by a transom. Many of the original three-over-three windows with horizontal muntins survive.

35th Avenue between 86th Street and 87th Street (North Side)

FIRST CHURCH OF CHRIST, SCIENTIST

86-01--86-17 35th Avenue
Block/lot: 1447/35

Type: Church
Stories: 1 and 2
Style: Moderne

Date: 1927; 1951-53
[NB 14047-1926; Alt 1128-1951]
Architects: Arnold W. Brunner;
C. Faulkner
Owner: J. Branch

Followers of the Christian Science faith in Jackson Heights attended services in the Community Casino until 1923 when they moved into a storefront on 37th Avenue that had recently been vacated by the Community Church. Shortly before his death in 1925, Arnold W. Brunner was commissioned to design a neo-Georgian style church, of which only the basement level was constructed under the direction of Gehron & Ross, Brunner's successor firm. In 1953 a large Moderne style addition, designed by C. Faulkner of Chicago, was completed to the west of the original structure.

The 1927 basement wing is faced in brick and trimmed with limestone quoins, a water table, and an entablature. A projecting limestone entrance portico faces 35th Avenue. The geometrically patterned grilles on the entry doors and front windows are similar to those on the 1953 addition, and may have been added at that time. The 87th Street facade has paired multi-pane double-hung windows.

The 1953 wing is a square brick-faced building with a limestone pavilion facing 35th Avenue; that facade features a monumental semi-circular bay with tall multi-pane windows between fluted piers. (The wing bears a cornerstone with the date "1952.") Double doors with brushed metal grilles in a geometric design flank the projecting bay. Above the doors and windows are bold geometric patterns in relief. The 35th Avenue portion of the building is set on a low platform scaled by two flights of steps with brushed metal railings similar in design to the grilles on the doors. The plain brick west facade is partly hidden by plantings.

Source: Karatzas, 107.

35th Avenue between 87th Street and 88th Street (North Side)

THE LINCOLN APARTMENTS

87-01--87-11 35th Avenue
Block/lot: 1448/32

Type: Apartment Building
Stories: 6 with basement
Style: Moderne (Post-World War II)

Date: 1950 [NB 50-1950]
Architect: Kavy & Kavovitt
Developer: undetermined

Designed by Kavy & Kavovitt and built in 1950, the six-story-and-basement Lincoln Apartments is one of several apartment buildings constructed in the post-World War II era of development in Jackson Heights. Continuing the trend of the pre-War years, it is a large building on an end-block site and is planned with a large recessed entrance court at the center of the avenue front and lightcourts which cut away the corners of the building. A driveway at the rear of the building leads to a basement garage. The entrance court is landscaped, and there are small gardens surrounding the building.

A late interpretation of the Moderne style, the brick building has minimal ornamental detail, limited to bricks laid to suggest quoins, header brick bandcourses, and metal marquees above the two entrance doors in the courtyard.

35TH AVENUE — South Side

35th Avenue between 77th Street and 78th Street (South Side)

BERKELEY HALL/(now) BERKELEY GARDENS

77-02—77-12 35th Avenue (a/k/a 35-01 77th Street and 35-02 78th Street)

Block/lot: 1277/1

Type: Apartment Building
Stories 6 with basement
Style: Neo-Georgian

Date: 1936-37 [NB 4915-1936]
Architect: Joshua Tabatchnik
Developer: Berkeley Hall Inc.

Built in 1936-37 to designs by Joshua Tabatchnik, the six-story-and-basement Berkeley Gardens (formerly known as Berkeley Hall) is among the later apartment buildings erected in the historic district. Typical of that phase of development, the building occupies an end-block site on 35th Avenue and is planned with two lightcourts flanking a slightly recessed central gabled pavilion at the front and lightcourts at the sides. The central pavilion and the flanking courts are modulated with angled bays. The building is roughly contemporary with the **Berkeley Apartments**, also designed by Tabatchnik, which is located around the corner on 77th Street.

Faced in red brick with white trim, the building is neo-Georgian in style. A two-story wooden portico marks the entrance; a similar motif in stone, consisting of paired pilasters supporting an architrave, is repeated on the facades of the flanking sections on the avenue. Other neo-Georgian elements include the pitched roof with gabled dormers, pediments, and urns; brickwork imitating quoins and brick band courses; three-sided oriels at some second-story bays; and the false fanlight above the entrance.

35th Avenue between 78th Street and 79th Street (South Side)

THE JEFFERSON HALL APARTMENTS

78-02—78-12 35th Avenue (a/k/a 35-01 78th Street and 35-02 79th Street)

Block/lot: 1278/1

Type: Apartment Building
Stories: 6
Style: Neo-Georgian

Date: 1936-37 [NB 4914-1936]
Architect: Joshua Tabatchnik
Developer: Fillmore Gardens

Built in 1936-37 to designs by Joshua Tabatchnik, the six-story Jefferson Hall Apartments is among the later apartment buildings erected in the historic district. Typical of that phase of development, the building occupies an end-block site on 35th Avenue and is planned with a large, recessed entrance court at the front and lightcourts at the sides. Elements of the building's neo-Georgian design include temple-front motifs articulated in brick with stone trim at each of the two sections of the avenue facade, and projecting pediments at the northern end of each of the street facades. The elaborate main entrance surround is composed of masonry pilasters, a molded stone entablature, an arched pediment, and flanking metal lamps, set within a larger composition of masonry pilasters, a pediment, panels, and flat segmental arches. The metal and glass doors are replacements.

35th Avenue between 79th Street and 80th Street (South Side)

THE WILLIAM PENN APARTMENTS

79-02—79-10 35th Avenue (a/k/a 35-01 79th Street and 35-02 80th Street)

Block/lot: 1279/1

Type: Apartment Building

Stories: 6

Style: Neo-Georgian (post-World War II)

Date: 1951-52 [NB 353-1951]

Architect: Oscar I. Silverstone

Developer: H. Osias

Designed by Oscar I. Silverstone and built in 1951-52, the six-story William Penn Apartments is one of several apartment buildings constructed in the post-World War II era of development in Jackson Heights. Continuing the trend of the pre-War years, it is a large building on an end-block site and planned with lightcourts at each of the four corners of the building and a recessed entrance court at the center of the avenue front. The brick facades of the William Penn feature a modest application of Georgian-inspired ornamental details, limited to brickwork simulating corner quoins and two wood porches at the doorways in the corners of the entrance court; they are topped by iron railings. The east porch has been rebuilt. A one-story garage faces the rear alley and fronts on both 79th and 80th streets.

35th Avenue between 80th Street and 81st Street (South Side)

WINSLOW APARTMENTS

80-02—80-08 35th Avenue (a/k/a 35-01 80th Street and 35-02 81st Street)

Block/Lot: 1280/1

Type: Apartment Building

Stories: 6

Style: Neo-Georgian (post-World War II)

Date: 1950-51 [NB 6986-1950]

Architect: Philip Birnbaum

Developer: Juco Realty Corp.

Designed by Philip Birnbaum and built in 1950-51, the six-story Winslow Apartments is one of several apartment buildings constructed in the post-World War II era of development in Jackson Heights. Continuing the trend of the pre-War years, it is a large building on an end-block site and planned with a broad and deep entrance court at the center of the avenue front and lightcourts at the street fronts on 80th and 81st Streets. There is an alleyway at the rear which leads to a basement garage. The brick facades of Winslow Apartments feature a modest application of Georgian-inspired ornamental details, including the small wood entrance porch with classical columns supporting an entablature; cast-stone lunettes above the windows over the porch; and stringcourses at the first, fifth and sixth stories.

35th Avenue between 81st Street and 82nd Street (South Side)

COMMUNITY UNITED METHODIST CHURCH COMPLEX

81-02—81-10 35th Avenue (a/k/a 35-01 81st Street and 35-02 82nd Street)

Block/lot: 1281/1

Type: Church
Stories: 2
Style: Neo-Tudor

Date: 1920-23 [NB 3907-1920]
Architect: F.P. Platt
Owner: M.E. Church of Jackson Heights

and

Type: Sunday School
Stories: 2
Style: Modern

Date: 1953-54 [NB 7395-1952]
Architect: Holden McLaughlin & Assoc.
Owner: M.E. Church of Jackson Heights

The Community Church, one of the first churches to be erected in the community of Jackson Heights, was built to serve a congregation initially composed of members of a variety of Protestant denominations. The fledgling congregation received encouragement and aid from the Queensboro Corporation, which provided a storefront to serve as the church's first home. In 1919, the congregation voted to join the Methodist Episcopal Church, which offered to provide a resident pastor and \$50,000 toward a building campaign. The Queensboro Corporation in turn donated the land on which the new building would stand, with the stipulation that construction begin by September, 1920. (The church bears a cornerstone with the date, "1920"; it was completed in 1923.)

The church occupies the western half of the blockfront on the south side of 35th Avenue between 81st and 82nd Streets. The firm of F.P. Platt designed the building in a neo-Tudor manner. The church, with its facades of random stone ashlar, is massed with a steeply pitched slate roof and an adjoining short square tower. The 81st Street facade has small buttresses with limestone coping. Window openings have keyed limestone surrounds; multi-pane Tudor-arched windows with leaded glass over the main portal and along 81st Street have stone mullions. The church retains its sets of wooden doors with strap hinges. The small matching wing on 35th Avenue, to the east of the church, was a later addition (the lintel above the door bears the date "1953"); it connects the church with the 1953-54 Sunday school building, a simple, two-story, utilitarian structure on the 82nd Street corner. Behind the complex is a garden.

Sources: *Jackson Heights News* 8, no. 12 (June 6, 1923), 4; 18, no. 16 (Aug. 24, 1934), 1.



Community United Methodist Church Complex

Block 1281 Lot 1

81-02—81-10 35th Avenue

35-01 81st Street

[1281/1]

35-02 82nd Street

[1281/1]

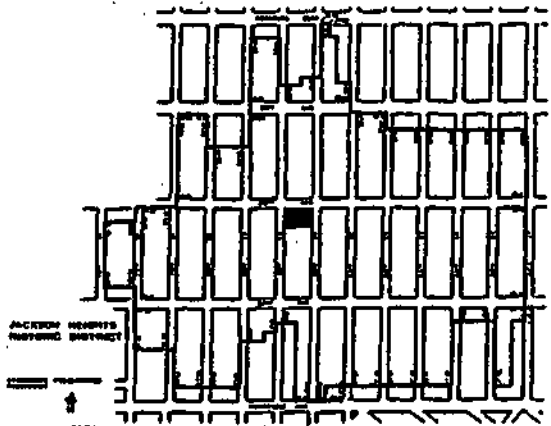
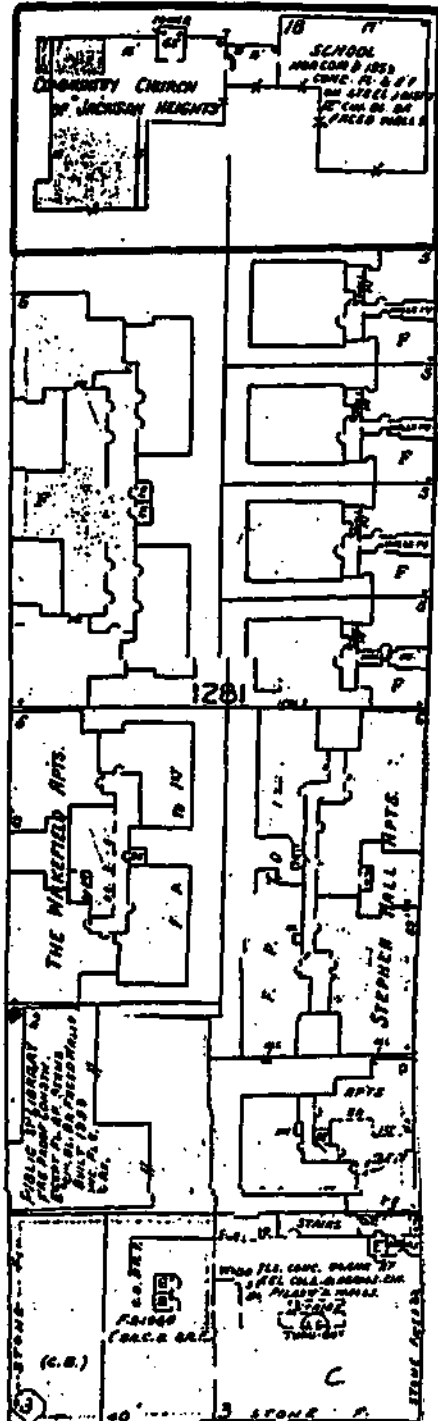

35th Avenue between 82nd Street and 83rd Street (South Side)

SAINT JOAN OF ARC R.C. CHURCH COMPLEX

*Consisting of: Saint Joan of Arc Church, Convent, School,
Ward Meehan Meeting Hall and Rectory*

Block/lots: 1456/1 and 4

Type: Church [35-02 83rd Street]
Stories: 4
Style: Neo-Romanesque

Date: 1949-51 [ALT 1099-1949]
Architect: W.A. Schlusing
Owner: R.C. Church of St. Joan of Arc

Type: Rectory [82-00 35th Avenue]
Stories: 4 with basement
Style: Neo-Gothic

Date: 1926 [NB 3926-1926]
Architect: Murphy & Lehman
Owner: R.C. Church of St. Joan of Arc

Type: School [35-07 82nd Street]
Stories: 3 with basement
Style: Stylized Neo-Gothic

Date: 1924 [NB 10268-1924]; 1936-37
[ALT 4186-1936]
Architect: Gustave E. Steinback;
Henry V. Murphy
Owner: R.C. Church of St. Joan of Arc

Type: Convent [35-24 83rd Street]
Stories: 3 with basement
Style: Stylized Neo-Gothic

Date: 1940 [NB 3572-1940]
Architect: Henry V. Murphy
Owner: R.C. Church of St. Joan of Arc

Ward Meehan Meeting Hall [35-29 82nd Street]
Type: Meeting Hall
Stories: 1
Style: International Style

Date: 1961 [NB 127-1960]
Architect: LaPierre & Litchfield
Developer: R.C. Church of St. Joan of Arc

Roman Catholic residents of Jackson Heights attended services at the Community Casino and at Saint Bartholomew's Church in Elmhurst until 1920, when the Brooklyn Diocese organized the Saint Joan of Arc parish. That year, a wood and stucco church (now demolished) was constructed at the southwest corner of 83rd Street and 35th Avenue. In the 1920s the parish began a building campaign to erect a new church and other related facilities, and it continued to augment the complex over the next four decades.

In 1927 plans were filed for a proposed Saint Joan of Arc Cathedral (NB 5442-1927) to be built on the site of the original wooden church. The proposed cathedral was designed in a French neo-Gothic style by Brooklyn architects Murphy & Lehman. However, permission to build the cathedral never materialized, and only the basement level of the building was executed. (The original basement is not visible on the exterior, although it is partially visible through grilles set in the base of the exterior walls of the church building.) In 1941, local architect W.A. Schlusing unveiled plans for a neo-Romanesque style church, but the plans were not filed until 1949. The new church was completed in 1951. (The church bears a cornerstone with the dates "1928-1950.")

The brick and stone church, which occupies the southwest corner of 35th Avenue and 83rd Street, is neo-Romanesque in style. The church is boldly massed with steeply pitched gables, a large polygonal apse, and a tower at the rear. Romanesque-inspired details include the arcaded windows of the aisle and clerestory, corbel courses, brick buttresses, attached stone columns with elaborate capitals, and mosaic tympanums over the doors of the portal.

In 1926, the parish constructed a rectory to designs by Murphy & Lehman. The neo-Gothic brick rectory, located on the southeast corner of 35th Avenue and 82nd Street, has French-inspired chateausque details, including the arched stone door surround in a keyed stone enframement with a pointed top, the hipped slate roof, the dormers with cusped gables, and the roof finials.

In 1924, the parish constructed a school, consisting of one story and a basement, which was enlarged in the next decade. (The building bears a cornerstone with the date, "MDCCCXXIV [1924].") In 1928, plans were filed to add two stories and a mansard to the school building, but this scheme was dropped the following year. In 1936, however, architect Henry V. Murphy filed plans for a two-story addition to the existing school. The additional floors were completed in 1937. The school is located on the east side of 82nd Street, just south of the rectory at the 35th Avenue corner. Its design reflects a stylized neo-Gothic aesthetic. The facade has brick piers accented with stone coping, which are suggestive of buttresses. The tripartite window bays are likewise trimmed in stone. At the roofline is a stepped and pedimented parapet.

Henry Murphy also designed the convent, which was constructed in 1940-41 on 83rd Street, south of the church. The convent, like the school, has a stylized neo-Gothic facade of brick trimmed in stone. The facade is enlivened by the central door surround with its elaborate label lintel, keyed stone enframements with cusped spandrels at the bays above the entrance, patterned brick spandrels in flanking windows, and a parapet with battlements and a cartouche.

The last building to be constructed by the parish, the Ward Meehan Meeting Hall named in honor of the parish's first pastor, was built in 1960-61 from designs by LaPierre & Litchfield. The one-story International Style building, on 82nd Street south of the school, has a short facade facing the street and a long north facade extending into the block beyond an iron fence. The 82nd Street facade is brick and includes the metal-framed entrance. The north facade is characterized by contiguous windows set in vertical openings with extruded mullions.

Sources: Karatzas, 106-107.
Jackson Heights News 25, no. 14 (July 25, 1941), 1.
Queens Department of Buildings, Plans and Drawings.
Sanborn Maps, 1940, 1961.



Saint Joan of Arc R.C. Church Complex

Block 1456 Lots 1 & 4

82-00 35th Avenue

35-02 83rd Street

35-07 82nd Street

35-29 82nd Street

35-24 83rd Street

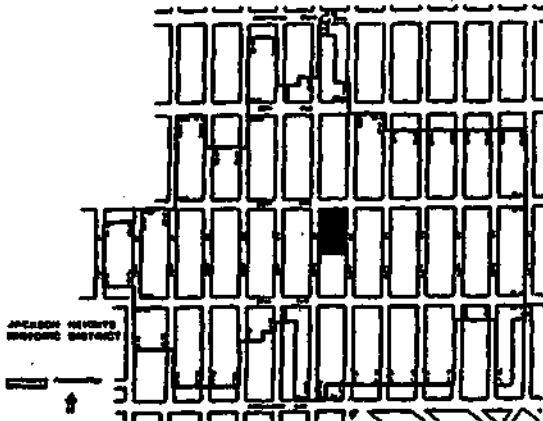
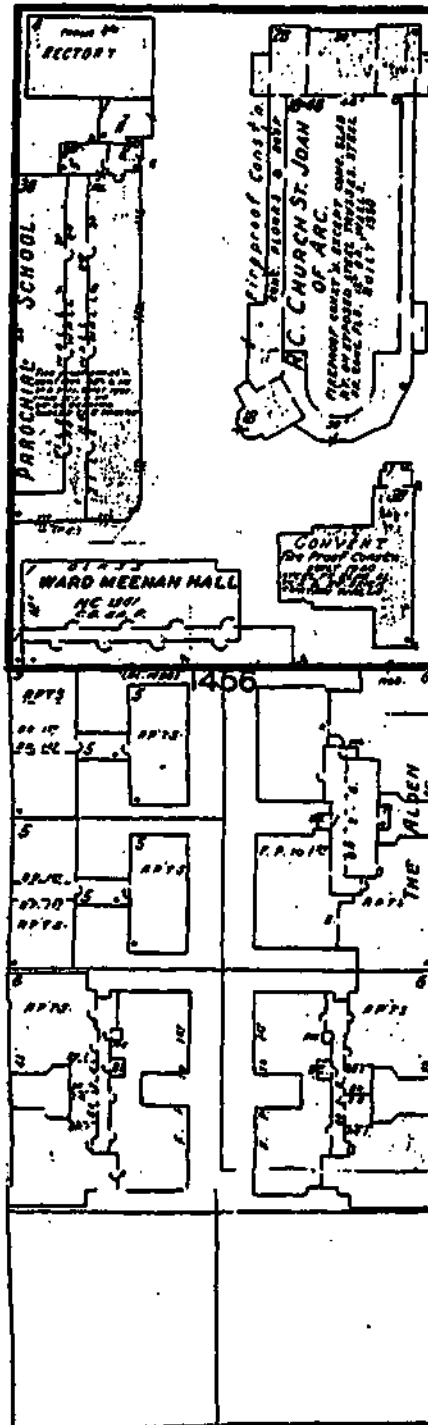

35th Avenue between 83rd Street and 84th Street (South Side)

FILLMORE HALL

83-02—83-12 35th Avenue (a/k/a 35-01—35-15 83rd Street and 35-02—35-16 84th Street)

Block/lots: 1457/1, 6

Type: Apartment Building
Stories: 6 with basement
Style: Neo-Romanesque

Date: 1930 [NB 1385-1930]
Architect: E. Adelson
Developer: Four Hundred Realty Corp.

Built in 1930 to designs by E. Adelson, Fillmore Hall is characteristic of the later phase of apartment house development in the historic district. The particularly large structure is planned with lightcourts and courtyards which break up the mass into a series of smaller units with multiple entrances. This scheme represents a planning solution akin to that of the earlier garden apartment complexes. The plan forms an "H"-shaped footprint; on 35th Avenue there is a deeply recessed court containing the building's main entrance and the street frontages represent the long sides of the "H," each of which is divided into three smaller units by lightcourts. Secondary entrances are located in the lightcourts.

The brick six-story-and-basement building is neo-Romanesque in style, exemplified by the projecting main entrance portico with a stone enframement of paired twisted columns, an entablature with carved floral details, stone urns, and a tile roof. Other neo-Romanesque elements include corner towers, brick diaperwork, stone and brick band courses, corbel tables, and Spanish tile roofs. All of the courts are framed at the sidewalk by brick garden walls with decorative stone urns. The southernmost lightcourt on each of the side streets contains a secondary entrance with iron-and-glass doors set in round-arched openings. Many of the original four-over-four and six-over-six double-hung wood sash remain.

The original rooftop loggias have been removed (their location is indicated by raised brick posts and railings along the parapet walls). Chain-link fences have been added around the perimeter gardens. Some of the urns are missing from the garden walls.

35th Avenue between 84th Street and 85th Street (South Side)

THE BELVEDERE

84-02—84-12 35th Avenue (a/k/a 35-01 84th Street and 35-02 85th Street)

Block/lot: 1458/1

Type: Apartment Building
Stories: 6 with basement
Style: Neo-Romanesque

Date: 1936-37 [NB 4913-1936]
Architect: Joshua Tabatchnik
Developer: Fillmore Gardens

Built in 1936-37 to designs by Joshua Tabatchnik, the Belvedere is among the later apartment buildings erected in the historic district. Typical of that phase of development, the large building occupies an end-block site on 35th Avenue and is planned with a shallow central entrance pavilion and two recessed lightcourts on the avenue front and one lightcourt at each of the street fronts on 84th and 85th streets.

Faced in brick with stone trim, the building is neo-Romanesque in style. The six-story-and-basement structure is complex in its massing, having towers of various forms, gabled end bays, and projecting angled bays in the lightcourts. The square towers flanking the entrance pavilion on 35th Avenue are pierced by arcaded loggias and topped with red tile roofs on bracketed eaves. Polygonal towers and smaller square towers flank the lightcourts on the side streets. The arcaded entrance porch, with its tiled

roof, shelters an arched stone doorway containing glass double-doors with iron grilles. Other elements of Romanesque inspiration include round-arched windows in stone enframements with engaged colonnettes, stone balconettes, patterned brickwork, corbels, and corner quoins.

The small rear yard, partly visible from the street, is now part of the common garden shared with the two buildings to the south on 84th and 85th Streets, **Belvedere Gardens (West and East)**.

35th Avenue between 85th Street and 86th Street (South Side)

85-02 35th Avenue

See: 35-01—35-51 85th Street

35th Avenue between 86th Street and 87th Street (South Side)

QUEEN VICTORIA APARTMENTS

86-02—86-06 35th Avenue (a/k/a 35-01 86th Street and 35-02 87th Street)

Block/lot: 1460/1

Type: Apartment Building
Stories: 6 with basement
Style: Moderne (Post-World War II)

Date: 1950-51 [NB 457-1950]
Architect: Hyman I. Feldman
Owners: Joseph Gerlo; Charles S. Freeman

Designed by Hyman I. Feldman and built in 1950-51, the six-story-and-basement Queen Victoria Apartments is one of several apartment buildings constructed in the post-World War II era of development in Jackson Heights. Continuing the trend of the pre-War years, it is a large building on an end-block site and is planned with a broad recessed entrance court at the center of the avenue front and lightcourts at the street fronts. The building is very similar to the **Queen Elizabeth Apartments**, located on the north side of 35th Avenue one block to the west, which was designed by Feldman for the same developers and built at roughly the same time. A driveway leads from the rear of the building to a basement garage. The entrance court is landscaped and there are small gardens surrounding the building.

A late interpretation of the Moderne style, the brick building is distinguished by the horizontal expression of the brick banding on all facades and by the geometric header and stretcher brick patterning around the entrance. The double-leaf doors have square windows and are topped by a transom. Some of the original three-over-three windows with horizontal muntins survive.

35th Avenue between 87th Street and 88th Street (South Side)

87-02 35th Avenue

See: 35-01—35-05 87th Street

37TH AVENUE — North Side

37th Avenue between 77th Street and 78th Street (North Side)

77-01—77-19 37th Avenue (a/k/a 35-57A—35-59 77th Street and 35-58A—35-60 78th Street)
Block/lot: 1277/36

Type: Commercial Building
Stories: 1
Style: Neo-Georgian

Date: 1937 [NB 1397-1937]
Architect: Lenz & Berger
Developer: Apeco Realty Co.

Built in 1937 to designs by Lenz & Berger, this block-long one-story commercial building is characteristic of commercial development along 37th Avenue within the district. Featuring a facade in the neo-Georgian style, it shows how the commercial thoroughfare was planned to complement and integrate with the surrounding residential neighborhood. Georgian-inspired elements include the paneled brick parapet, enlivened by four triangular pediments with blind oculi; bricks laid to resemble quoins; and cast-stone coping and urns at the roofline.

There are storefronts on the sides of the building fronting 77th and 78th streets as well as the avenue. Below the stone stringcourse marking the fascia, most of which is obscured by signage, all of the historic storefronts have been replaced. A few of the brick piers between the storefront openings are visible.

37th Avenue between 78th Street and 79th Street (North Side)

78-01—78-15 37th Avenue (a/k/a 35-63 78th Street)
Block/lot: 1278/44

Type: Commercial Building
Stories: 1
Style: Moderne

Date: 1941 [NB 551-1941]
Architect: Oscar I. Silverstone
Developer: Boro Heights Corp.

This one-story building, designed in the Moderne style by Oscar I. Silverstone, is characteristic of the commercial development of 37th Avenue in the 1940s. Located at the northeast corner of the avenue and 78th Street, the building has a stone facade on the avenue; this facing continues at the chamfered corner and on a portion of the 78th Street elevation. The remainder of that elevation is brick. The original Moderne design survives in the projecting scalloped stone coping, the fluted and stepped stone pediment atop the angled corner bay, and the stone fascia of two rope-like moldings. Storefronts are located along 37th Avenue and the corner storefront wraps around to 78th Street; there are additional storefronts on the side street elevation. Below the fascia most of the storefronts have been replaced or obscured by signage, fixed awnings, and security gates. An historic Carrara glass storefront sign with painted lettering survives at 78-03--78-05 37th Avenue.

37th Avenue between 78th Street and 79th Street (North Side)

(Former) QUEENSBORO CORPORATION HEADQUARTERS

78-17—78-27 37th Avenue (a/k/a 35-64 79th Street)

Block/lot: 1278/38

Type: Commercial Building

Stories: 2

Style: Neo-Georgian

Date: 1947 [NB 433-1946]

Architect: Andrew J. Thomas

Developer: Queensboro Corp.

The two-story headquarters building of the Queensboro Corporation was built in 1947 to designs by Andrew J. Thomas. It was the last of Thomas's many commissions from the corporation, which spanned nearly thirty years. This was Queensboro's second headquarters in Jackson Heights, the first being the neo-Tudor structure at the southwest corner of 82nd Street and 37th Avenue, built in 1928-29 to designs by Morrell Smith.

The brick building (now painted) was designed to contain offices, as well as stores along 37th Avenue. The neo-Georgian elements of the building's design include gabled roofs containing oculi in the pediments, six-over-six double-hung wood windows with wood slat shutters, and stone door surrounds which have a broken pediment above the 79th Street entrance, a segmental pediment above the principal 37th Avenue entrance, and a molded arch at the western entrance on the avenue. A brick fascia course separates the stories. Storefronts are located along 37th Avenue and the corner storefront wraps around to 79th Street for one bay. All of the historic storefronts have been replaced or obscured by signage and security gates; however, the original configuration of the openings survives. Other noticeable alterations include the removal of shutters from the second-story windows on 37th Avenue.

Source: Karatzas, 156.

37th Avenue between 79th Street and 80th Street (North Side)

VERONA COURT

79-01—79-27 37th Avenue (a/k/a 35-63 79th Street and 35-64 80th Street)

Block/lot: 1279/35

Type: Apartment Building

Stories: 6

Style: Neo-Romanesque

Date: 1929 [NB 847-1929]

Architect: E. Adelson

Developer: Resig Construction Corp.

Built in 1929 to designs by E. Adelson, the six-story Verona Court is a large building occupying an end-block site on 37th Avenue and its street frontages on 79th and 80th streets are each divided into two sections by a recessed lightcourt with an entrance; the avenue frontage is flush with the lot line and features storefronts at street level.

The design of the building is largely of Romanesque inspiration. A variety of decorative brickwork patterns are used to articulate the facades. The one-story base is defined by broad horizontal bands suggestive of Spanish *mudejar* motifs. Both horizontal and vertical brick patterns relieve the upper facades, the projecting brickwork suggesting pilasters. Diaperwork arches at the roofline further divide the facade into large sections. Other features include iron balconies; decorative brick window aprons; and projecting pitch-roofed entrance pavilions containing arched doorways framed by spiraled columns.

Similar twisted colonettes frame the flanking windows. The original glass doors with elaborate iron grillework and transoms survive.

Alterations to the building include the removal (sometime after 1986) of pitched tile-roof overhangs which were originally found on the sides of the roofline pediments. The tiles have been removed from the pitched roofs of the entrance pavilions.

Storefronts are located along 37th Avenue and wrap around to the side streets for one bay at each corner. Almost all the original storefronts have been replaced, although some historic storefront elements do survive, including courses of brick immediately below the fascia, seen above the signage of most stores; banded brickwork between some openings; the corner brickwork flanking the westernmost storefront; and brick bulkheads containing metal gratings below the show windows of the westernmost store at No. 79-01 and at the eastern half of the storefront at No. 79-09-79-11.

37th Avenue between 80th Street and 81st Street (North Side)

RAVENNA COURT

80-01-80-29 37th Avenue (a/k/a 35-63 80th Street and 35-64 81st Street)

Block/lot: 1280/38

Type: Apartment Building
Stories: 6
Style: Neo-Romanesque

Date: 1928-29 [NB 4154-1928]
Architect: Rogers & Haneman
Developer: Jackson Heights Apt. Corp.

Built in 1928-29 to designs by Rogers & Haneman, the six-story Ravenna Court is a large building occupying an end-block site on 37th Avenue and its street frontages on 80th and 81st streets are each divided into two sections by a recessed lightcourt with an entrance; the avenue frontage is flush with the lot line and features storefronts at street level.

The design of Ravenna Court is of Romanesque inspiration. The facades are enlivened with a variety of decorative brick patterns, including diaperwork, corbeling, and blind arcades, which are used to organize the facades. A broad horizontal frieze of raised brick defines the one-story base. At the roofline, a broad pediment is centered above the long avenue facade and open loggias with peaked roofs crown four corner towers; the parapets have pitched tops. The entrance in each of the recessed courts is articulated by a projecting pedimented surround with a pitched tile roof, pilasters, and a terra-cotta tympanum, and is flanked by terra-cotta rosettes. Sloping brick walls topped by heraldic stone lions front the entrance courts at the sidewalk.

Some of the original six-over-six double-hung wood sash windows remain. Alterations to the building include the removal of roof tiles, the replacement of entry doors and windows, and the addition of chain-link fences within the entry courts. Storefronts are located along 37th Avenue and wrap around to the side streets for one bay at each corner. Almost all the original storefronts have been replaced, although some historic storefront elements survive, including header courses at the fascia, brick piers between the openings (especially visible at the eastern corner), and an historic storefront with a marble bulkhead and a recessed door flanked by show windows (at 80-21 37th Avenue). The metal basement doors at the sidewalk may be original.

37th Avenue between 81st Street and 82nd Street (North Side)

81-01—81-19 37th Avenue (a/k/a 35-59—35-61 81st Street and 35-60 82nd Street)
Block/lots: 1281/43 and 38

Type: Commercial Building
Stories: 3
Style: Modern

Date: altered 1985-91*
Architect: Leo D. Fakler [1985];
Paul Mok [1988]
Developer: 188-17 Liberty Avenue
Corp. [1985]; Carlo
Cinaganelli [1988]

*Tax Map Block/Lot: 1281/38 — ALT 571-1985

*Tax Map Block/Lot: 1281/43 — ALT 1773-1988

Rebuilt between 1985 and 1991, the three-story A & C Department Store occupies the site of two groups of earlier one-story stores. One group of stores was built in 1918 (architect unknown) at the major commercial intersection in the district, 82nd Street and 37th Avenue, and later replaced in 1949-50 by a larger building with stores and offices, designed by L. Shulman. That building was then remodeled to its current state beginning in 1985, and extended in 1988 to incorporate the other group of similar one-story stores on the corner of 81st Street, originally designed in 1937 by Horace Ginsbern.

The building still occupies two tax lots, and comprises the full blockfront of 37th Avenue between 81st and 82nd Streets. The facade is cast-concrete and has horizontal bands of glazed brick; the storefronts are glass and metal; and a metal band wraps around the roofline. Storefronts are located along 37th Avenue and 82nd Street; there are no storefronts on 81st Street.

37th Avenue between 82nd Street and 83rd Street (North Side)

82-01—82-21 37th Avenue (a/k/a 35-64 83rd Street)
Block/lots: 1456/41 and 35

Type: Office Building and shopping arcade
Stories: 8
Style: Post-Modern

Date: 1986-94
Architect: Fakler/Eliason Assoc.
Developer: Carlo Cinganello

Until the 1980s, this site was occupied by a one-story commercial building containing storefronts that was built in 1937 to designs by J.H. Barry. The storefronts rose to half-timbered Tudor gables, and a small tower marked the corner. It was one of a cluster of neo-Tudor buildings marking the district's main commercial intersection at 37th Avenue and 82nd Street (surviving examples include **English Gables**, the (former) **Queensboro Corporation Headquarters**, **82-02-82-10 37th Avenue**, and **37-11-37-39 82nd Street**).

The stores were demolished in the late 1980s. Under construction is an eight-story pavilioned office building, set back from a two-story shopping arcade. The structure, faced in red brick, spans the blockfront between 82nd Street and 83rd Street and extends back onto the street frontages for 100 feet.

37th Avenue between 83rd Street and 84th Street (North Side)

GEORGIAN HALL

83-01—83-27 37th Avenue (a/k/a 35-61 83rd Street and 35-64 84th Street)

Block/lot: 1457/34

Type: Apartment Building

Stories: 6

Style: Neo-Georgian

Date: 1930-31 [NB 1386-1930]

Architect: E. Adelson

Developer: Queensboro Investing Co.

Built in 1930-31 to designs by E. Adelson, the six-story Georgian Hall is a large building occupying an end-block site on 37th Avenue. Its street frontages on 83rd and 84th streets are each divided into two sections by a recessed lightcourt with an entrance; the avenue frontage is set back behind a one-story commercial wing containing storefronts which is flush with the lot line.

The building has red brick facades with white stone trim and is neo-Georgian in style. Elements of that style include multi-story brick pilasters topped by stone entablatures and brick pediments with swags; stone bandcourses and brickwork suggestive of quoins; parapet balustrades with urns at the roofline and atop the storefront projection; stone entrance surrounds with broken scrolled pediments; multi-pane glass double-doors with fanlight transoms; and courtyard walls with balustrades. The storefront at each end of the projection wraps around the corner for one bay. Surviving storefront elements below the fascia include brick piers between the openings and several examples of the original storefront configuration of a door recessed between double shop windows. Noteworthy examples include No. 83-27 and No. 83-23 which is particularly intact, retaining its original marble bulkhead and metal framing. Roll-down security gates and applied signage obscure some elements of historic storefront fabric.

37th Avenue between 84th Street and 85th Street (North Side)

84-01—84-09 37th Avenue and 35-59—35-67 84th Street

Block/lot: 1458/40

Type: Commercial Building

Stories: 1

Style: Neo-Tudor

Date: 1940 [NB 648-1940]

Architect: G. Salemi

Developer: Pallante Holding Corp.

This one-story commercial building, designed by G. Salemi, is characteristic of the commercial development of 37th Avenue in the 1940s. The neo-Tudor style of the building complements much of the commercial and residential architecture of the neighborhood. Located at the northeast corner of the avenue and 84th Street, the brick building has a polygonal corner bay, gables with oculi (two on the avenue and one on the side street), and a pitched slate roof. Storefronts are located along 37th Avenue and the corner storefront wraps around to 84th Street for one bay; there are additional storefronts on the side street elevation. Below the fascia most of the storefronts have been replaced or obscured by signage, fixed awnings, and security gates.

37th Avenue between 84th Street and 85th Street (North Side)

84-11—84-23 37th Avenue
Block/lot: 1458/35

Type: Commercial Building
Stories: 1
Style: Moderne

Date: 1945-46 [NB 1666-1945]
Architect: Boris Dorfman
Developer: Polk Eighty Fifth Corp.

This one-story commercial building, designed by Boris Dorfman in the Moderne style, is characteristic of the commercial development of 37th Avenue in the 1940s and complements much of the architecture of the neighborhood. Located at the northwest corner of the avenue and 85th Street, the brick building has a curved corner bay, a stepped parapet with both smooth and fluted coping, and vertical stretcher courses of brick. Storefronts are located along 37th Avenue and the corner storefront wraps around to the 85th Street elevation; in addition, the brick side street elevation has four window openings with grilles and a bricked-in door opening. Below the fascia most of the storefronts have been replaced or obscured by signage, fixed awnings, and security gates.

37th Avenue between 85th Street and 86th Street (North Side)

85-01—85-13 37th Avenue
See: 35-65 85th Street

37th Avenue between 85th Street and 86th Street (North Side)

85-15—85-25 37th Avenue
Block/lot: 1459/35

Type: Commercial Building
Stories: 1
Style: Moderne (Post-World War II)

Date: c.1950 [Sanborn Map]
Architect: undetermined
Developer: undetermined

This one-story commercial building, constructed c. 1950, is characteristic of the commercial development of 37th Avenue in the post-World War II era. Located at the northwest corner of the avenue and 86th Street, the building has a tapestry brick facade with cast-stone trim. The Moderne design is evident in the curved corner bay, the striated banding with bezants, and the stepped parapet with coping. Below the fascia most of the storefronts have been replaced or obscured by signage, fixed awnings, and security gates. The storefront in the curved bay (No. 85-25), which wraps around to the side street, retains elements of its historic configuration. The remainder of the 86th Street elevation is brick.

37th Avenue between 86th Street and 87th Street (North Side)

86-01—86-13 37th Avenue
See: 35-65 86th Street

37th Avenue between 86th Street and 87th Street (North Side)

YOUNG ISRAEL OF JACKSON HEIGHTS

86-15—86-29 37th Avenue
Block/lot: 1460/34

Type: Commercial Building
(converted to religious use)
Stories: 1

Date: 1951 [NB 9784-1950]
Architect: Jack Fein
Developer: Polk Stores Corp.

Completed in 1951 to designs by Jack Fein, this one-story brick and stucco building was constructed for commercial use and later converted into a synagogue and school. The entrance is on 37th Avenue. Its facades have horizontal bays of jalousie windows.

37th Avenue between 87th Street and 88th Street (North Side)

THE CRESTON ARMS

87-01—87-11 37th Avenue
Block/lot: 1461/35

Type: Apartment Building
Stories: 6 with basement
Style: Moderne (Post-World War II)

Date: 1954-55 [NB 965-1954]
Architect: Seelig & Finkelstein
Developer: Barlut Building Corp.

Designed by Seelig & Finkelstein and built in 1954-55, the six-story-and-basement Creston Arms is one of several apartment buildings constructed in the post-World War II era of development in Jackson Heights. Continuing the trend of the pre-War years, it is a large building on an end-block site and is planned with two deep lightcourts which break the avenue front into three sections, that at the center being the widest. Each section has a shallow recess containing a fire escape; the central recess contains the main entrance. Secondary entrances are located in each section. A vehicular door in the 87th Street facade leads to a basement garage.

A late interpretation of the Moderne style, the brick building is distinguished by the horizontal expression of the continuous cast-stone lintel and sill courses. The main entrance has a polished black granite surround containing plate-glass doors and topped by a metal-trimmed marquee.

37TH AVENUE — South Side

37th Avenue between 77th Street and 78th Street (South Side)

PUBLIC SCHOOL 69

77-02 37th Avenue (a/k/a 37-01 77th Street and 37-02 78th Street)

Block/lot: 1288/1

Type: School
Stories: 5
Style: Neo-Tudor

Date: 1922-24 [NB 8511-1922]; 1993
Architect: C.B.J. Snyder; Urbahn Associates
Owner: City of New York, Board of Education

P.S. 69, a five-story brick school building with a two-story rear wing, was built in 1922-24 to serve the growing Jackson Heights community. As Superintendent of Buildings for the New York City Board of Education, the school's architect, C.B.J. Snyder, was responsible for the design of schools throughout the five boroughs from 1898 until his retirement in 1923. The school faces 37th Avenue between 77th and 78th streets and is situated on a large lot that takes up most of the northern half of the block. Like a great many of Snyder's schools from the period, P.S. 69 is neo-Tudor in style; this architectural treatment is particularly harmonious with the many Tudor-inspired residential and commercial buildings elsewhere in the historic district.

The brick facades, rising from a stone water table, are articulated with large bays of nine-over-nine double-hung windows in groups of four. The 37th Avenue facade is massed with end pavilions flanking a recessed central section. The projecting two-story brick and stone entry pavilion is composed of a Tudor-arched portal with paneled doors, glazed transoms, and decorated terra-cotta spandrels, and a second-story bay of pointed-arched windows surmounted by a pediment. Other ornamental details include label lintels, terra-cotta spandrel plaques, and a crenelated roof parapet with stone coping. The side entrances are located in simpler projections with crenelated parapets. A tall chimney joins the unadorned rear wing.

At the rear of the building, on the 77th Street side of the lot, construction began in 1993 on a large addition, faced in red brick (designed by Urbahn Associates). There is a one-story classroom structure on the 78th Street side of the lot.

Source: Karatzas, 103-104; architect's rendering.

37th Avenue between 78th Street and 79th Street (South Side)

JACKSON HEIGHTS POST OFFICE

78-02 37th Avenue (a/k/a 37-01 78th Street and 37-02 79th Street)

Block/lot: 1289/1

Type: Post Office
Stories: 1
Style: Neo-Georgian

Date: 1936-37; additions, 1964
Architect: Benjamin C. Flournoy
Owner: U.S. Treasury Department

Built as the Jackson Heights Station of the Flushing Post Office, this post office building was constructed in 1936-37 to designs by Benjamin C. Flournoy, a consulting architect commissioned by the Office of the Supervising Architect of the Treasury. Its construction was part of the public works projects initiated by the U.S. government during the Depression of the 1930s. The post office occupies the blockfront on

the south side of 37th Avenue between 78th and 79th Streets. An addition to the east side, encompassing the four easternmost bays on the main (37th Avenue) facade, and most of the rear portions of the building are additions of 1964.

Designed in the neo-Georgian style, the building has facades of red brick with white trim and harmonizes with the many neo-Georgian residential buildings in the historic district. Georgian-inspired elements of the design include the symmetrical massing of the original section, with four granite steps leading to a temple-fronted entrance pavilion, consisting of four broad, brick pilasters supporting a limestone entablature and triangular pediment. The carved wood door surround is composed of flanking colonnettes, pilasters, and an entablature below an arched fanlight with a large metal statue of an eagle perched in front of it. Other notable details include horizontal stone courses defining the entablature and water table; and original twelve-over-twelve double-hung windows with stone lintels and sills. Along 37th Avenue at the west end runs a brick wall which shields the loading area on 78th Street. The 1964 addition at the east end continues the design of the original building; it includes a secondary entrance with a paneled door in a classical enframingent.

Source: "United States Post Offices in New York State, 1858-1943, Thematic Resources: United States Post Office, Jackson Heights Station, Flushing, N.Y.," form prepared by Larry G. Gobrecht, National Register and Survey Coordinator, New York State Office of Parks, Recreation, and Historic Preservation (Nov., 1986).

37th Avenue between 79th Street and 80th Street (South Side)

ROBERT MORRIS APARTMENTS

79-02—79-28 37th Avenue (a/k/a 37-01—37-05 79th Street and 37-02—37-06 80th Street)

Block/lot: 1290/1

Type: Apartment Building
Stories: 6
Style: Neo-Georgian

Date: 1929 [NB 674-1929]
Architect: E. Adelson
Developer: Remow Builders

Built in 1929 to designs by E. Adelson, the six-story Robert Morris Apartments is a large building occupying an end-block site on 37th Avenue and its street frontages on 79th and 80th streets are each divided into two sections by a recessed lightcourt with an entrance; the avenue frontage is flush with the lot line and features storefronts at street level.

The building is neo-Georgian in style. Elements of the building's design which are characteristic of that style include the paired colossal brick pilasters surmounted by pediments at the roofline; the molded cornice and roofline balustrade; arched stone window heads with swag details; the dentiled brick band course at the first story; the low brick and cast-stone walls at the court entrances; and the classically-inspired entry surrounds. The original multi-pane transoms survive above the replacement doors in both courts.

Storefronts are located along 37th Avenue and wrap around to the side streets for one bay at each corner. Almost all the original storefronts have been replaced, although some historic storefront elements do survive, including transoms with anthemion cresting (visible at Nos. 79-08--79-10, 79-14, and 79-24); the configuration of a recessed shop door between two show windows (four storefronts extant); and brick piers between the storefront openings. Other elements may be extant behind more recent materials and signage.

37th Avenue between 80th Street and 81st Street (South Side)

80-02—80-28 37th Avenue (a/k/a 37-01—37-05 80th Street and 37-02 81st Street)
Block/lots: 1291/1,6

Type: Apartment Building
Stories: 6
Style: Neo-Romanesque

Date: 1928-29 [NB 6016-1928]
Architect: Kavy & Kavovitt
Developer: Hayes Construction Corp.

Built in 1928-29 to designs by Kavy & Kavovitt, this large six-story building occupies an end-block site on 37th Avenue and its street frontages on 80th and 81st streets are each divided into two sections by a recessed lightcourt with an entrance. The avenue frontage is also bisected by a recessed lightcourt above the ground story; flush with the lot line are storefronts at street level.

The design of the building is largely of Romanesque inspiration. Decorative brickwork patterns are used to articulate the facades, including soldier courses at the first story and the water table and arched corbel tables at the roofline. At the roof are corner towers with open loggias and pitch-roofed parapets. In the court of each street facade is a brick entrance pavilion with a segmentally-arched opening, a pitched roof, and flanking niches. On 81st Street, the original metal and glass double doors with a fanlight transom survive, and the flanking metal lamps also appear to be original. Low brick walls with piers front each entrance court at the sidewalk. The 80th Street entrance doors have been replaced and the roofs above the entrances have been resurfaced.

Storefronts are located along 37th Avenue and wrap around to the side streets for one bay at each corner; in addition, a commercial space (with the address of 37-05 80th Street) has been inserted in the southern portion of the 80th Street facade. The original storefronts have been replaced, although some historic storefront elements survive behind more recent signage and storefront infill, including some transoms, the brick fascia, and some of the brick piers defining the openings.

37th Avenue between 81st Street and 82nd Street (South Side)

81-02 (a/k/a 37-01—37-09 81st Street)—81-10 37th Avenue
Block/lots: 1292/1, 2, 4, 5, 104

81-02 37th Avenue (a/k/a
37-01—37-09 81st Street) [1292/1]
81-04 37th Avenue [1292/2]

81-06 37th Avenue [1292/4]
81-08 37th Avenue [1292/104]
81-10 37th Avenue [1292/5]

Type: Apartments with stores (5 buildings)
Stories: 3
Style: Post-World War I decorative brick

Date: 1922-23*
Architect: J. Lubrott
Developer: Polk Construction Co.

*No. 81-02A--81-02B 37th Avenue — NB 14023-1922

*Nos. 81-04, 81-06, 81-08, 81-10 37th Avenue — NB 14024-1922

Built in 1922-23 to designs by J. Lubrott, this group of five three-story brick buildings has apartments at the upper stories and ground-level storefronts. The 37th Avenue street front includes five stores. The corner storefront of No. 81-02 wraps around for one bay on 81st Street; in addition, the 81st Street elevation has the building entrance and four shops, three of which are located in an adjoining one-story brick structure to the south of the entrance.

The facades of the buildings display an imaginative use of decorative polychromatic brickwork and cast-stone trim. The various brick patterns include zigzag, basketweave, checkerboard, and soldier coursing. The parapets have curved pediments with stone plaques. This type of design using decorative brick and cast-stone patterning was very popular in the first two decades of this century.

The stone entrance surround on 81st Street (bearing the address 37-03) includes a wood door flanked by colonnettes, sidelights and a wide transom. Many of the original multi-paned windows survive, including the tripartite pair at the second-story corner office at No. 81-02. The window openings have been enlarged at No. 81-08. All of the original storefronts have been replaced.

37th Avenue between 81st Street and 82nd Street (South Side)

(former) QUEENSBORO CORPORATION HEADQUARTERS

81-14—81-28 37th Avenue (a/k/a 37-02—37-10 82nd Street)

Block/lot: 1292/6

Type: Commercial Building

Stories: 3

Style: Neo-Tudor

Date: 1928-29 [NB 6008-1928]

Architect: Morrell Smith

Developer: Queensboro Corp.

Built 1928-29 to designs by Morrell Smith, the (former) Queensboro Corporation Headquarters is one of a cluster of neo-Tudor commercial buildings which survive at or near the intersection of 82nd Street and 37th Avenue, the historic district's two commercial thoroughfares. The other structures are the **English Gables** abutting it to the south, and the stores at **82-02--82-10 37th Avenue** and **37-11--37-39 82nd Street**, on the east side of 82nd Street.

After actively developing Jackson Heights for over a decade, the Queensboro Corporation relocated most of its operations from 14 East 41st Street in Manhattan to this structure, which was to be its first headquarters in the neighborhood. (The corporation's second office building was erected in 1947 to designs by Andrew J. Thomas at the northwest corner of 79th Street and 37th Avenue.) When the building opened, 250 employees occupied all three floors.

The building extends 100 feet along each of the major commercial thoroughfares. Above a one-story stone base, the brick upper facades are enlivened with stone quoins and stucco and wood half-timbering. The building is massed with four projecting gables, including one at the angled corner, and crowned with a pitched slate roof. Tudor-inspired elements of the design include double-height oriels; stone rams' heads, niches, and quatrefoils; and multi-pane casement windows with transoms.

An early illustration of the building indicates that originally the building had two storefronts at the southern end of the 82nd Street facade; the current storefronts in those openings are later replacements and signage obscures stonework above the openings. The Tudor-arched entryway on 82nd Street is intact, and the corner and avenue entrances retain the original drip moldings above the openings. It appears that the remainder of the ground-story openings (on 37th Avenue and 82nd Street), which originally may have had multi-pane casements and now contain plate glass windows in metal frames, have been lengthened from their original height.

Source: Karatzas, 73-74; illus.

37th Avenue between 82nd Street and 83rd Street (South Side)

82-02—82-10 37th Avenue (a/k/a 37-01—37-09 82nd Street)
Block/lot: 1470/1

Type: Commercial Building
Stories: 1
Style: Neo-Tudor

Date: 1921-22 [NB 12235-1921]
Architect: Seelig & Finkelstein
Developer: M. Beinstock

Built in 1921-22 to designs by Seelig & Finkelstein, this is among the earliest of the commercial buildings constructed within the historic district and one of a cluster of neo-Tudor structures which survive at or near the intersection of 82nd Street and 37th Avenue, the district's two commercial thoroughfares. The other structures are the stores at **37-11—37-39 82nd Street** abutting it to the south, and the (former) **Queensboro Corporation Headquarters** and **English Gables** on the west side of 82nd Street. The firm of Seelig & Finkelstein was also responsible for a number of apartment buildings in the historic district.

Faced in stone of random ashlar in various colors, the one-story building has long facades with storefronts on both 82nd Street and 37th Avenue, meeting at a chamfered corner with a square tower. The tower is adorned with an open scroll bearing a fleur-de-lis. The parapets are accented with gridded panels. The eastern portion of the avenue facade is topped by a lower brick parapet with stone plaques and stone coping.

Below the fascia all of the storefronts have been replaced. The upper facade is partly obscured by signage and fixed awnings.

37th Avenue between 82nd Street and 83rd Street (South Side)

82-12—82-20 37th Avenue (a/k/a 37-02—37-10 83rd Street) and 37-08—37-10 83rd Street
Block/lot: 1470/6

Type: Commercial Building
Stories: 1
Style: Vernacular

Date: 1920 [NB 4629-1920]
Architect: George H. Wells
Developer: Queensboro Corp.

Built in 1920 to designs by George H. Wells, this is the first commercial building to be erected along 37th Avenue within the historic district. Architect George Wells is best known for his early and innovative designs for garden apartments in Jackson Heights.

Storefronts are located along 37th Avenue and the corner storefront wraps around to 83rd Street for one bay; there is another storefront at the southern end of the side street elevation. A brick parapet with stone coping surmounts the storefronts. On 37th Avenue, there have been extensive alterations to storefronts, and much of the facade is obscured by signage and alterations. More of the original brick wall can be seen on the 83rd Street facade, which also retains a projecting eave with a Spanish tile roof.

37th Avenue between 83rd Street and 84th Street (South Side)

83-02—83-14A 37th Avenue (a/k/a 37-01—37-09 83rd Street)
Block/lot: 1471/1

Type: Commercial Building
Stories: 1
Style: Vernacular

Date: 1924 [NB 14895-1924]
Architect: M.A. Cantor
Developer: G.K. Construction Co.

Built in 1924 to designs by M.A. Cantor, this one-story commercial building is characteristic of early commercial development along 37th Avenue within the district. Designed with a pent roof of Spanish tile, a feature found on many residential buildings in Jackson Heights, this structure exemplifies how the commercial architecture of 37th Avenue was planned to complement and integrate with the surrounding residential neighborhood; for example, the **Spanish Gardens** complex immediately to the south, built at roughly the same time, incorporates Spanish tile parapets in its design. The original roof on the commercial structure is still visible along most of the 83rd Street facade and a portion of the avenue facade, where it is not obscured by signage and later alterations. Storefronts are located along both 37th Avenue and 83rd Street. Below the fascia all the storefronts have been replaced.

37th Avenue between 83rd Street and 84th Street (South Side)

83-14—83-22 37th Avenue (a/k/a 37-10 84th Street)
Block/lot: 1471/6

Type: Commercial Building
Stories: 1
Style: Neo-Tudor

Date: 1941 [NB 1346-1941]
Architect: Cohn Brothers
Developer: Harlem Queens Corp.

Built in 1941 to designs by Cohn Brothers, a firm which produced several apartment buildings in Jackson Heights, this one-story commercial building is characteristic of commercial development along 37th Avenue within the district. Featuring neo-Tudor elements in its design, it shows how the commercial thoroughfare was planned to complement and integrate with the surrounding residential neighborhood.

The building has a pitched slate roof punctuated by small gables. The westernmost gable on the 37th Avenue facade and the gable at the building's chamfered corner are half-timbered, while the others are brick-faced. Storefronts are located along 37th Avenue and the corner storefront wraps around to 84th Street for one bay. The 84th Street facade is brick trimmed with random quoins and features two gable ends, a chimney, keyed window openings (one of which is sealed), and a keyed door opening (sealed) surmounted by an oculus window. Below the fascia all of the storefronts on 37th Avenue have been replaced.

37th Avenue between 84th Street and 85th Street (South Side)

84-02—84-30 37th Avenue (a/k/a 37-01 84th Street and 37-02 85th Street)
Block/lot: 1472/1

Type: Commercial Building
Stories: 1
Style: Moderne (Post-World War II)

Date: 1947-48 [NB 4243-1946]
Architect: Shampán & Shampán
Developer: Fortieth Realty Corp.

This block-long one-story commercial building, built in 1947-48 and designed in the Moderne style by Shampman & Shampman, is characteristic of the commercial development of 37th Avenue in the 1940s. It is very similar to the building at **85-02--85-30 37th Avenue** located one block to the east, which was designed by the same firm and built at roughly the same time. The original Moderne design of the facade survives in the header brick bands, the simple stepped parapet with cast-stone coping, the cast-stone plaques at the raised sections of the parapets, and the cast-stone bands at the corners. Storefronts are located on 37th Avenue as well as on both side streets. Portions of the facade are obscured by large signs. Below the fascia almost all of the original storefront fabric has been replaced, although remnants of the original design, including a few bulkheads, survive.

37th Avenue between 85th Street and 86th Street (South Side)

85-02--85-30 37th Avenue (a/k/a 37-01 85th Street and 37-02 86th Street)
Block/lot 1473/1

Type: Commercial Building
Stories: 1
Style: Moderne (post-World War II)

Date: 1947 [NB 4246-1946]
Architect: Shampman & Shampman
Developer: Fortieth Realty Corp.

This block-long one-story commercial building, built in 1947 and designed in the Moderne style by Shampman & Shampman, is characteristic of the commercial development of 37th Avenue in the 1940s. It is very similar to the building at **84-02--85-30 37th Avenue** located one block to the west, which was designed by the same firm and built at roughly the same time. The original Moderne design of the facade survives in the header brick bands, the simple parapet with cast-stone coping, and the cast-stone bands at the corners and at the center of the avenue facade. Storefronts are located along 37th Avenue and wrap around to the side streets for one bay at each corner. Portions of the facade are obscured by large signs. Below the fascia almost all of the historic storefront fabric has been replaced, with the notable exception of a Carrara glass sign band with painted lettering located at the corner storefront (No. 85-30).

37th Avenue between 86th Street and 87th Street (South Side)

86-02--86-20 37th Avenue and 37-01--37-09 86th Street and 37-02--37-10 87th Street
Block/lot: 1474/1

Type: Commercial Building
Stories: 1
Style: Moderne (post-World War II)

Date: 1948-49 [NB 6337-1947]
Architect: Max Horn
Developer: Hanover & Morgenstein

This block-long one-story commercial building, built in 1948-49 and designed in the Moderne style by Max Horn, is characteristic of the commercial development of 37th Avenue in the 1940s. The original Moderne design of the facade survives in the curved corners at each end of the avenue facade and in the striated metallic banding at the parapet. At No. 86-02 the stepped profile of the curving parapet and the metallic molding which sets off the sign band remain visible. Storefronts are located along 37th Avenue and wrap around to the side streets for one bay at each corner. The brick facades on 86th and 87th streets have brick banding and are coped in stone. Portions of the facade are obscured by large signs and at No. 86-12 the front has been built up one story. Below the fascia the storefront alterations have been extensive.

37th Avenue between 87th Street and 88th Street (South Side)

SUSSEX HOUSE

87-02—87-10 37th Avenue (a/k/a 37-01—37-05 87th Street and 37-02 88th Street)

Block/lot: 1475/1

Type: Apartment Building

Stories: 7

Style: Moderne (Post-World War II)

Date: 1952-53 [NB 4337-1952]

Architect: Julius Fishkin

Developer: J. Friedland

Designed by Julius Fishkin and built in 1952-53, the seven-story Sussex House is one of several apartment buildings constructed in the post-World War II era of development in Jackson Heights. Continuing the trend of the pre-War years, it is a large building on an end-block site and is planned with three deep lightcourts which break the avenue front into four sections. The central court contains the main entrance. (There are no storefronts.) A vehicular door in the 87th Street facade leads to a basement garage.

A late interpretation of the Moderne style, the building is distinguished by the horizontal expression of subtle brick banding and by the contrasting verticality of abstracted brick piers rising from the base to the parapet. The main entrance has a white marble surround containing plate-glass doors and side walls.

ROOSEVELT AVENUE — North Side

Roosevelt Avenue between 81st Street and 82nd Street (North Side)

CORN EXCHANGE BANK/(now) Chemical Bank

81-11—81-19 Roosevelt Avenue (a/k/a 37-68—37-70 82nd Street)

Block/lot: 1292/42

Type: Bank
Stories: 2
Style: Modern Classical

Date: 1922-24 [NB 13788-1922]
Architect: Fellheimer & Wagner
Developer: Corn Exchange Bank

The two-story (former) Corn Exchange Bank, designed by Fellheimer & Wagner and built in 1922-24 at the southwest corner of 82nd Street and Roosevelt Avenue, is the only bank building designed as such within the Jackson Heights Historic District. Following a long tradition of classically-based bank architecture while drawing on an aesthetic trend of the 1920s, the stone-faced building has a modern design incorporating stylized classical details.

Above a granite water table, the stone facades are articulated by large window openings framed by piers and spandrels. The curved corner bay features a portico of Doric columns from which a metal entrance projects. Above, the windows of the curved bay are framed by pilasters with capitals bearing eagles in relief. The spandrels in the bays of the side facades have carved stone rondels with lions' heads. The pilasters flanking the bays are capped with carved panels displaying bundles of corn. A simple cornice crowns the facade. The paired and tripartite two-over-two, two-over-one, and one-over-one double-hung metal sash windows are original, as is the glazed transom above the entrance. The lower portion of the walls have been painted and signage has been added to the facade.

Roosevelt Avenue between 82nd Street and 83rd Street (North Side)

82-01 Roosevelt Avenue (a/k/a 37-61—37-67 82nd Street)

Block/lot: 1470/47

Type: Commercial Building
Stories: 2
Style: Post-World War I decorative brick

Date: 1922 [NB 7331-1922]
Architect: M.A. Cantor
Developer: Stores Construction Co.

Built in 1922 to designs by M.A. Cantor, this two-story commercial building occupies the northeast corner of Roosevelt Avenue and 82nd Street, adjacent to the elevated train tracks. The building is characteristic of early commercial development in the district. The building's two facades have decorative brickwork and large window openings. The long street facade and the narrow avenue facade are each marked by a triangular pediment at the parapet, decorated with ceramic tiles and a centrally-placed medallion motif. Both facades have storefronts at the ground story; the 82nd Street facade has a one-story storefront extension to the north. The fascia, mostly obscured by signage, consists of a brick and tile frieze with a geometric design (most visible at No. 37-67 82nd Street). All of the storefronts below the fascia have been replaced.

76TH STREET — East Side

76th Street between 35th Avenue and 37th Avenue (East Side)

HAWTHORNE COURT

35-13—35-55 76th Street and 35-14—35-56 77th Street

Block/lots: 1276/71, 67, 64, 60, 57, 53, 50, 12, 15, 19, 22, 26, 29, 33

35-13 76th Street [1276/71]
35-19 76th Street [1276/67]
35-27 76th Street [1276/64]
35-33 76th Street [1276/60]
35-41 76th Street [1276/57]
35-49 76th Street [1276/53]
35-55 76th Street [1276/50]

35-14 77th Street [1276/12]
35-20 77th Street [1276/15]
35-28 77th Street [1276/19]
35-34 77th Street [1276/22]
35-42 77th Street [1276/26]
35-50 77th Street [1276/29]
35-56 77th Street [1276/33]

Type: Garden Apartments (14 buildings)

Stories: 5

Style: Neo-Georgian

Date: 1921-22*

Architect: George H. Wells

Developer: Queensboro Apt., Inc.

*No. 35-13 76th Street — NB 7548-1921
*No. 35-19 76th Street — NB 7549-1921
*No. 35-27 76th Street — NB 7550-1921
*No. 35-33 76th Street — NB 7551-1921
*No. 35-41 76th Street — NB 7552-1921
*No. 35-49 76th Street — NB 7553-1921
*No. 35-55 76th Street — NB 7554-1921

*No. 35-14 77th Street — NB 7561-1921
*No. 35-20 77th Street — NB 7560-1921
*No. 35-28 77th Street — NB 7559-1921
*No. 35-34 77th Street — NB 7558-1921
*No. 35-42 77th Street — NB 7557-1921
*No. 35-50 77th Street — NB 7556-1921
*No. 35-56 77th Street — NB 7555-1921

Hawthorne Court, built in 1921-22 and designed by George H. Wells, is one of the characteristic garden apartment projects in Jackson Heights. The through-the-block complex consists of fourteen five-story buildings arranged as two groups of seven contiguous buildings each, one group on each blockfront and situated back-to-back across a wide common garden.

Like almost all of Wells's garden apartment complexes, Hawthorne Court is neo-Georgian in style. The brick facades are laid in Flemish bond and have white stone trim. Neo-Georgian elements include classically-inspired brick and stone entrance porticoes crowned by iron balustrades; brick banding at the first story; stone quoins at the slightly projecting central section of each facade; bandcourses, sills, and splayed lintels with keystones, all of stone; arched window openings (with arched sash) at the fifth story and at the top level of each central stairhall bay; and modillioned cornices with roofline balustrades. The projecting entrances -- a hallmark of Wells's work -- have short stoops; they alternate from building to building in the use of flat pilasters or engaged Doric columns. The designs of the iron balustrades alternate as well. The wood-and-glass entrance doors have transoms and sidelights, both of leaded glass.

Many of the original six-over-one double-hung wood sash windows survive in the buildings at 35-13 76th Street, 35-19 76th Street, 35-49 76th Street, 35-55 76th Street, 35-14 77th Street, and 35-20 77th Street; replacement windows in these buildings as well as the other buildings in this group have applied muntins in the upper sash.



Hawthorne Court

Block 1276 Lots 12, 15, 19, 22, 26, 29, 33, 50, 53, 57, 60, 64, 67 & 71

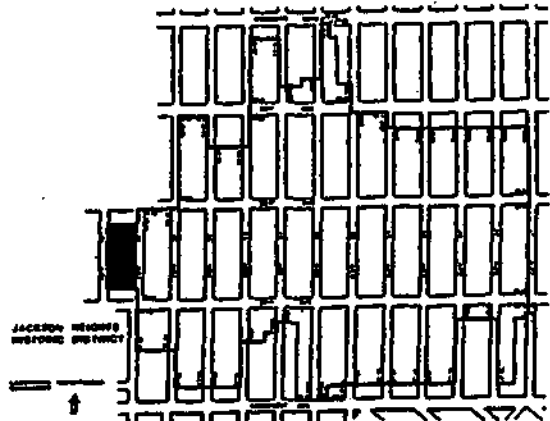
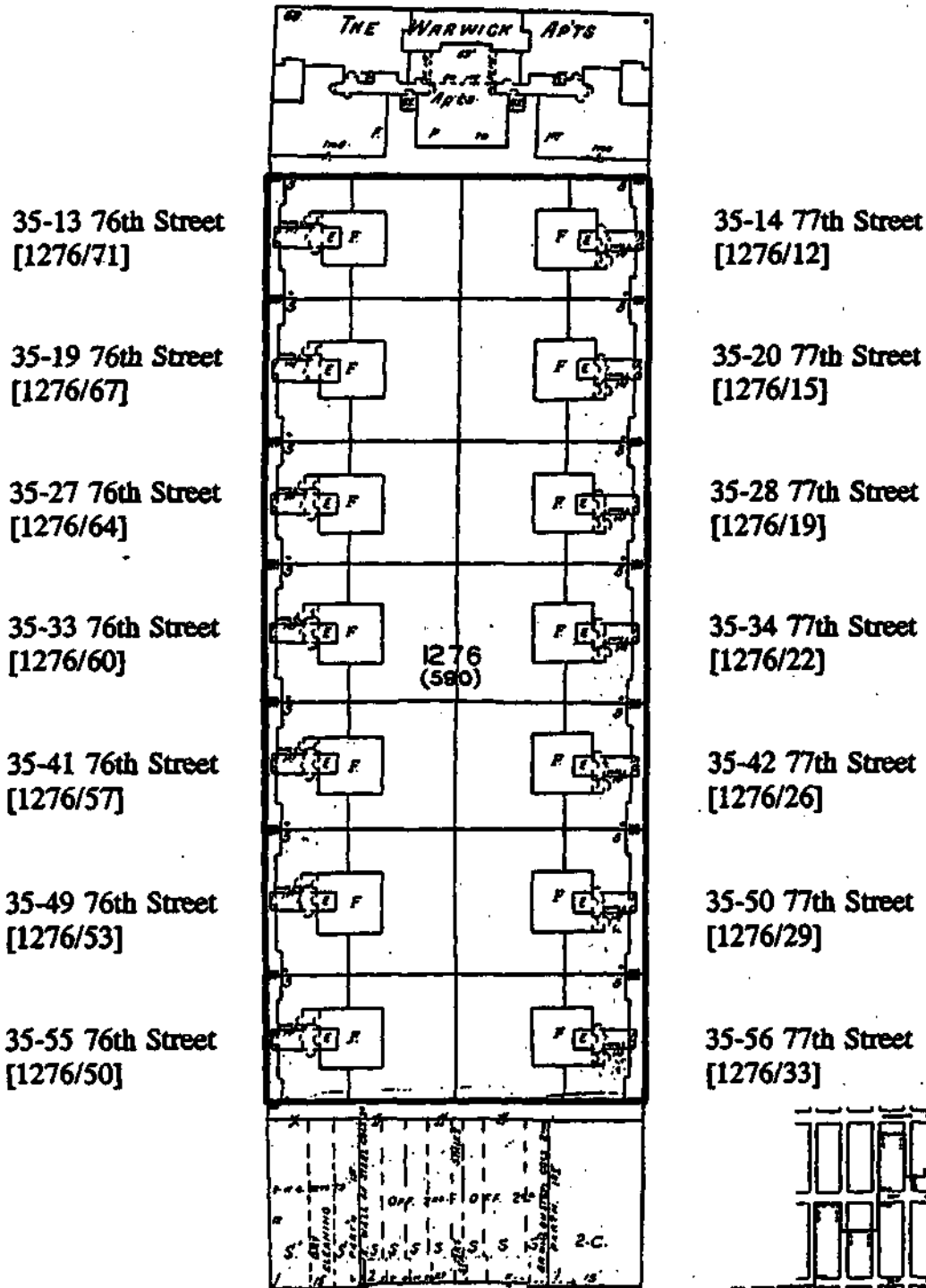

77TH STREET — East Side

77th Street between 35th Avenue and 37th Avenue (East Side)

35-01 77th Street

See: 77-02—77-12 35th Avenue

77th Street between 35th Avenue and 37th Avenue (East Side)

BERKELEY APARTMENTS

35-25 77th Street (a/k/a 35-25—35-27 77th Street)

Block/lot: 1277/58

Type: Apartment Building

Stories: 6 with basement

Style: Neo-Georgian

Date: 1936 [NB 5568-1936]

Architect: Joshua Tabatchnik

Developer: M. Goetz

Built in 1936 to designs by Joshua Tabatchnik, the six-story-and-basement Berkeley Apartments is among the later apartment buildings erected in the historic district. Typical of that phase of development, the building occupies a large mid-block site and is planned with two lightcourts which break up the long street front into three sections. The central section has a shallow recess containing the main entrance. The courts are modulated with full-height three-sided bays. The building is roughly contemporary with **Berkeley Gardens**, also designed by Tabatchnik, which is located just around the corner on 35th Avenue.

Faced in red brick with white trim, the building is a relatively ornate example of the neo-Georgian style. Elements typical of that style include the classically-inspired entrance surround (missing its broken pediment) with wood-and-glass doors and sidelights, set into a segmental arch; similar segmental arches inscribing bays at the lower stories (arched pediments removed from above the second-story windows); brickwork imitating quoins and brick band courses; paired brick pilasters supporting stone architraves with urns in relief, a motif found on the end sections of the facade; monumental temple front motifs in brick and stone, culminating in pediments at the roofline at the central section of the facade; a pitched roof with gabled dormers surmounting the central recess; and urns atop the parapets.

77th Street between 35th Avenue and 37th Avenue (East Side)

PAULDOR COURT/(now) THE JACKSON HOUSE

35-53 77th Street (a/k/a 35-53—35-55 77th Street)

Block/lot: 1277/50

Type: Apartment Building

Stories: 6 with basement

Style: Neo-Georgian

Date: 1937 [NB 189-1937]

Architect: Morris Rothstein & Son

Developer: E. Scappinato

Built in 1937 to designs by Morris Rothstein & Son, the six-story-and-basement Jackson House (formerly known as Pauldor Court) is among the later apartment buildings erected in the historic district. Typical of that phase of development, the building occupies a large mid-block site and has a deep entrance court which breaks up its street front into two sections.

Faced in red brick with white trim, the building is neo-Georgian in style. Elements which are typical of the style include the projecting gabled brick entrance porch with stone quoins, brickwork imitating quoins and rustication, brick band courses, arched window openings at the first story, tripartite windows in segmental relieving arches with swags at the second story, gables with oculi at the roofline, and parapet balustrades. Brick walls and pedestals flank the entrance to the court.

The entrance doors have been replaced.

77th Street between 35th Avenue and 37th Avenue (East Side)

35-57A—35-59 77th Street

See: 77-01—77-19 37th Avenue

77th Street between 37th Avenue and Roosevelt Avenue (East Side)

37-01 77th Street

See: 77-02 37th Avenue

77TH STREET — West Side

77th Street between 35th Avenue and 37th Avenue (West Side)

35-14—35-56 77th Street

See: 35-13—35-55 76th Street

78TH STREET — East Side

78th Street between 34th Avenue and 35th Avenue (East Side)

34-01—34-41 78th Street

See: 78-02—78-20 34th Avenue

78th Street between 35th Avenue and 37th Avenue (East Side)

35-01 78th Street

See: 78-02--78-12 35th Avenue

78th Street between 35th Avenue and 37th Avenue (East Side)

HAMPTON COURT

35-15—35-55 78th Street and 35-16—35-56 79th Street

Block/lots: 1278/70, 66, 62, 58, 54, 50 and 14, 18, 23, 27, 32

35-15 78th Street [1278/70]

35-25 78th Street [1278/66]

35-31 78th Street [1278/62]

35-37 78th Street [1278/58]

35-45 78th Street [1278/54]

35-55 78th Street [1278/50]

35-16 79th Street [1278/14]

35-26 79th Street [1278/18]

35-36 79th Street [1278/23]

35-46 79th Street [1278/27]

35-56 79th Street [1278/32]

Type: Garden Apartments (11 buildings)

Stories: 5 with basement

Style: Neo-Georgian

Date: 1919-21*

Architect: George H. Wells

Developer: Jackson Heights Apt. Corp.

*Nos. 35-15, 35-25, 35-31, 35-37, 35-45, and 35-55 78th Street — [NB 2896-1919]

*Nos. 35-16, 35-26, 35-36, 35-46, and 35-56 79th Street — [NB 2895-1919]

The Hampton Court Apartments, built in 1919-21 and designed by George H. Wells, is one of the early garden apartment projects in Jackson Heights. The complex, which occupies almost the entire block, consists of eleven five-story-and-basement walk-up buildings grouped around a common garden. Originally garden areas also occupied the open ends of the block. Today, the interior garden is accessible through passageways at the end of each blockfront of apartments. While similar, the six structures on 78th Street and the five on 79th Street are not identical. Each of the 78th Street buildings has a six-bay-wide facade with the four central bays slightly projecting, and an asymmetrically placed entrance. The 79th Street buildings have centrally-placed entrances and flanking, three-sided projecting bays.

Hampton Court, like almost all of Wells's garden apartment complexes, is neo-Georgian in style. The red brick facades are laid in Flemish bond and have white stone trim. Georgian-inspired elements include continuous stone stringcourses, modillioned cornices on 78th Street, and brick parapets with stone openwork panels on 79th Street. The entrances are within arched stone surrounds with flanking metal lamps; on 79th Street, the entrances are set within stone entablatures. The double doors are metal and glass with transoms and brass hardware. The round-headed and tripartite windows are typically neo-Georgian. All of the multi-pane double-hung wood sash, painted white, are original. The stoop railings and balconies on 78th Street appear to be recent additions.

Source: Karatzas, 54, 57, 88-89.



Hampton Court

Block 1278 Lots 14, 18, 23, 27, 32, 50, 54, 58, 62, 66 & 70

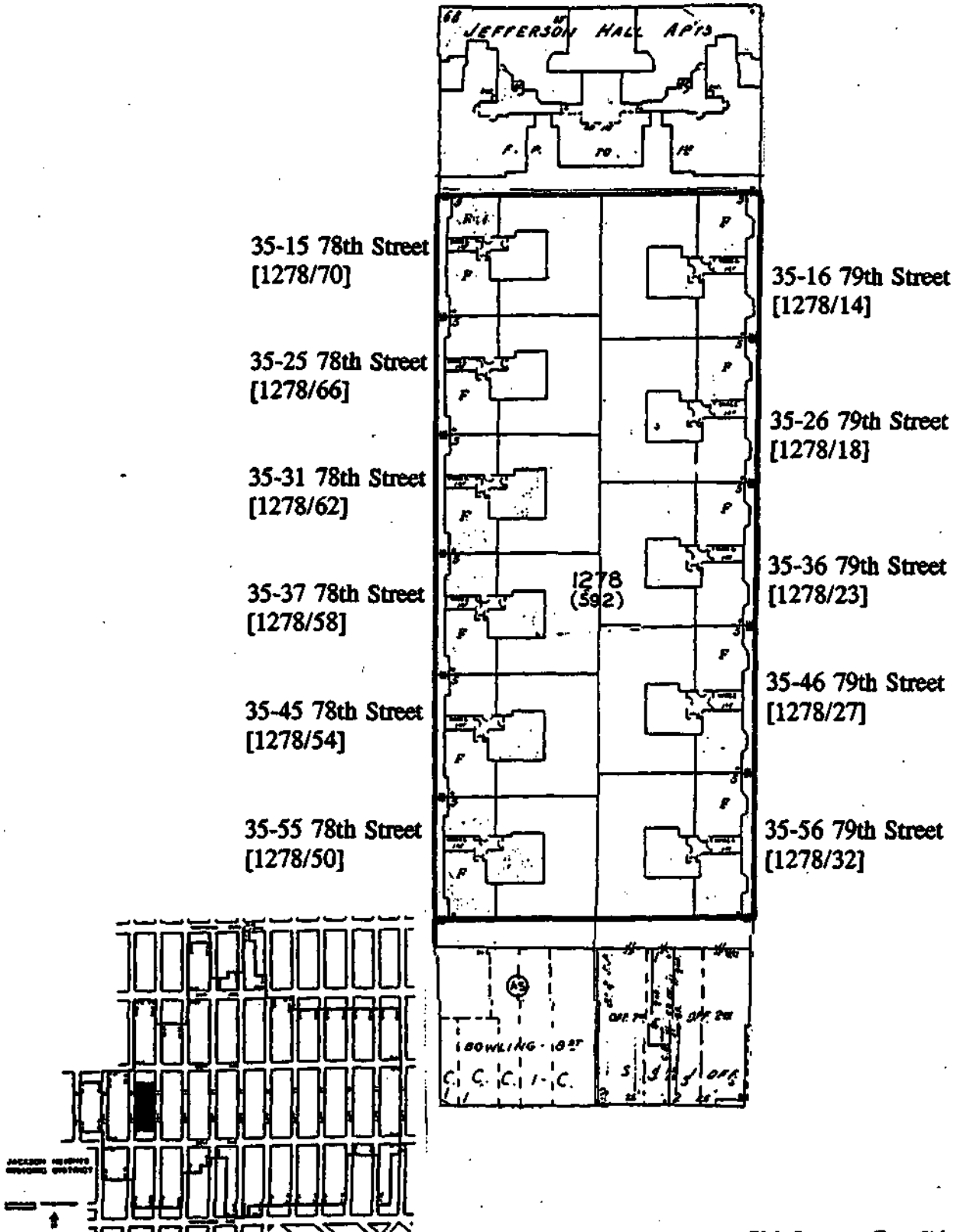

78th Street between 35th Avenue and 37th Avenue (East Side)

35-63 78th Street

See: 78-01—78-15 37th Avenue

78th Street between 37th Avenue and Roosevelt Avenue (East Side)

37-01 78th Street

See: 78-02 37th Avenue

78th Street between 37th Avenue and Roosevelt Avenue (East Side)

37-13—37-57 78th Street and 37-14—37-58 79th Street

Block/Lots: 1289/72, 71, 69, 68, 67, 66, 65, 64, 63, 62, 61, 60, 59, 58, 57, 56, 55, 54, 53, 52, 51, 50, 49 and 13, 14, 15, 16, 17, 18, 19, 20, 21, 22, 23, 24, 25, 26, 27, 28, 29, 31, 32, 33, 34, 35, 37

37-13 78th Street [1289/72]

37-15 78th Street [1289/71]

37-17 78th Street [1289/69]

37-19 78th Street [1289/68]

37-21 78th Street [1289/67]

37-23 78th Street [1289/66]

37-25 78th Street [1289/65]

37-27 78th Street [1289/64]

37-29 78th Street [1289/63]

37-31 78th Street [1289/62]

37-33 78th Street [1289/61]

37-35 78th Street [1289/60]

37-37 78th Street [1289/59]

37-39 78th Street [1289/58]

37-41 78th Street [1289/57]

37-43 78th Street [1289/56]

37-45 78th Street [1289/55]

37-47 78th Street [1289/54]

37-49 78th Street [1289/53]

37-51 78th Street [1289/52]

37-53 78th Street [1289/51]

37-55 78th Street [1289/50]

37-57 78th Street [1289/49]

37-14 79th Street [1289/13]

37-16 79th Street [1289/14]

37-18 79th Street [1289/15]

37-20 79th Street [1289/16]

37-22 79th Street [1289/17]

37-24 79th Street [1289/18]

37-26 79th Street [1289/19]

37-28 79th Street [1289/20]

37-30 79th Street [1289/21]

37-32 79th Street [1289/22]

37-34 79th Street [1289/23]

37-36 79th Street [1289/24]

37-38 79th Street [1289/25]

37-40 79th Street [1289/26]

37-42 79th Street [1289/27]

37-44 79th Street [1289/28]

37-46 79th Street [1289/29]

37-48 79th Street [1289/31]

37-50 79th Street [1289/32]

37-52 79th Street [1289/33]

37-54 79th Street [1289/34]

37-56 79th Street [1289/35]

37-58 79th Street [1289/37]

Type: Attached & Semi-Detached Houses

(46 buildings)

Stories: 2 and one-half

Style: Anglo-American Garden Home

Date: 1926-27*

Architect: Benjamin Dreisler, Jr.

Developer: J.H. Kleinman Construction Corp.

*Nos. 37-13, 37-15, 37-17, 37-19, 37-21, and 37-23 78th Street — NB 10916-1926

*Nos. 37-25, 37-27, 37-29, 37-31, 37-33, and 37-35 78th Street — NB 10918-1926

*Nos. 37-37, 37-39, 37-41, 37-43, 37-45, and 37-47 78th Street — NB 11924-1926

*Nos. 37-49, 37-51, 37-53, 37-55, and 37-57 78th Street — NB 11923-1926

- *Nos. 37-14, 37-16, 37-18, 37-20, 37-22, and 37-24 79th Street — NB 9211-1926:
- *Nos. 37-26, 37-28, 37-30, 37-32, 37-34, and 37-36 79th Street — NB 10917-1926
- *Nos. 37-50, 37-52, 37-54, 37-56, and 37-58 79th Street — NB 11921-1926
- *Nos. 37-38, 37-40, 37-42, 37-44, 37-46, and 37-48 79th Street — NB 11922-1926

This group of forty-six houses, arranged on a block plan with back-to-back clusters facing 78th and 79th streets, between 37th Avenue and Roosevelt Avenue, is characteristic of many similar groups of attached and semi-detached houses built in Jackson Heights during the second half of the 1920s. Built in 1926-27, the houses were designed by Benjamin Dreisler, Jr. On each blockfront are twenty-three houses organized into four clusters, three with six houses each and one with five.

Each six-house cluster is designed in an "a-b-c-b-a" pattern, and each of the two five-house clusters, which back onto each other at the southern end of the group, are designed in an "a-b-c-b-a" pattern. These symmetrical configurations produce the effect that each cluster is a larger single entity. The placement of the entrances in a mirror-image formation, the alternating roof profiles, and the window arrangement all reinforce the symmetry of each group, and the overall consistency of the patterning gives each blockfront a cohesive design.

The design of the houses is derived largely from the neo-Georgian style. Elements typical of that style are the red brick facing laid in Flemish bond; pitched-roof front porches ("a" and "c" houses); umbrella hoods over the porches of the intervening ("b") houses; fanlight transoms; terra-cotta rosettes and scallop shells; multi-pane double-hung windows; a modified Palladian window form ("c" houses); and pitched tile roofs with gables, shed dormers, and chimneys. The side facades of the end houses are visible from the street. The houses have front gardens. Driveways leading to the interior of the block are entered at the ends of the blockfronts. A garage is located in the rear of the basement of each house. Alterations include replacement doors, additions of low walls and fences at the sidewalk.



37-13—37-57 78th Street and 37-14—37-58 79th Street

Block 1289 Lots 13-35, 37, 49-69, 71 & 72

37-13 78th Street [1289/72]
 37-15 78th Street [1289/71]
 37-17 78th Street [1289/69]
 37-19 78th Street [1289/68]
 37-21 78th Street [1289/67]
 37-23 78th Street [1289/66]

37-25 78th Street [1289/65]
 37-27 78th Street [1289/64]
 37-29 78th Street [1289/63]
 37-31 78th Street [1289/62]
 37-33 78th Street [1289/61]
 37-35 78th Street [1289/60]

37-37 78th Street [1289/59]
 37-39 78th Street [1289/58]
 37-41 78th Street [1289/57]
 37-43 78th Street [1289/56]
 37-45 78th Street [1289/55]
 37-47 78th Street [1289/54]

37-49 78th Street [1289/53]
 37-51 78th Street [1289/52]
 37-53 78th Street [1289/51]
 37-55 78th Street [1289/50]
 37-57 78th Street [1289/49]

37-14 79th Street [1289/13]
 37-16 79th Street [1289/14]
 37-18 79th Street [1289/15]
 37-20 79th Street [1289/16]
 37-22 79th Street [1289/17]
 37-24 79th Street [1289/18]

37-26 79th Street [1289/19]
 37-28 79th Street [1289/20]
 37-30 79th Street [1289/21]
 37-32 79th Street [1289/22]
 37-34 79th Street [1289/23]
 37-36 79th Street [1289/24]

37-38 79th Street [1289/25]
 37-40 79th Street [1289/26]
 37-42 79th Street [1289/27]
 37-44 79th Street [1289/28]
 37-46 79th Street [1289/29]
 37-48 79th Street [1289/31]

37-50 79th Street [1289/32]
 37-52 79th Street [1289/33]
 37-54 79th Street [1289/34]
 37-56 79th Street [1289/35]
 37-58 79th Street [1289/37]

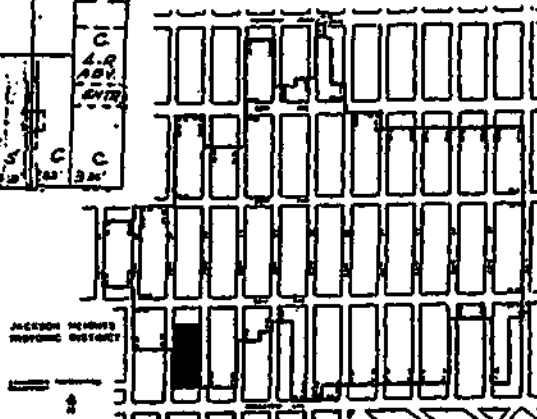
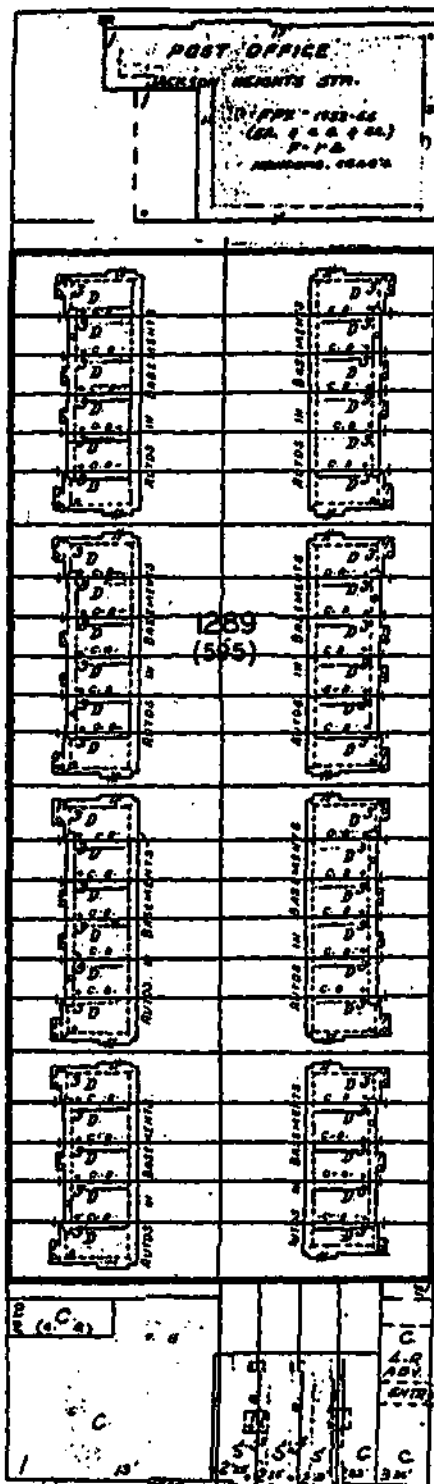

78TH STREET — West Side

78th Street between 35th Avenue and 37th Avenue (West Side)

35-02 78th Street

See: 77-02—77-12 35th Avenue

78th Street between 35th Avenue and 37th Avenue (West Side)

35-24—35-28 78th Street

Block/lot: 1277/12

Type: Apartment Building
Stories: 6 with basement
Style: Neo-Georgian

Date: 1938 [NB 315-1938]
Architect: Philip Birnbaum
Developer: Berkeley Gardens

Built in 1938 to designs by Philip Birnbaum, this six-story-and-basement building is among the later apartment buildings erected in the historic district. Typical of that phase of development, the brick-faced building occupies a large mid-block site and is planned with two lightcourts which break up its long street front into three sections. The central entrance pavilion and the flanking courts are modulated with full-height three-sided bays.

Philip Birnbaum is known for his modern buildings of the post-war era, several of which are located in the district. The architect's 1938 design for this building is derived from the popular neo-Georgian style, but also shows modernistic influence. Georgian-inspired elements include large triangular and segmentally-arched pediments at the roofline, bricks laid to suggest quoins, and decorative swags on the entrance canopy. More modernistic are the treatment of the angled bays, the stylized brick banding and the brick channeling around the paneled entranceway, and the metal balconette railings with a geometric design.

78th Street between 35th Avenue and 37th Avenue (West Side)

THE GENARD/(now) THE JACKSON

35-50 (a/k/a 35-50—35-56) 78th Street

Block/lots: 1277/1000-1057

Type: Apartment Building
Stories: 6 with basement
Style: Neo-Georgian

Date: 1937 [NB 437-1937]
Architect: Julius Fishkin
Developer: Genard Building Corp.

Built in 1937 to designs by Julius Fishkin, the six-story-and-basement Jackson Apartments (formerly known as the Genard) is among the later apartment buildings erected in the historic district. Typical of that phase of development, the building occupies a large mid-block site and has a deep entrance court which breaks up its street front into two sections.

Faced in red brick with white trim, the building is neo-Georgian in style. Elements which are typical of the style include brickwork imitating quoins and brick band courses; relieving arches with brick headers; stone keystones; tripartite windows in stone Palladian-inspired surrounds at the first story; iron balconettes and iron fences in sections of the parapet; monumental brick pilasters supporting an architrave on each of the building's two sections; and pediment motifs at the roofline. Low brick walls enclose the

planting beds in the court. The southern elevation of the building, visible above the adjacent one-story building, continues a few of the facade's design motifs.

The entrance has been replaced. Most of the building's original six-over-six double-hung wood sash windows survive.

78th Street between 35th Avenue and 37th Avenue (West Side)

35-58A—35-60 78th Street

See: 77-01—77-19 37th Avenue

78th Street between 37th Avenue and Roosevelt Avenue (West Side)

37-02 78th Street

See: 77-02 37th Avenue

79TH STREET — East Side

79th Street between 34th Avenue and 35th Avenue (East Side)

ELM COURT

34-27—34-49 79th Street and 34-28—34-50 80th Street
Block/lots: 1266/58, 54, 51, 47, 19, 22, 26, 29

34-27 79th Street [1266/58]	34-28 80th Street [1266/19]
34-35 79th Street [1266/54]	34-36 80th Street [1266/22]
34-41 79th Street [1266/51]	34-42 80th Street [1266/26]
34-43—34-49 79th Street [1266/47]	34-50 80th Street [1266/29]

Type: Garden Apartments (8 buildings)
Stories: 4 with basement
Style: Neo-Georgian

Date: 1921-22*
Architect: George H. Wells
Developer: Jackson Heights Apartment Corp.

- *Nos. 34-27 and 34-35 79th Street — [NB 6080-1921]
- *Nos. 34-41 and 34-43—34-49 79th Street — [NB 6079-1921]
- *Nos. 34-28 and 34-36 80th Street — [NB 6082-1921]
- *Nos. 34-42 and 34-50 80th Street — [NB 6081-1921]

Elm Court, built in 1921-22 and designed by George H. Wells, is one of the characteristic garden apartment projects in Jackson Heights. The through-the-block complex consists of eight four-story-and-basement buildings, arranged with four contiguous buildings on each blockfront, situated back-to-back across a wide common garden.

Elm Court, like almost all of Wells's garden apartment complexes, is neo-Georgian in style. The brick facades are laid in Flemish bond and have stone trim. Neo-Georgian elements include classically-inspired brick and stone entrance porticoes crowned by balustrades; brick banding at the basement and brick quoins at the slightly projecting central section of each facade; bandcourses, sills, and splayed lintels with keystones, all of stone; arched window openings at the top level of each central stairhall bay; and modillioned cornices with roofline balustrades. The projecting entrances — a hallmark of Wells's work — have short stoops. The wood-and-glass entrance doors are set into openings with elliptical fanlights and sidelights, both of leaded glass. All of the original entrances survive, as do the original six-over-one double-hung wood sash windows.

79th Street between 35th Avenue and 37th Avenue (East Side)

35-01 79th Street

See: 79-02—79-10 35th Avenue

79th Street between 35th Avenue and 37th Avenue (East Side)

MONROE HOUSE

35-21 79th Street

Block/lot: 1279/58

Type: Apartment Building

Stories: 6 with basement

Style: Neo-Georgian (post-World War II)

Date: 1947-48 [NB 941-1945]

Architect: William Hohausser

Developer: Apartment Building Corp.

Designed by William Hohausser and built in 1947-48, the six-story-and-basement Monroe House is one of several apartment buildings constructed in the post-World War II era of development in Jackson Heights. Continuing the trend of the pre-War years, it is a large building on a mid-block site and planned with two lightcourts which break up its long street front into three sections.

The brick facades of the Monroe House feature a modest application of Georgian-inspired ornamental details, limited to stone stringcourses at the base and top, an intermediate decorative brick band course, and small classically-inspired stone plaques at the parapet. The entrance, located in the wide central section, is cut into a broad cast-stone facing.

79th Street between 35th Avenue and 37th Avenue (East Side)

HAMPSHIRE HOUSE

35-45 79th Street

Block/lot: 1279/46

Type: Apartment Building

Stories: 6 with basement

Style: Neo-Georgian

Date: 1938-40 [NB 2349-1938]

Architect: B. Cohn

Developer: Jardino Construction Corp.

Built in 1938-40 to designs by B. Cohn, the six-story-and-basement Hampshire House is among the later apartment buildings erected in the historic district. Typical of that phase of development, it is a large building on a mid-block site and planned with two recessed lightcourts which break up the street front into three sections; the entrance is located in the central section.

Neo-Georgian in style, the building is ornamented with monumental temple-front motifs applied to the four upper stories of each of the three sections, culminating in pediments at the roofline; the central motif has stone pilasters, while those at each end have brick pilasters with stone trim. Paired white colonnettes supporting a lintel surround the arched entrance. Other neo-Georgian elements include brick patterning suggestive of quoins; stone-filled arches simulating fanlights; stone oculi and keystones; and a stone water table. The recessed lightcourts contain decorated iron fire escapes. Fixed awnings have been added at the entryway.

79th Street between 35th Avenue and 37th Avenue (East Side)

35-63 79th Street

See: 79-01—79-27 37th Avenue

79th Street between 37th Avenue and Roosevelt Avenue (East Side)

37-01—37-05 79th Street

See: 79-02 37th Avenue

79th Street between 37th Avenue and Roosevelt Avenue (East Side)

LABURNUM COURT

37-15—37-31 79th Street and 37-16—37-32 80th Street

Block/lots: 1290/67, 68, 13

37-15 and 37-21 79th Street [1290/67]

37-27 and 37-31 79th Street [1290/61]

37-16, 37-22, 37-28 and 37-32 80th Street

[1290/13]

Type: Garden Apartments (8 buildings)

Stories: 5 with basement

Style: Neo-Georgian

Date: 1921-22 [NB 4878-1921]

Architect: George H. Wells

Developer: Jackson Heights Corp.

Laburnum Court, built in 1921-22 and designed by George H. Wells, is one of the characteristic garden apartment projects in Jackson Heights. The complex consists of eight five-story-and-basement buildings; the buildings are arranged in two groups, each with four contiguous buildings. The groups are situated back-to-back and share a wide common garden. Each of the two streetfronts of Laburnum Court is massed with two recessed entrance courts which break up the streetfront into three sections. This creates the effect of one large structure with pavilions at the ends and center.

Laburnum Court, like almost all of Wells's garden apartment complexes, is neo-Georgian in style. Above a stone watertable, the red brick facades are laid in Flemish bond and have white stone trim. Neo-Georgian elements include classically-inspired stone and brick entrance porticoes crowned by iron balconies; brick banding at the first story; stone bandcourses, sills, and keystones; arched window openings at the fifth story; and bracketed cornices with roofline balustrades. The courtyards include concrete steps and walks lined with iron railings. The entrance doors have been replaced, and chain-link fences have been added in the courts. The interior garden, occupying the greater part of the site, is partially visible through the passageways at each end of the streetfronts.



Laburnum Court

Block 1290 Lots 13, 67 & 68

37-15 79th Street

[1290/67]

37-21 79th Street

37-27 79th Street

[1290/61]

37-31 79th Street

37-16 80th Street

[1290/13]

37-22 80th Street

37-28 80th Street

[1290/13]

37-32 80th Street

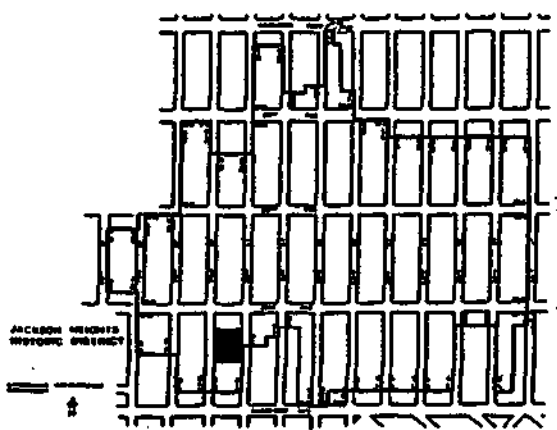
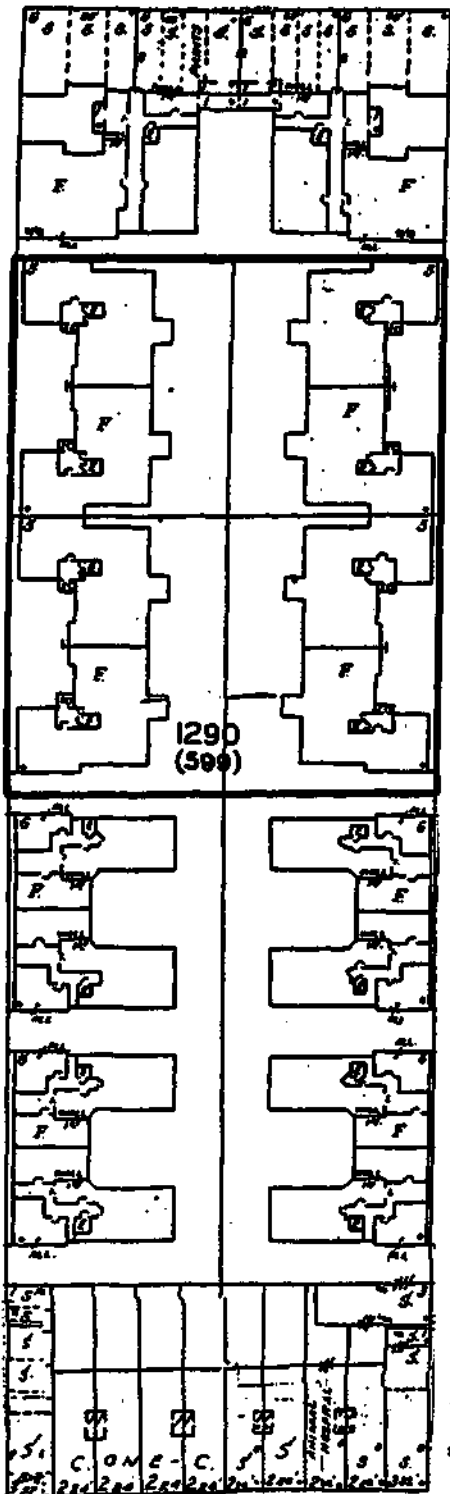

79th Street between 37th Avenue and Roosevelt Avenue (East Side)

HAMILTON COURT

37-41—37-55 79th Street and 37-42—37-56 80th Street

Block/lots: 1290/54, 49, 25, 29

37-41 and 37-45 79th Street [1290/54]

37-51 and 37-55 79th Street [1290/49]

37-42 and 37-46 80th Street [1290/25]

37-52 and 37-56 80th Street [1290/29]

Type: Garden Apartments (8 buildings)

Stories: 6

Style: Neo-Tudor

Date: 1925-26*

Architect: H. Hamilton

Developer: Equi Corp.

*Nos. 37-41, 37-45 79th Street — [NB 8337-1925]

*Nos. 37-51, 37-55 79th Street — [NB 8336-1925]

*Nos. 37-42, 37-46 80th Street — [NB 8334-1925]

*Nos. 37-52, 37-56 80th Street — [NB 8335-1925]

Hamilton Court, designed by H. Hamilton in the neo-Tudor style, was built in 1925-26 and is one of the later garden apartment projects developed in Jackson Heights. The complex consists of eight six-story buildings grouped into pairs, with two pairs each on 78th and 79th streets; these pairs are situated back-to-back and share a common interior garden. The garden is accessible through brick entrance gates at the streetfront, spanning the passageways between the buildings.

The neo-Tudor style of the complex is articulated by stone Tudor-arched and segmentally-arched window heads and entrances; irregular stone rustication; random quoins; tapestry brick facing; brick laid to suggest half-timbering at the upper stories of the central bays of each pair; crenelated parapets; and tower-like projections at the roofline above the entrance bays. The end bays of each pair project slightly and are topped by mansard roofs. The buildings retain the original eight-over-eight and six-over-six double-hung wood sash windows. Nos. 37-51--37-55 79th Street and 37-52--37-56 80th Street have new roofs, repointing, and permastone resurfacing around the entries.



Hamilton Court

Block 1290 Lots 25, 29, 49 & 54

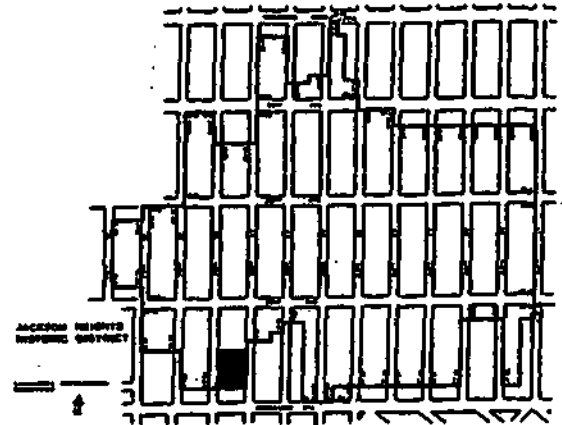
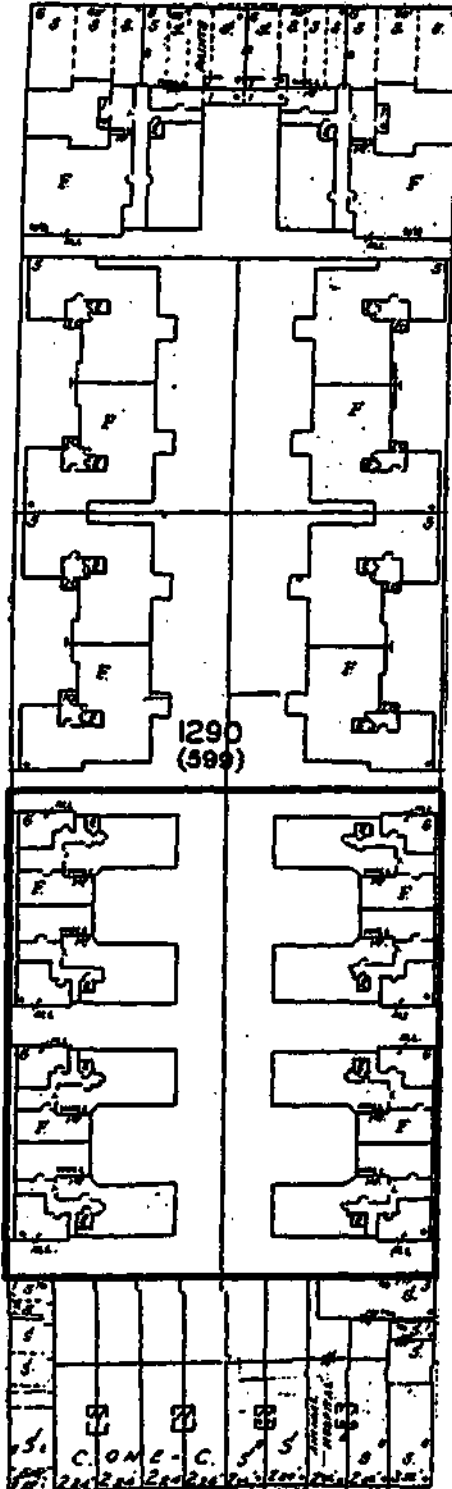

37-41 79th Street

[1290/54]

37-45 79th Street

37-51 79th Street

[1290/49]

37-55 79th Street

37-42 80th Street

[1290/25]

37-46 80th Street

37-52 80th Street

[1290/29]

37-56 80th Street

79TH STREET — West Side

79th Street between 34th Avenue and 35th Avenue (West Side)

34-02—34-42 79th Street

See: 78-02—78-20 34th Avenue

79th Street between 35th Avenue and 37th Avenue (West Side)

35-02 79th Street

See: 78-02--78-12 35th Avenue

79th Street between 35th Avenue and 37th Avenue (West Side)

35-16—35-56 79th Street

See: 35-15—35-55 78th Street

79th Street between 35th Avenue and 37th Avenue (West Side)

35-64 79th Street

See: 78-17—78-27 37th Avenue

79th Street between 37th Avenue and Roosevelt Avenue (West Side)

37-02 79th Street

See: 78-02 37th Avenue

79th Street between 37th Avenue and Roosevelt Avenue (West Side)

37-16—37-58 79th Street

See: 37-13—37-57 78th Street

80TH STREET — East Side

80th Street between Northern Boulevard and 34th Avenue (East Side)

THE TOWERS

33-15—33-51 80th Street and 33-16—33-52 81st Street

Block/lot: 1253/1

33-15 80th Street

33-27 80th Street

33-39 80th Street

33-51 80th Street

33-16 81st Street

33-28 81st Street

33-40 81st Street

33-52 81st Street

Type: Garden Apartments (8 buildings)

Stories: 6

Style: Neo-Romanesque

Date: 1923-25*

Architect: Andrew J. Thomas

Developer: Queensboro Corp.

*No. 33-15 80th Street — NB 3133-1923

*No. 33-27 80th Street — NB 3131-1923

*Nos. 33-39 and 33-51 80th Street —
NB 3129-1923

*No. 33-16 81st Street — NB 3132-1923

*No. 33-28 81st Street — NB 3130-1923

*No. 33-40 81st Street — NB 3128-1923

*No. 33-52 81st Street — NB 3126-1923

The Towers, built in 1923-25 to designs by Andrew J. Thomas, is one of the Queensboro Corporation's early garden apartment complexes in Jackson Heights. Occupying most of the block, the complex consists of eight freestanding U-shaped buildings, four along each blockfront, which are situated back-to-back across a common landscaped garden at the interior of the block. The garden opens onto 34th Avenue and is clearly visible from the street. The three street fronts around the complex are also lined with gardens and iron fences. The passageways between the buildings are spanned by brick walls and entrance gates.

Each blockfront of four six-story brick buildings with masonry trim is arranged in a "A-B-B-A" pattern. The inner buildings ("B") are symmetrically massed and have prominent entrances at the center, while the outer buildings ("A") are asymmetrically massed and have corner towers marking the ends of the complex.

The style of the Towers is derived from Italian Romanesque and Renaissance architecture. Particularly suggestive of this inspiration are the palazzo-like massing; the red tile roofs with overhanging eaves; the arcaded sixth-story loggias and tower belvederes ("A"); the round attic-story windows ("A"); and the arched stone entrance surrounds which are either keyed ("A") or rusticated ("B") and topped by cartouches. Other notable features include the iron and glass double doors with fanlights, decorative bandcourses, stone trim at the towers and loggias, balustraded balconettes, and large stone griffons flanking the iron gates leading to the interior garden. The rear facades of the Towers, partially visible from the street, are somewhat plainer than the street facades, but continue some of the design elements.

Many original six-over-six wood sash windows survive behind storm sash.



The Towers

Block 1253 Lot 1

33-15 80th Street

33-27 80th Street

33-39 80th Street

33-51 80th Street

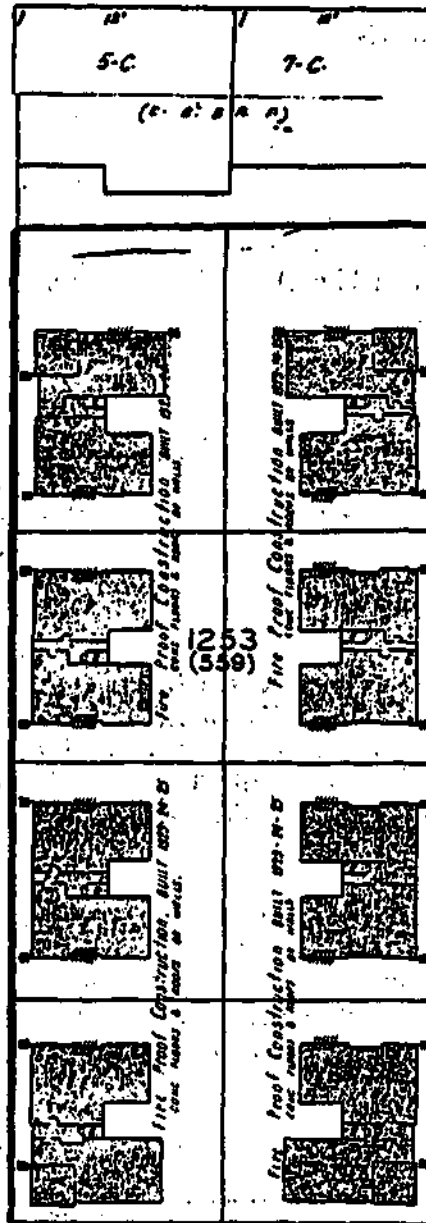

33-16 81st Street

33-28 81st Street

33-40 81st Street

33-52 81st Street

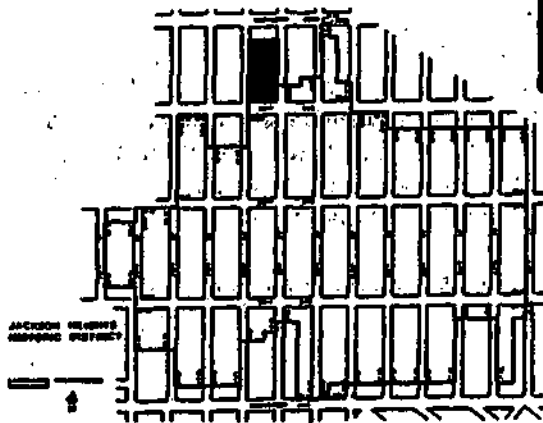

80th Street between 34th Avenue and 35th Avenue (East Side)

THE CHATEAU

34-01—34-47 80th Street and 34-02—34-48 81st Street

Block/lot: 1267/1, 64, 60, 55, 51, 46, 6, 12, 16, 20, 24, 28

34-01—34-05 80th Street [1267/1]

34-13 80th Street [1267/64]

34-21 80th Street [1267/60]

34-29 80th Street [1267/55]

34-37 80th Street [1267/51]

34-47 80th Street [1267/46]

34-02—34-06 81st Street [1267/6]

34-14 81st Street [1267/12]

34-22 81st Street [1267/16]

34-30 81st Street [1267/20]

34-38 81st Street [1267/24]

34-48 81st Street [1267/28]

Type: Garden Apartments (12 buildings)

Stories: 5 and 6

Style: Neo-French Renaissance

Date: 1922*

Architect: Andrew J. Thomas

Developer: Queensboro Corp.

*No. 34-01—34-05 80th Street — NB 567-1922

*No. 34-13 80th Street — NB 555-1922

*No. 34-21 80th Street — NB 552-1922

*No. 34-29 80th Street — NB 550-1922

*No. 34-37 80th Street — NB 556-1922

*No. 34-47 80th Street — NB 569-1922

*No. 34-02—34-06 81st Street — NB 566-1922

*No. 34-14 81st Street — NB 554-1922

*No. 34-22 81st Street — NB 551-1922

*No. 34-30 81st Street — NB 549-1922

*No. 34-38 81st Street — NB 553-1922

*No. 34-48 81st Street — NB 568-1922

The Chateau, built in 1922 to designs by Andrew J. Thomas, is one of the Queensboro Corporation's early garden apartment complexes in Jackson Heights. Occupying most of the block, the complex consists of twelve freestanding U-shaped buildings, six along each blockfront, which are situated back-to-back across a common landscaped garden at the interior of the block. The large garden opens onto 34th Avenue and is clearly visible from the street. The three street fronts around the complex are also lined with gardens. The passageways between the buildings are spanned by brick walls and iron entrance gates.

Each blockfront of six brick buildings with masonry trim is arranged in a "A-B-C-C-B-A" pattern. The outer buildings ("A") are asymmetrically massed, each with a five-story section at the center flanked by a six-story projecting section and a corner tower; the towers mark the ends of the complex. The ("B") buildings are symmetrical five-story buildings with flush facades, while the center buildings ("C") are mirror images with slightly projecting sections which mark the center of the block.

The style of the Chateau, derived from French Renaissance architecture, has been described as "reminiscent of the architecture of Henri IV of France." Particularly suggestive of this inspiration are the imposing slate mansard roofs with dormers and finials; the Flemish bond brick facing and the decorative banding; the diaperwork patterning on the towers of the "A" buildings; the brick chimneys with decorative tops; and the stone entry portals, flanked by decorative colonnettes and capped by hoods. The segmentally-arched door openings contain glass doors with decorative iron grilles. All of the original doors survive. Almost all of the original four-over-four double-hung wood sash windows survive, as do most of the multi-pane wood casement windows in the towers of the "A" buildings.

The rear facades of the Chateau continue the style of the street facades. They are partially visible from the sidewalks outside the complex, especially on 34th Avenue.

Source: *New York Times*, May 3, 1922.



The Chateau

Block 1267 Lots 1, 6, 12, 16, 20, 24, 28, 46, 51, 55, 60 & 64

34-01 80th Street
34-05 80th Street
[1267/1]

34-13 80th Street
[1267/64]

34-21 80th Street
[1267/60]

34-29 80th Street
[1267/55]

34-37 80th Street
[1267/51]

34-47 80th Street
[1267/46]

34-02 81st Street
34-06 81st Street
[1267/6]

34-14 81st Street
[1267/12]

34-22 81st Street
[1267/16]

34-30 81st Street
[1267/20]

34-38 81st Street
[1267/24]

34-48 81st Street
[1267/28]

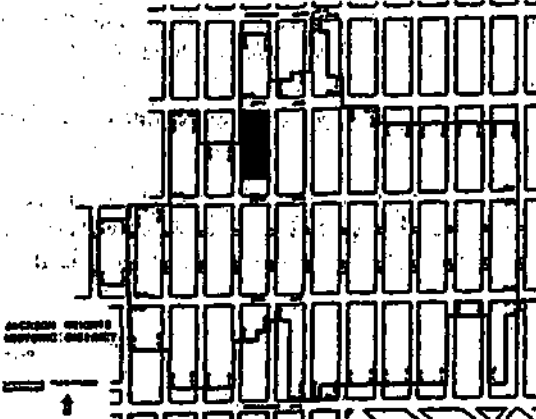
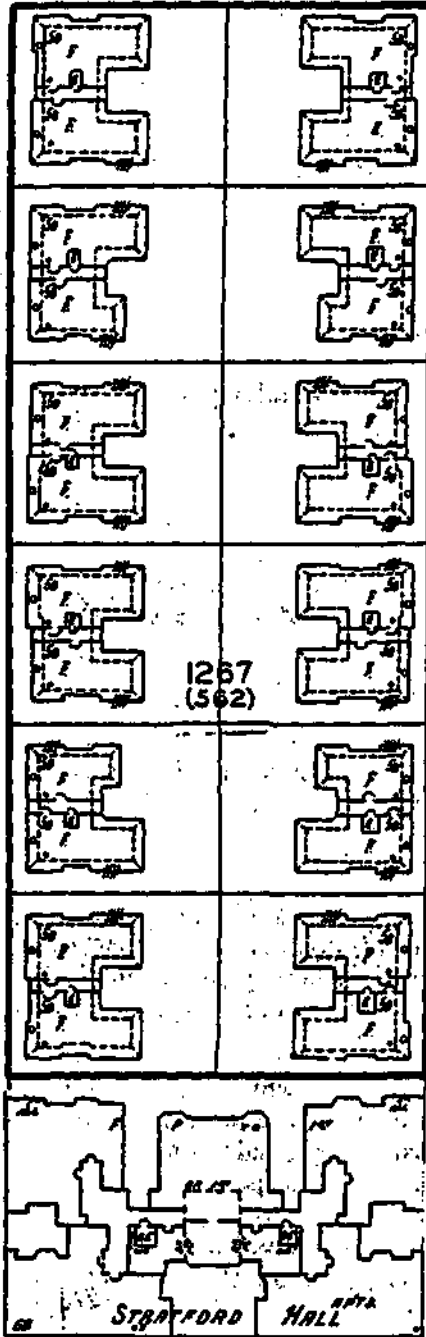

80th Street between 35th Avenue and 37th Avenue (East Side)

35-01 80th Street *See: 80-02—80-08 35th Avenue*

80th Street between 35th Avenue and 37th Avenue (East and West Sides)

THE GREYSTONE APARTMENTS

35-15—35-55 80th Street and 35-16—35-54 80th Street

Blocks/lots: 1280/66, 63, 60, 57, 54, 51, 48 and 1279/12, 15, 18, 21, 24, 27, 30

35-15 80th Street [1280/66]	35-16 80th Street [1279/12]
35-21 80th Street [1280/63]	35-22 80th Street [1279/15]
35-27 80th Street [1280/60]	35-28 80th Street [1279/18]
35-33 80th Street [1280/57]	35-36 80th Street [1279/21]
35-41 80th Street [1280/54]	35-42 80th Street [1279/24]
35-47 80th Street [1280/51]	35-48 80th Street [1279/27]
35-55 80th Street [1280/48]	35-54 80th Street [1279/30]

Type: Garden Apartments (14 buildings)

Stories: 5 with basement

Style: Neo-Tudor

Date: 1916-18*

Architect: George H. Wells

Developer: Jackson Heights Apt. Corp.

- *Nos. 35-15, 35-21, 35-27, and 35-33 80th Street — [NB 4166-1916]
- *Nos. 35-16, 35-22, 35-28, and 35-36 80th Street — [NB 4167-1916]
- *Nos. 35-41, 35-47, and 35-55 80th Street — [NB 3592-1916]
- *Nos. 35-42, 35-48, and 35-54 80th Street — [NB 3593-1916]

Designed by George H. Wells and built in 1916-18, the Greystone Apartments was the first of the garden apartment complexes to be built in Jackson Heights. The complex -- at first named the Garden Apartments -- creates a unified streetscape of two facing blockfronts, each with landscaped front gardens. Each blockfront consists of contiguous "T"-shaped buildings, each covering about thirty-eight percent of its roughly sixty-three by 100-foot lot. The rear courtyards open onto the unbuilt rear portions of the lots, which are treated as undivided property and landscaped as continuous gardens behind each blockfront.

The Greystone Apartments are faced with gray brick and have stone basements and keyed stone window trim. The ornamental treatment is largely inspired by Tudor architecture. Details typical of that style include the continuous crenelated parapets, the projecting tower-like entrance bays, and especially the projecting Tudor-arched entry porches with ogival leaded-glass transoms, panels, and finials.

While similar, the fourteen five-story-and-basement brick buildings are not identical; rather, there are alternating "A" and "B" types which are differentiated by certain ornamental details. In the "A" type, the portal's entablature consists of three diamond-shaped panels, the flanking pilasters have a V-shaped profile and are topped by pyramidal finials, the slightly projecting entrance bay is crowned with a triangular pediment, and brick diaperwork accents the top story. In the "B" type, the portal's entablature has five quatrefoil panels, the flanking pilasters have a round profile and are topped with cylindrical finials, and the projecting entrance bay is crowned with a squared pediment and a stone parapet. Both building designs include a narrow slit window in the center of the pediment, adding to the castle-like effect.

The interior gardens are not visible from the sidewalk; rather, they are entered from passages at the ends of the blockfronts. The avenue ends of the blocks were originally landscaped. The rear elevations of the buildings are faced with beige-colored brick. Original four-over-one wood sash windows survive in most of the buildings (some are covered with storm sash).

Source: Karatzas, 30; 1918 photo.



The Greystone Apartments

Block 1279 Lots 12, 15, 18, 21, 24, 27 & 30

Block 1280 Lots 48, 51, 54, 57, 60, 63 & 66

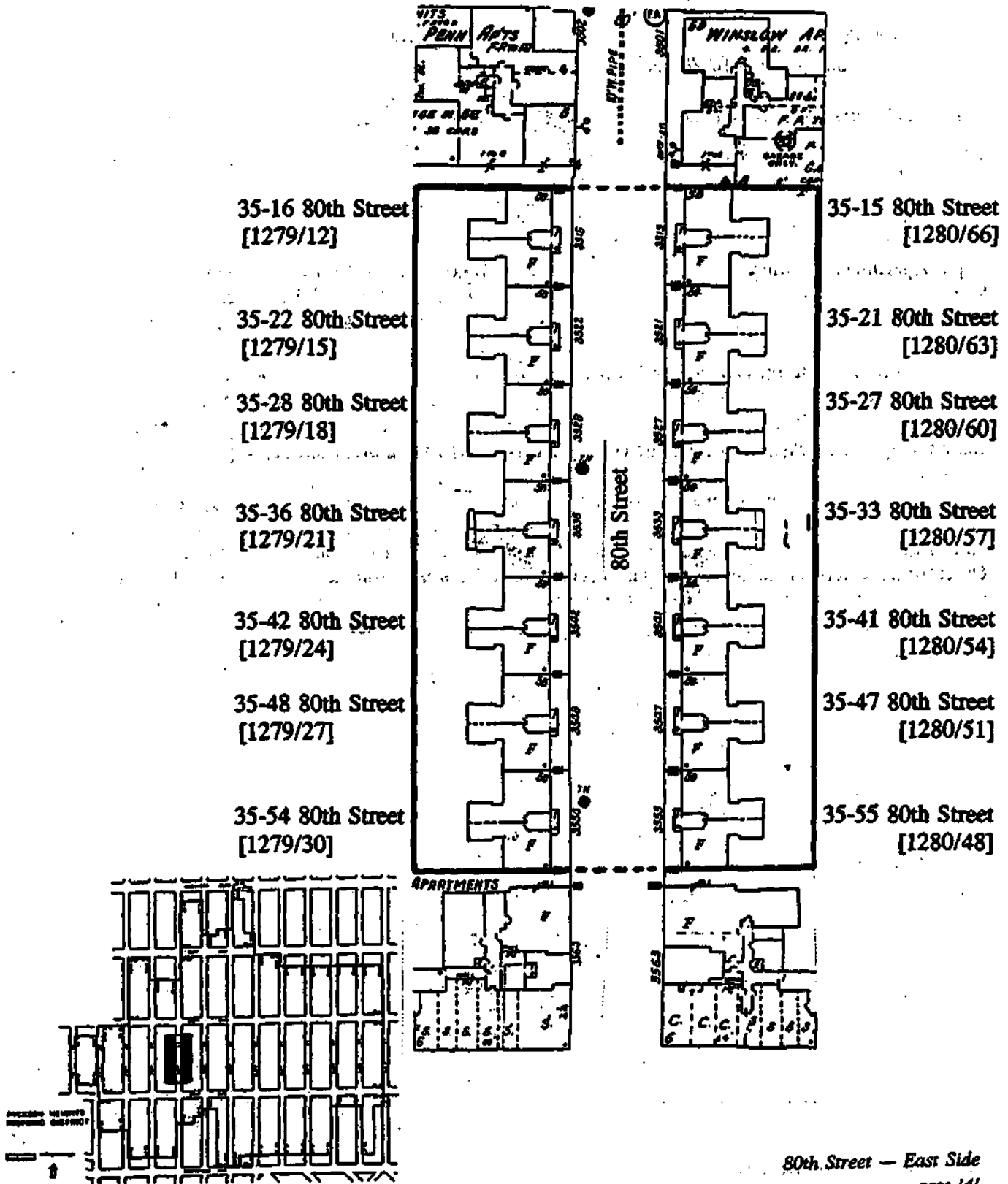

80th Street between 35th Avenue and 37th Avenue (East Side)

35-63 80th Street

See: 80-01—80-29 37th Avenue

80th Street between 37th Avenue and Roosevelt Avenue (East Side)

37-01—37-05 80th Street

See: 80-02—80-28 37th Avenue

80th Street between 37th Avenue and Roosevelt Avenue (East Side)

THE ELDORADO APARTMENTS

37-15—37-21 80th Street

Block/lot: 1291/64

Type: Apartment Building

Stories: 6

Style: Neo-Romanesque

Date: 1928-30 [NB 2121-1928]

Architect: Prober & Blaufeux

Developer: T. & T. Construction Corp.

Built in 1928-30 to designs by Prober & Blaufeux, the six-story Eldorado Apartments is among the later apartment buildings erected in the historic district. Typical of that phase of development, it is a large building planned with a broad, shallow entrance court at its streetfront. The court is enclosed at the sidewalk by low brick walls with stone coping and is entered via a brick and stone gate.

The building's neo-Romanesque design is articulated by towers with open loggias, square turrets, battlements, pediments, and pitched tile roofs, creating a picturesque roofline; and the fanciful entrance gate with its squat columns, keyed stone arch, pitched tile roof, and small tower with a guard house. Other ornamental details include brick corbeling and banding; iron balconies; white stone window surrounds at the first story; stone stringcourses and sills; and randomly-placed quoins. The main entrance into the apartment building is surrounded by a stone arch. The door has been replaced, and a fixed awning has been added above it.

80TH STREET — West Side

80th Street between 34th Avenue and 35th Avenue (West Side)

34-28—34-50 80th Street

See: 34-27—34-49 79th Street

80th Street between 35th Avenue and 37th Avenue (West Side)

35-02 80th Street

See: 79-02—79-10 35th Avenue

80th Street between 35th Avenue and 37th Avenue (West Side)

35-16—35-54 80th Street

See: 35-15—35-55 80th Street

80th Street between 35th Avenue and 37th Avenue (West Side)

35-64 80th Street

See: 79-01—79-27 37th Avenue

80th Street between 37th Avenue and Roosevelt Avenue (West Side)

37-02—37-06 80th Street

See: 79-02—79-28 37th Avenue

80th Street between 37th Avenue and Roosevelt Avenue (West Side)

37-16—37-32 80th Street

See: 37-15—37-31 79th Street

80th Street between 37th Avenue and Roosevelt Avenue (West Side)

37-42—37-56 80th Street

See: 37-41—37-55 79th Street

81ST STREET — East Side

81st Street between Northern Boulevard and 34th Avenue (East Side)

33-53 81st Street

See: 81-01—81-11 34th Avenue

81st Street between 34th Avenue and 35th Avenue (East Side)

34-01 81st Street

See: 81-02—81-06 34th Avenue

81st Street between 34th Avenue and 35th Avenue (East Side)

MOUNT VERNON APARTMENTS

34-31 81st Street

Block/lot: 1268/51

Type: Apartment Building

Stories: 6

Style: Neo-Georgian

Date: 1935-36 [NB 4631-1935]

Architect: Cohn Brothers

Developer: Morris Goetz

Built in 1935-36 to designs by the Cohn Brothers, the six-story-and-basement Mount Vernon Apartments is among the later apartment buildings erected in the historic district. Typical of that phase of development, it is a large building on a mid-block site and planned with two recessed lightcourts which a break up the long street front into three sections, that at the center being the widest.

Neo-Georgian in style, the building is faced in red brick with white trim and is similar in its design to several other contemporary buildings by the Cohn Brothers firm within the historic district. Ornamental elements include brickwork imitating quoins; a monumental engaged colonnade applied to the upper stories at the center of the facade; brick courses suggestive of entablatures; projecting three-sided oriels; Palladian-inspired windows set into relieving arches; and, at the roofline, a pitched roof with gabled dormers, gable ends with chimneys, and brick pediments pierced by oculi.

The entrance surround has been altered and the entrance doors replaced. Balconettes have been removed from windows at the top story of the center section (the brackets remain). The chimney extension has been removed from the southern gable.

81st Street between 34th Avenue and 35th Avenue (East Side)

34-49 81st Street

See: 81-01—81-15 35th Avenue

81st Street between 35th Avenue and 37th Avenue (East Side)

35-01 81st Street

See: 81-02—81-10 35th Avenue

81st Street between 35th Avenue and 37th Avenue (East Side)

MAPLE COURT

35-21—35-27 81st Street
Block/lot: 1281/65

Type: Apartment Building
Stories: 6 with basement
Style: Art Deco

Date: 1930 [NB 1957-1930]
Architects: Ricca & Ungaleider
Developer: Polkmore Construction Corp.

Built in 1930 to designs by John M. Ricca of the firm of Ricca & Ungaleider, Maple Court is a large building on a mid-block site and is planned with two recessed lightcourts which break up the street front into three sections; the central section is about two-thirds the width of the end sections.

Characteristic of the Art Deco style, five-story brick pilasters terminating in stepped parapets create a vertical emphasis in the design of the facades. White cast-stone trim includes stepped corbels and triangular pediment forms with zigzag edges. Each court contains an entrance in a white cast-stone surround with a zigzag pediment, flanked by ribbed brick pilasters with stone caps; the metal lamps at the entrances are probably original, but the glass and metal doors are replacements. Some of the original six-over-six double-hung wood sash windows survive. Fixed awnings have been added at the entrances.

81st Street between 35th Avenue and 37th Avenue (East Side)

THE WAKEFIELD APARTMENTS

35-35—35-45 81st Street
Block/lot: 1281/54

Type: Apartment Building
Stories: 6 with basement
Style: Neo-Tudor

Date: 1937 [NB 1029-1937]
Architect: M.E. Ungaleider
Developer: Booth Realty

Built in 1937 to designs by M.E. Ungaleider, the six-story-and-basement Wakefield Apartments is among the later apartment buildings erected in the historic district. Typical of that phase of development, it is a large building on a mid-block site and planned with a deeply recessed lightcourt containing the entrance. Neo-Tudor in style, the brick facades of the building are ornamented with stone label lintels; random quoins; corner towerlettes with conical roofs; and pediments, crenelated parapets, and pitched overhangs at the roofline. The entrance is in a projecting, segmentally-arched surround of brick and cast-stone and surmounted by stone panel with Gothic motifs. The glass and metal entrance doors are replacements.

81st Street between 35th Avenue and 37th Avenue (East Side)

QUEENS BOROUGH PUBLIC LIBRARY — JACKSON HEIGHTS BRANCH

35-51 81st Street
Block/lot: 1281/48

Type: Library
Stories: 2
Style: International Style

Date: 1949-52 [NB 3703-1949]
Architect: S. Keller
Owner/Developer: City of New York

Built in 1949-52, the Jackson Heights Branch of the Queens Borough Public Library is a two-story International Style building designed by architect S. Keller. Since the 1920s, when a library was first established in Jackson Heights, the institution had occupied temporary quarters in various 37th Avenue storefronts. A neo-Georgian library designed by Sidney L. Strauss had been proposed in 1937, but it was never built.

The cast-stone and glass building occupies most of a large lot on the east side of 81st Street north of 37th Avenue. The asymmetrical, flat-roofed structure has a long, slightly recessed, north wing with banks of large rectangular windows in aluminum frames. The box-shaped entry pavilion, at the south, has a recessed bay containing glass and aluminum doors, transoms, and windows, flanked at the side by two vertical rows of small square windows. Above, raised metal letters identify the library.

Sources: Karatzas, 164-165; *Jackson Heights News*, May 1947, Sept. 1952, Aug. 1954, Oct. 1954.

81st Street between 35th Avenue and 37th Avenue (East Side)

35-59—35-61 81st Street

See: 81-01—81-19 37th Avenue

81st Street between 37th Avenue and Roosevelt Avenue (East Side)

37-01—37-09 81st Street

See: 81-02—81-10 37th Avenue

81ST STREET — West Side

81st Street between Northern Boulevard and 34th Avenue (West Side)

33-16—33-52 81st Street

See: 33-15—33-51 80th Street

81st Street between 34th Avenue and 35th Avenue (West Side)

34-02—34-48 81st Street

See: 34-01—34-47 80th Street

81st Street between 35th Avenue and 37th Avenue (West Side)

35-02 81st Street

See: 80-02—80-08 35th Avenue

81st Street between 35th Avenue and 37th Avenue (West Side)

THE FINCHLEY APARTMENTS

35-30 81st Street

Block/lot: 1280/12

Type: Apartment Building

Stories: 6

Style: Neo-Georgian (World War II era)

Date: 1940 [NB 5981-1939]

Architect: M.N. Weinstein

Developer: Colonial Gardens Inc.

Designed by M.N. Weinstein and built in 1940, the six-story Finchley Apartments is one of several apartment buildings constructed in the later era of development in Jackson Heights. Continuing the trend of the previous decade, it is a large building on a mid-block site and planned with three recessed lightcourts which break up the street front into four sections. The simple brick facades of the Finchley feature a modest application of Georgian-inspired ornamental details: stone and brick stringcourses, brick patterning suggesting quoins, arched stone window heads accenting several second-story windows, and roofline balustrades. The entrance is in the central lightcourt and is surrounded by a white cast-stone entryway with a segmental-arch opening, double pilasters, a frieze, and a dentiled broken pediment. The glass and metal doors are replacements. The original six-over-six double-hung wood sash windows survive; most window openings are divided by mullions into two- or three-part configurations.

81st Street between 35th Avenue and 37th Avenue (West Side)

BRENTWOOD HALL

35-50 81st Street

Block/lot: 1280/26

Type: Apartment Building

Stories: 6 with basement

Style: Modern

Date: 1950-51 [NB 2879-50]

Architect: Sohn & Weston

Developer: Versailles Gardens

Designed by Sohn & Weston and built in 1950-51, the six-story-and-basement apartment building known as Brentwood Hall is one of several apartment buildings constructed in the post-World War II era of development in Jackson Heights. Continuing the trend of the pre-War years, it is a large building on a mid-block site and is planned with two recessed lightcourts which break up its street front into three sections; the central section, where the entrance is located, is one-half the width of the end sections. The building's unadorned red brick facade is typical of the period, as are the wraparound window openings at the inner corners of the end sections. A rectangular surround of textured tile contains the glass and metal entrance doors.

81st Street between 35th Avenue and 37th Avenue (West Side)

35-64 81st Street

See: 80-01—80-29 37th Avenue

81st Street between 37th Avenue and Roosevelt Avenue (West Side)

37-06 81st Street

See: 80-02—80-28 37th Avenue

81st Street between 37th Avenue and Roosevelt Avenue (West Side)

THE JACKSONIAN APARTMENTS

37-20—37-22 81st Street

Block/lot: 1291/12

Type: Apartment Building

Stories: 6

Style: Neo-Romanesque

Date: 1927-28 [NB 6128-1927]

Architect: Seelig & Finkelstein

Developer: T. & T. Construction Corp.

Built in 1927-28 to designs by Seelig & Finkelstein, the six-story Jacksonian Apartments is a large building planned with an entrance court which breaks up the street front into two sections. Neo-Romanesque in style, the brick building is designed with decorative stonework, terra-cotta plaques and friezes, and a variety of brick patterns. At the roofline are corbel tables, a corbeled pediment above the entry court, and towers marked by engaged colonnettes at the corners. The towers are faced in a broad pattern of raised terra cotta and brick which creates a web of diamond and shell motifs suggestive of a Spanish-Romanesque *mudejar*. The entrance is located in a stone, terra-cotta and brick pavilion. The door surround has a foliate architrave and is flanked by brick piers to which are attached decorated stone colonnettes topped with lions. Above the door is a blind brick arcade and a geometric frieze. Iron fences and low brick walls flank the entrance to the court; iron balconies are located at the windows in the two towers (some have been removed); and there are fire escapes at the streetfront. The glass and metal entrance door is a replacement.

82ND STREET — East Side

82nd Street between Northern Boulevard and 34th Avenue (East Side)

LAUREL COURT

33-01 82nd Street (a/k/a 82-02—82-04 Northern Boulevard)—33-21 82nd Street
Block/lots: 1430/1, 59, 57, 55

33-01—33-05 82nd Street (a/k/a 82-02—82-04)
Northern Boulevard [1430/1]
33-11 82nd Street [1430/59]

33-17 82nd Street [1430/57]
33-21 82nd Street [1430/55]

Type: Apartment Buildings (4)
Stories: 5
Style: Edwardian

Date: 1913-14*
Architect: George H. Wells
Developer: Queensboro Corp.

*No. 33-01--33-05 82nd Street — NB 2239-1913

*Nos. 33-11, 33-17, and 33-21 82nd Street — NB 2240-1913

Designed by George H. Wells and built in 1913-14, the Laurel Court buildings are the earliest of the Queensboro Corporation's apartment buildings in Jackson Heights and the first of a group of early walk-up apartment buildings designed by the architect, predating the garden apartment complexes which appeared following World War I (the others are **Oban Court** and **Penryhn Court**, **The Colonial Apartments**, **Plymouth Court**, and **Willow Court**). The location of the four five-story buildings was chosen because of its proximity to the street-car stop at the corner of 82nd Street and Northern Boulevard. The building at the corner was planned with a long elevation along 82nd Street, where the residential entrance is located, and a storefront at the ground story of the Northern Boulevard frontage. The three buildings to the south face onto 82nd Street.

In style, the Laurel Court buildings draw on the neo-classical aesthetic of the Edwardian era in England. Faced in brick with stone trim, each building has a stone base with a classically-inspired entrance portico; the three southern buildings each have a projecting portico topped by a parapet with ironwork. Above are single and tripartite bays with keyed enframements and slightly protruding, metal-clad three-sided oriels. Bandcourses, brick panels and parapets, and cornices highlight the top story of each building; the original cornice survives only at the Northern Boulevard facade of the northernmost building. Original wood and glass double-doors with transoms covered by iron grilles survive at Nos. 33-11 and 33-21. The spandrels of the oriels at No. 33-11 are covered with metal panning. Original multi-pane-over-one windows survive at No. 33-21.



Laurel Court

Block 1430 Lots 1, 55, 57 & 59

33-01—33-05 82nd Street, a.k.a. 82-02—82-04 Northern Boulevard

[1430/1]

33-11 82nd Street
[1430/59]

33-17 82nd Street
[1430/57]

33-21 82nd Street
[1430/55]

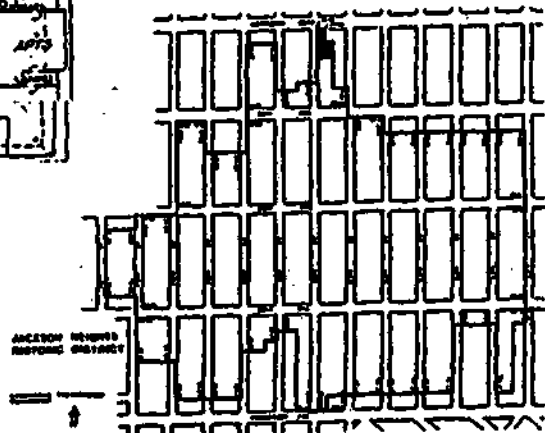
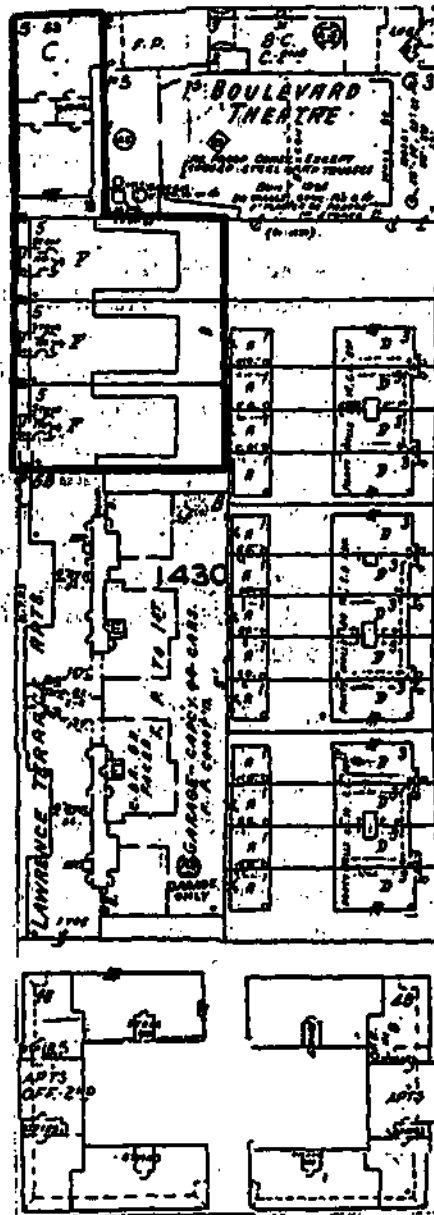

82nd Street between Northern Boulevard and 34th Avenue (East Side)

LAWRENCE TERRACE APARTMENTS

33-33 82nd Street

Block/lot: 1430/43

Type: Apartment Building

Stories: 6

Style: Neo-Georgian (post-World War II)

Date: 1950-51 [NB 5305-1950]

Architect: Philip Birnbaum

Developer: Lawrence House, Inc.

Designed by Philip Birnbaum and built in 1950-51, the six-story Lawrence Terrace Apartments is one of several apartment buildings constructed in the post-World War II era of development in Jackson Heights. Continuing the trend of the pre-War years, it is a large building planned with two broad lightcourts which divide the streetfront into three sections. A vehicular door at the northernmost section leads to a garage at the rear.

Like many Jackson Heights apartment buildings of the 1950s, Lawrence Terrace has a simple red brick facade featuring a modest application of Georgian-inspired ornamental details, limited to the central pedimented entrance portico, the two oval windows flanking the portico, and header brick band courses at the base and top. The entrance doors are replacements and an awning has been installed above the entry.

82nd Street between Northern Boulevard and 34th Avenue (East Side)

HAYES COURT

33-53 82nd Street (a/k/a 82-01 34th Avenue) and 33-54 83rd Street

Block/lots: 1430/35, 29

33-53 82nd Street (a/k/a 82-01 34th Avenue)
[1430/35]

33-54 83rd Street [1430/29]

Type: Garden Apartments (2 buildings)

Stories: 4 with basement

Style: Neo-French Renaissance

Date: 1922-23 [NB 1376-1922]

Architect: Andrew J. Thomas

Developer: Hayes Ave. Apt. Co.

Hayes Court, built in 1922-23, is one of three Jackson Heights garden apartments designed by Andrew J. Thomas to be built on end-block sites in the 1920s (see *Ivy Court* and *Cedar Court*). Smaller in comparison to the whole-block complexes elsewhere in the district, Hayes Court consists of two U-shaped buildings, each with four stories and a basement, with the open ends facing each other and framing an interior garden. Small front gardens line all three street frontages.

Inspired by the French Renaissance style, the buildings are designed with brick facades laid in Flemish bond and are crowned by imposing slate mansard roofs with dormers, chimneys, and finials. At the center of each of the street facades on 82nd and 83rd streets are projecting pavilions, enhanced by brick diaperwork at the third story and taller roof sections. At the base of each pavilion is an arched stone portal, surmounted by a stone shield. The portals provide entry to vaulted passageways leading through the building and into the garden. Stone balconettes with elaborate ironwork are located at the end bays of the second story on each facade.

The interior facades, which are partially visible from all three streets, are similar in detail to the outer facades. The interior garden, which occupies a large part of the site, is visible in part from outside the complex through gates, consisting of brick pedestals and iron fences, which span the area between the buildings on 34th Avenue, and through the arched passageways on the side streets.

Alterations include the replacement of retaining walls and fences enclosing the front gardens, the addition of concrete and brick ramps leading to new openings serving doctors' offices at the first story, and the installation of awnings. Multi-pane double-hung sash windows have been retained in the stairhalls.



Hayes Court

Block 1430 Lots 29 & 35

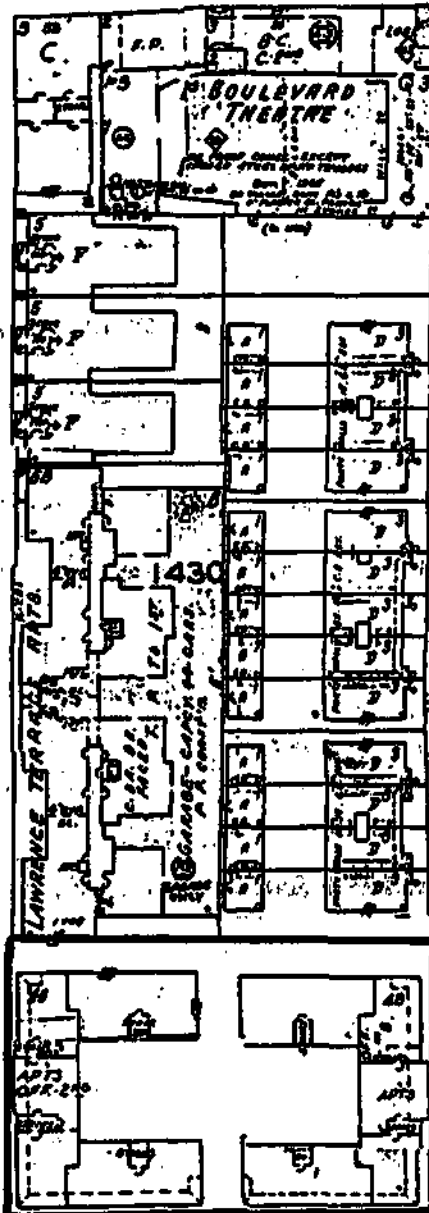

33-53 82nd Street

[1430/35]

33-54 83rd Street

[1430/29]

a.k.a. 82-01 34th Avenue

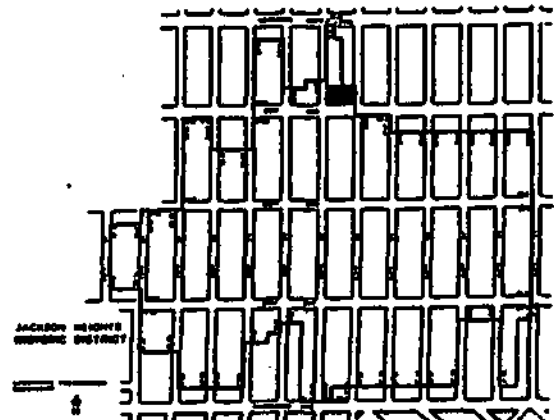

82nd Street — East Side

82nd Street between 34th Avenue and 35th Avenue (East Side)

34-01 82nd Street

See: 82-02—82-20 34th Avenue

82nd Street between 34th Avenue and 35th Avenue (East Side)

THE JEWISH CENTER OF JACKSON HEIGHTS

34-25 82nd Street (a/k/a 34-24 83rd Street)

Block/lot: 1443/19

Type: Synagogue

Stories: 3

Style: International Style

Date: 1959-60 [NB 3922-1958];

addition 1968-69 [Alt 577-1968]

Architect: Bloch & Hesse; addition, J. Stein

Developer: Jewish Center of Jackson Heights

Located on 82nd Street near the 34th Avenue end of the block, the Jewish Center of Jackson Heights was constructed in two sections: the first section was built in 1959-60 to designs by Bloch & Hesse, a firm which specialized in synagogues, and in 1968-69 a large addition was built to designs by J. Stein on the north side of the original building.

The International Style building has complex massing, with brick sections of various heights, including a four-story block with a windowless facade facing 82nd Street and ribbon windows on the other elevations. The low, north wing of the building has a semi-circular facade with narrow vertical window openings. The site extends through the block to a narrow parking lot on 83rd Street, enclosed by a chain-link fence.

82nd Street between 34th Avenue and 35th Avenue (East Side)

COLONIAL APARTMENTS

34-31—34-51 82nd Street

Block/lots: 1443/57, 55, 53, 51, 49, 47

34-31 82nd Street [1443/57]

34-35 82nd Street [1443/55]

34-39 82nd Street [1443/53]

34-43 82nd Street [1443/51]

34-47 82nd Street [1443/49]

34-51 82nd Street [1443/47]

Type: Apartment Buildings (6)

Stories: 5 with basement

Style: Neo-Georgian

Date: 1915-16 [NB 4323-1915]

Architect: George H. Wells

Developer: Roosevelt Ave. Building Co. Inc.

The Colonial Apartments, built in 1915-16, comprise one of the early apartment building complexes in Jackson Heights designed by George H. Wells. Like that architect's other early walk-up apartments (**Laurel Court, Oban Court and Penryhn Court, Plymouth Court, and Willow Court**), the Colonial Apartments were built near the street-car stop at 82nd Street and Northern Boulevard. The complex consists of six identical five-story-and-basement buildings.

Designed in the neo-Georgian style, the Colonial Apartments are clad in red brick laid in Flemish bond and trimmed with white stone keystones and panels with ornamental swags. The modillioned cornices are topped with balustrades. Each building has a projecting entrance portico, a hallmark of Wells's work. Each brick and stone portico has a round-arched doorway flanked by columns supporting an entablature and an iron balustrade. The original wood and glass double-doors with iron grilles, as well as the fanlight transoms, survive intact. Some of the original six-over-one wood sash windows survive, as do the all of the double-hung windows with leaded sash located in the central stairhall bay of each building. The fence enclosing the front gardens at No. 34-43 appears to be original.



Colonial Apartments

Block 1433 Lots 47, 49, 51, 53, 55 & 57

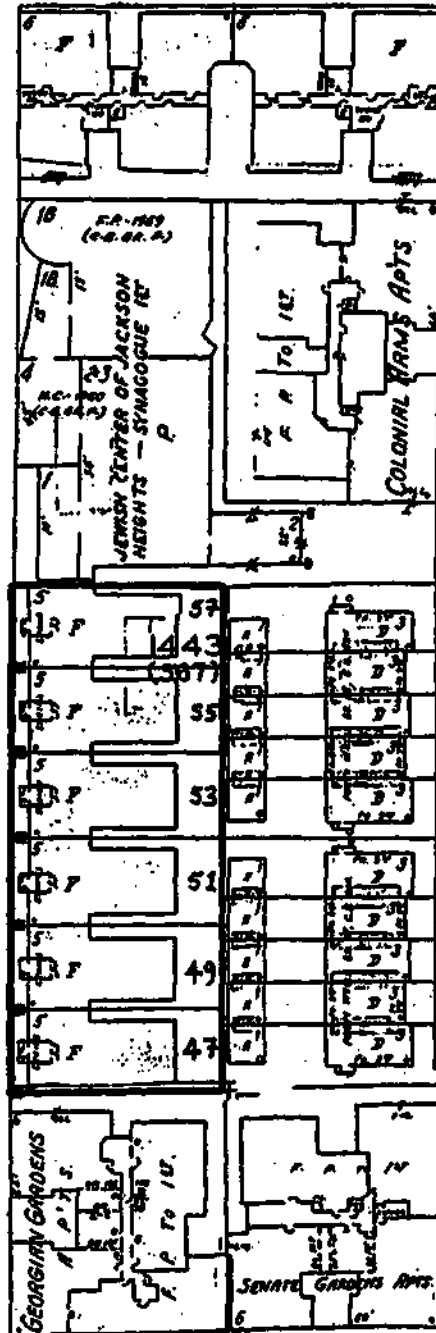

[1433-57] 34-31 82nd Street

[1433/55] 34-35 82nd Street

[1433/53] 34-39 82nd Street

[1433/51] 34-43 82nd Street

[1433/49] 34-47 82nd Street

[1433/47] 34-51 82nd Street

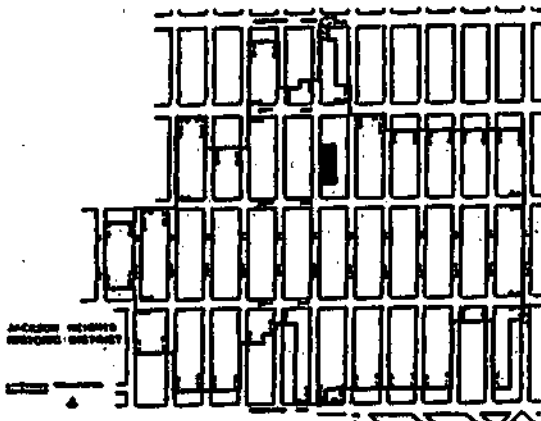

82nd Street between 34th Avenue and 35th Avenue (East Side)

GEORGIAN GARDENS

34-57 82nd Street (a/k/a 82-01 35th Avenue)

Block/lot: 1443/40

Type: Apartment Building

Stories: 6 with basement

Style: Neo-Georgian

Date: 1935-36 [NB 4594-1935]

Architect: Cohn Brothers

Developer: Three Star Invest Co.

Built in 1935-36 to designs by the Cohn Brothers, the six-story-and-basement Georgian Gardens is among the later apartment buildings erected in the historic district. Typical of that phase of development, the building occupies an end-block site on 35th Avenue and is planned with a large, recessed entrance court at the front (oriented toward 82nd Street).

Neo-Georgian in style, the building is faced in red brick with white trim and is similar in its design to the **Colonial Arms at 34-20 83rd Street**, designed by the Cohn firm in 1935, as well as to the adjacent building, the **Senate Gardens at 82-15 35th Avenue**, designed by Seelig & Finkelstein in 1937. Ornamental elements include the door surround with fluted pilasters and a broken pediment; brickwork imitating quoins and brick pilasters with stone bases and stylized stone capitals; brick bandcourses suggestive of entablatures; windows set into relieving arches with stone keystones; and, at the roofline, parapet balustrades, decorative urns, and brick pediments pierced by oculi or by an arched opening with a balconette (on 35th Avenue).

Alterations include the replacement of entrance doors; the addition of a concrete, brick, and steel ramp leading to a professional office installed on 35th Avenue; and the removal of balconettes from two second-story bays on 35th Avenue (the brackets remain).

82nd Street between 35th Avenue and 37th Avenue (East Side)

SAINT JOAN OF ARC R.C. CHURCH COMPLEX

See: 35th Avenue between 82nd and 83rd Streets (South Side)

82nd Street between 35th Avenue and 37th Avenue (East Side)

WILLOW COURT

35-35—35-45 82nd Street

Block/lots: 1456/56, 52

35-35 82nd Street [1456/56]

35-45 82nd Street [1456/52]

Type: Apartment Buildings (2)

Stories: 5 with basement

Style: Edwardian

Date: 1915*

Architect: George H. Wells

Developer: Roosevelt Ave. Bldg. Co. Inc.

*No. 35-35 82nd Street — NB 1864-1915

*No. 35-45 82nd Street — NB 1865-1915

Willow Court, built in 1915, is one of the early apartment building complexes in Jackson Heights designed by George H. Wells. Like that architect's other early walk-up apartments (**Laurel Court**, **Plymouth Court**, **Oban Court** and **Penryhn Court**, and **The Colonial Apartments**), Willow Court was

built near the street-car stop at 82nd Street and Northern Boulevard. The complex consists of two identical five-story-and-basement buildings, faced in brick with stone trim. The Willow Court buildings have large lightcourts at the sides and were planned to occupy only 58 percent of their lots, as opposed to the more common 70 percent then allowed by law, and thus they represented an important step toward the Queensboro Corporation's development of the garden apartment in Jackson Heights.

The style of Willow Court is derived from the neo-classical aesthetic of the Edwardian era in England. The facades are Roman brick above a stone base, and enlivened with such elements as classically-inspired entrance surrounds with large bracketed pediments; splayed stretcher brick lintels and stone sills; keyed window enframements and brick panels at the top story; and, at the roofline, modillioned cornices and arcaded parapets. The fire escapes have decorative ironwork. The original glass and metal double doors with transoms survive.

82nd Street between 35th Avenue and 37th Avenue (East Side)

WEST GATE and EAST GATE

35-51—35-55 82nd Street and 35-54—35-56 83rd Street
Block/lots: 1456/29 and 46

35-51—35-55 82nd Street [1456/46]

35-54—35-56 83rd Street and [1456/29]

Type: Apartment Buildings (2)
Stories: 6 with basement
Style: Neo-Tudor

Date: 1937*
Architect: Miller & Goldhammer
Developer: 82-83 St. Corp.

*No. 35-51--35-55 82nd Street — NB 616-1937

*No. 35-54--35-56 83rd Street — NB 179-1937

Built in 1937 to designs by Miller & Goldhammer, the six-story-and-basement West Gate and East Gate Apartments are among the later apartment buildings erected in the historic district. Typical of that phase of development, the two, almost identical, buildings occupy back-to-back mid-block sites on 82nd Street (West Gate) and 83rd Street (East Gate). Each is a large building planned with a recessed entrance court which serves as a lightcourt that breaks up the street front into two sections.

Neo-Tudor in style, the brick buildings are trimmed with stone details. Elements typical of that style include Tudor-arch entrance surrounds, label lintels and keyed window enframements, peaked gable forms, stone bandcourses with carved quatrefoils and other plaques, pointed-arch balustrades framing the entry courts, and random stone quoins set in the brickwork. Characteristic of the period, the buildings also have corner windows and stepped parapets. There are fire escapes with decorative ironwork in the light wells.

82nd Street between 37th Avenue and Roosevelt Avenue (East Side)

37-01—37-09 82nd Street

See: 82-02—82-10 37th Avenue

82nd Street between 37th Avenue and Roosevelt Avenue (East Side)

37-11—37-39 82nd Street
Block/lot: 1470/59

Type: Commercial Building
Stories: 2
Style: Neo-Tudor

Date: 1935; 1938-39 [NB 167-1935;
NB 1014-1938]
Architect: Simon B. Zelnik
Developer: Sanline Realty Corp.

Built in two sections in 1935 and 1938-39 to designs by Simon B. Zelnik, this building is one of a cluster of neo-Tudor buildings which survive at or near the intersection of 82nd Street and 37th Avenue, the historic district's two commercial thoroughfares. The other structures are the stores at **82-02—82-10 37th Avenue** abutting it to the north, and the (former) **Queensboro Corporation Headquarters and English Gables** on the west side of 82nd Street.

Records of the Queens Department of Buildings suggest that this building was constructed in two sections: the first application [167-1935] specified a structure with a frontage of 193 feet to house "stores and a motion picture theatre" and the second application [NB 1014-1938] specified a structure with a frontage of 100 feet for "stores." A 1935 rendering of the proposed "English Gables II" corresponds to the earlier, northern portion of the building as it exists today.

This long, two-story building is punctuated by three peaked, stone-faced gables and topped by a continuous pitched slate roof. (Originally a fourth gable was visible; it may survive behind the double-height storefront facade at No. 37-19.) At the second story, the end gables have triple windows with multi-pane casement sash, topped by label lintels. The middle gable has a three-sided oriel window. The remainder of the second story, faced in brick, is set back slightly between the gables and behind a stone parapet accented with terra-cotta panels. Multi-pane windows survive at the second story. The stone facing has been painted.

At the ground story, a stone stringcourse sets off the fascia, which is visible behind more recent signage. The Colony Theater at No. 37-29 is marked by a raised parapet with battlements and retains a projecting metal-trimmed marquee. All of the historic storefronts below the fascia have been replaced. Located on the same tax lot [Lot 59] is the one-story commercial structure at No. 37-11--37-13 which appears to be a later addition.

Source: Karatzas, 136, 138.

82nd Street between 37th Avenue and Roosevelt Avenue (East Side)

37-41—37-45 82nd Street
Block/lot: 1470/56

Type: Commercial Building

Date: 1986-87 [ALT 736-1986]
Developer: Louis A. Caporale

A one-story commercial structure designed by Simon B. Zelnik was built on this site in 1935 [NB 3495-1935]; in 1986-87 it was completely gutted and rebuilt.

82nd Street between 37th Avenue and Roosevelt Avenue (East Side)

37-47—37-59 82nd Street

Block/lots: 1470/55, 54, 53, 52, 51, 50, 49

37-47 82nd Street [1470/55]

37-49 82nd Street [1470/54]

37-51 82nd Street [1470/53]

37-53 82nd Street [1470/52]

37-55 82nd Street [1470/51]

37-57 82nd Street [1470/50]

37-59 82nd Street [1470/49]

Type: Commercial Buildings
(7 rebuilt rowhouses)

Stories: 2

Style: Vernacular, Neo-Georgian, Neo-Tudor

Date: 1911 [NB 1016-1911];
later alterations*

Architect: Charles Peck [1911]

Developer: Charles E. Currier Co. Inc.

**alterations*

No. 37-47 82nd Street — [Alt 1657-1941]

No. 37-49 82nd Street — [Alt 9704-1937]

No. 37-51 82nd Street — [Alts 10330-1936;
526-1937]

No. 37-53 82nd Street — [Alt 3286-1947]

No. 37-55 82nd Street — [Alts 7482-1933;
1116-1939]

No. 37-57 82nd Street — [Alt 793-1955]

No. 37-59 82nd Street — [Alts 865-1928;
938-1942]

These seven buildings were originally built in 1911 as part of a row of ten two-story houses and rebuilt for commercial use in the 1930s, '40s, and '50s. They are located back-to-back with a row of unaltered houses on 83rd Street, designed by the same architect, Charles Peck, and built at the same time (see 37-46—37-60 83rd Street). All of the buildings on 82nd Street were extended to the lot line at the front and given new facades for commercial use. Above the ground-story storefronts, the facades are generally brick (37-51, 37-53, 37-55, 37-57, 37-59) or cast-stone (37-47, 37-49 [remnants]). The upper facades frame large windows in either paired or tripartite configurations and feature minimal embellishment: rustication and a classical medallion (No. 37-47); fluted end piers (No. 37-49); decorative brickwork including stretcher courses and paneled parapets (Nos. 37-51, 37-57, and 37-59); neo-Georgian-inspired decorative brickwork, keystones, and a pent roof (No. 37-53); and Tudor-inspired terra-cotta turret-like forms (No. 37-55). All of the first-story storefronts have been subsequently altered.

82nd Street between 37th Avenue and Roosevelt Avenue (East Side)

37-61—37-67 82nd Street

See: 82-01—82-19 Roosevelt Avenue

82ND STREET — West Side

82nd Street between Northern Boulevard and 34th Avenue (West Side)

33-50 82nd Street

See: 81-01—81-11 34th Avenue

82nd Street between 34th Avenue and 35th Avenue (West Side)

34-02—34-06 82nd Street

See: 81-14—81-20 34th Avenue

82nd Street between 34th Avenue and 35th Avenue (West Side)

ALLENDALE APARTMENTS

34-20—34-24 82nd Street

Block/lot: 1268/13

Type: Apartment Building

Stories: 6 with basement

Style: Neo-Georgian

Date: 1937 [NB 1329-1937]

Architect: Joshua Tabatchnik

Developer: Allendale Construction Corp.

Built in 1937 to designs by Joshua Tabatchnik, the six-story-and-basement Allendale Apartments is among the later apartment buildings erected in the historic district. Typical of that phase of development, the building occupies a large mid-block site and is planned with two lightcourts which break up the long street front into three sections. The widest section, at the center, has a shallow recess where the entrance is located, flanked by full-height three-sided bays; each lightcourt has a similar bay.

Designed in the neo-Georgian style, the building is similar to a number of other contemporary buildings in the historic district. Elements which are typical of the style include brickwork imitating quoins; monumental brick pilasters with stone trim, applied to the upper facade; brick dentil courses and entablatures; tripartite Palladian-inspired windows set into relieving arches composed of brick headers; gables with oculi at the roofline; and parapet balustrades. Niches flanking the entrance contain urns.

A few original multi-pane wood windows survive at the basement level. The entrance doors have been replaced.

82nd Street between 34th Avenue and 35th Avenue (West Side)

THE DELANO

34-44 82nd Street

Block/lots: 1268/1000-1052

Type: Apartment Building

Stories: 6 with basement

Style: Neo-Georgian

Date: 1937 [NB 578-1937]

Architect: Cohn Brothers

Developer: Delano Building Co.

Built in 1937 to designs by the Cohn Brothers, the six-story-and-basement Delano Apartments is among the later apartment buildings erected in the historic district. Typical of that phase of development, the building occupies a large mid-block site and has a deep entrance court which breaks up its street front

into two sections. The main entrance is set into a full-height three-sided bay. The building is similar in design to a number of other buildings in the district produced by the Cohn Brothers firm.

Faced in red brick with white trim, the building is neo-Georgian in style. Elements which are typical of the style include the projecting entrance containing a door surround of engaged columns supporting an entablature with a broken pediment; the windows with multi-pane arched sash flanking the entrance; brickwork imitating quoins and brick and stone band courses; relieving arches with brick headers; stone keystones; small oval windows; monumental brick pilasters supporting an architrave; and pediment motifs at the roofline (the parapet has been rebuilt and the projecting portions of the pediments have been removed). The double-leaf wood-and-glass doors are surmounted by a transom. Brick pedestals and iron fences span the entrance to the court.

82nd Street between 35th Avenue and 37th Avenue (West Side)

35-02 82nd Street

See: 81-02--81-10 35th Avenue

82nd Street between 35th Avenue and 37th Avenue (West Side)

PLYMOUTH APARTMENTS

35-16--35-30 82nd Street

Block/lots: 1281/13, 17, 18, 24

35-16 82nd Street [1281/13]

35-20 82nd Street [1281/17]

35-26 82nd Street [1281/18]

35-30 82nd Street [1281/24]

Type: Apartment Buildings (4)

Stories: 5 with basement

Style: Edwardian.

Date: 1916 [NB 847-1916]

Architect: George H. Wells

Developer: Jackson Heights Apt. Corp.

The Plymouth Apartments, built in 1916, is one of the early apartment building complexes in Jackson Heights designed by George H. Wells. Like that architect's other early walk-up apartments (**Laurel Court, Oban Court and Penryhn Court, The Colonial Apartments, and Willow Court**), the Plymouth was built near the street-car stop at 82nd Street and Northern Boulevard. The complex consists of four identical five-story-and-basement buildings, faced in brick with stone trim. The Plymouth buildings were planned to occupy only 58 percent of their lots, as opposed to the more common 70 percent then allowed by law, and thus they represented an important step toward the Queensboro Corporation's development of the garden apartment in Jackson Heights.

In style, the Plymouth Apartments draw on the neo-classical aesthetic of the Edwardian era in England. The buildings bear a striking resemblance to a six-story apartment building at 12 Hyde Park Place in London built in 1902-03, just a decade earlier, to designs by Frank T. Verity. Though somewhat modest by comparison, the Plymouth Apartments share with its English predecessor a modified pavilion plan, large windows, rusticated banding, and a projecting cornice topped by a parapet. The metal fire escapes on Wells's buildings are even somewhat suggestive of the iron balconies of Verity's building, as are the projecting central entry porches, each of which has stone Doric columns supporting an entablature and an eared door surround. Projecting porches became a hallmark of Wells's subsequent work in Jackson Heights. Other ornamental details on the buildings include bracketed cornices, swags on the parapets, stone lintels and sills, and brick panels between the fifth-story windows. Some of the original six-over-one double-hung wood sash windows survive, as do the glass and metal entrance doors with transoms.

Source: Alastair Service, *Edwardian Architecture and its Origins*, 449.

82nd Street between 35th Avenue and 37th Avenue (West Side)

STEPHEN HALL APARTMENTS

35-36—35-42 82nd Street
Block/lot: 1281/25

Type: Apartment Building
Stories: 6
Style: Neo-Georgian

Date: 1936 [NB 4322-1936]
Architect: Kavy & Kavovitt
Developer: 35-40 82nd Street Corp.

Built in 1936, the six-story Stephen Hall Apartments and its similar neighbor at **35-50 82nd Street** (see) were designed by Kavy & Kavovitt for the same developer. The buildings are among the later apartment buildings erected in the historic district. Typical of that phase of development, Stephen Hall is a large building on a mid-block site and planned with a recessed entrance court which serves as a lightcourt and breaks the street front into two sections. Neo-Georgian in style, the red brick facade of the building is trimmed with white stone detail. The face of each section has a brick and stone temple-front motif at the upper stories, with brick pilasters supporting a triangular pediment containing an oculus and swags. Other elements typical of the neo-Georgian style are the brickwork simulating quoins; brick stringcourses; blind arches at window heads; and such stone accents as keystones, dentils, and moldings. Sloping brick walls form the gateway to the entrance court. The projecting entrance portico has a pitched roof; flanking paired pilasters of wood; and wood, metal and glass double doors with a fanlight transom. Fixed awnings have been added above doorways in the street fronts.

82nd Street between 35th Avenue and 37th Avenue (West Side)

35-50 82nd Street
Block/lot: 1281/33

Type: Apartment Building
Stories: 6
Style: Neo-Georgian

Date: 1936-37 [NB 5521-1936]
Architect: Kavy & Kavovitt
Developer: 35-40 82nd Street Corp.

Built in 1936-37, the six-story building at 35-50 82nd Street and its neighbor, the **Stephen Hall Apartments** (see) were designed by Kavy & Kavovitt for the same developer. The buildings are among the later apartment buildings erected in the historic district. No. 35-50, the smaller and slightly later building of the two, continues the facade design of Stephen Hall. Neo-Georgian in style, the red brick facade of the building is trimmed with white stone detail. The upper facade has a brick and stone temple-front motif, with brick pilasters supporting a triangular pediment containing an oculus and swags. Other elements typical of the neo-Georgian style are the brickwork simulating quoins; brick stringcourses; and such stone accents as splayed lintels, keystones, dentils, and moldings. The arched entrance contains a wood and glass door with flanking panels and sidelights, similar to the main doors of the Stephen Hall Apartments. A fixed awning has been added above the entrance. A balcony has been removed from the center bays of the third story, although the brackets remain.

82nd Street between 35th Avenue and 37th Avenue (West Side)

35-60 82nd Street
See: 81-01—81-19 37th Avenue

82nd Street between 37th Avenue and Roosevelt Avenue (West Side)

37-02—37-10 82nd Street

See: 81-14—81-28 37th Avenue

82nd Street between 37th Avenue and Roosevelt Avenue (West Side)

ENGLISH GABLES

37-12--37-34 82nd Street

Block/lot: 1292/12

Type: Commercial Building

Stories: 2

Style: Neo-Tudor

Date: 1928 [NB 344-1928]

Architect: Robert Tappan

Developer: Queensboro Corp.

Built 1928 to designs by Robert Tappan, English Gables is one of a cluster of neo-Tudor commercial buildings which survive at or near the intersection of 82nd Street and 37th Avenue, the historic district's two commercial thoroughfares. The other structures are the (former) **Queensboro Corporation Headquarters** abutting it to the north, and the stores at **82-02—82-10 37th Avenue** and **37-11--37-39 82nd Street** on the east side of 82nd Street. Architect Robert Tappan was also responsible for several of the rows of attached and semi-detached houses in the historic district.

The two-story, 240-foot long building is punctuated by seven peaked gables and topped by a continuous pitched slate roof. Each end of the building has a gabled brick pavilion with a projecting three-sided oriel; a pair of gabled and half-timbered oriels flanks each side of a flat, stone-faced gable at the center of the long facade. Between each end pavilion and the center gables, the second story of the facade is half-timbered and recessed behind stone balustrades. Prominent chimneys and stone quoins, keys, niches, and window surrounds further enhance the design. Multi-pane casement windows survive in the second-story windows.

At the ground story the stone fascia above the storefronts is visible behind more recent signage. All of the historic storefronts below the fascia have been replaced. At the central, stone-faced section of the facade, the arched, carved stone entrance to the building is partially visible behind signage.

82nd Street between 37th Avenue and Roosevelt Avenue (West Side)

37-36—37-40 82nd Street

Block/lots: 1292/24, 26

Type: Commercial Building

Stories: 2

Style: Neo-Tudor

Date: 1928-29 [NB 8026-1928]

Architect: Boris Dorfman

Developer: Prudential Associates, Inc.

This two-story building (situated on two tax lots), built in 1928-29 and designed by Boris Dorfman, is characteristic of the commercial development that occurred along this section of 82nd Street near the elevated train station. The building's stylized neo-Tudor facade design survives in the channeled brick piers and spandrels framing the second-story windows. The pitched roof (now resurfaced) was originally covered with multi-colored slate shingles. The second story has been partly resurfaced with corrugated metal and signage. Some historic storefront elements survive, such as glass and aluminum vitrines, bulkheads, and paving at the central storefront (No. 37-38).

82nd Street between 37th Avenue and Roosevelt Avenue (West Side)

37-42—37-50 82nd Street
Block/lots: 1298/28, 31

37-42—37-46 82nd Street [1298/28]

37-50 82nd Street [1292/31]

Type: Commercial Buildings
Stories: 2

Date: alterations 1986 [BN 1040-1986]

In the late 1920s, two two-story commercial buildings were constructed on this site: one designed by Murray Klein [NB 4458-1928] and the other by M.A. Cantor [NB 3811-1929]. The buildings have been substantially altered since that time and at present they are configured as three commercial spaces. The stores at each end were resurfaced with metal fronts as recently as 1986, though the storefront at the middle appears to date from an earlier alteration.

82nd Street between 37th Avenue and Roosevelt Avenue (West Side)

37-52—37-58 82nd Street
Block/lot: 1292/32

Type: Commercial Building
Stories: 2
Style: Neo-Tudor

Date: 1930-31 [NB 6001-1930]
Architect: M. Hirsch
Developer: Philip Gottfried

This two-story building, constructed in 1930-31 and designed by M. Hirsch in the neo-Tudor style, is characteristic of the commercial development that occurred along this section of 82nd Street near the elevated train station. At the second story, the facade is articulated by decorated brick panels and bands framing large tripartite windows. The parapet is adorned with small terra-cotta turrets and blind Gothic arches. Below the fascia, which is mostly obscured by large signs, all of the original storefronts have been replaced.

82nd Street between 37th Avenue and Roosevelt Avenue (West Side)

37-60 82nd Street
Block/lot: 1292/36

Type: Flats with store
Stories: 4
Style: Neo-Tudor

Date: 1928 [NB 2947-1928]
Architect: R. Lukowsky
Developer: Hallus Realty Co.

Built in 1928, this four-story flats building with a ground-story store has a neo-Tudor facade which is similar in style to several of the commercial buildings on this block of 82nd Street. The brick facade has keyed stone window surrounds at the upper stories, pseudo-gables at the roofline, and a pent roof. The original storefront has been replaced.

82nd Street between 37th Avenue and Roosevelt Avenue (West Side)

37-66 82nd Street

Block/lot: 1292/40

Type: Commercial Building

Stories: 2

Style: Modern Classical

Date: 1927-28 [NB 15317-1927]

Architect: Jack Z. Cohen

Developer: Undetermined

This two-story building, constructed in 1927-28 and designed by Jack Z. Cohen, is characteristic of the commercial development that occurred along this section of 82nd Street near the elevated train station. The cast-stone facade uses the same material as the adjoining bank, constructed a few years earlier (see **Corn Exchange Bank, 81-11—81-19 Roosevelt Avenue**), and continues that building's overall proportions and Modern Classical style. The simple facade has broad, four-part double-hung windows with transoms at the second story and incorporates such neo-classical details as window mullions with abstract capitals, stylized entablatures above both stories, and a bracketed and paneled door surround at the entrance. A stepped parapet with cast-stone coping crowns the facade. Below the first-story entablature, all of the storefronts have been replaced.

82nd Street between 37th Avenue and Roosevelt Avenue (West Side)

37-68—37-80 82nd Street

See: 81-11—81-19 Roosevelt Avenue

83RD STREET — East Side

83rd Street between 34th Avenue and 35th Avenue (East Side)

IVY COURT

34-01—34-09 83rd Street (a/k/a 83-02 34th Avenue) and 34-02—34-10 84th Street (a/k/a 83-16 34th Avenue)

Block/lots: 1444/1, 6

34-01—34-09 83rd Street
(a/k/a 83-02 34th Avenue) [1444/1]

34-02—34-10 84th Street
(a/k/a 83-16 34th Avenue) [1444/6]

Type: Garden Apartments (2 buildings)
Stories: 4 with basement
Style: Neo-Romanesque

Date: 1924*
Architect: Andrew J. Thomas
Developer: Hayes Ave. 26 St. Corp.

*No. 34-01—34-09 83rd Street — NB 404-1924

*No. 34-02—34-10 84th Street — NB 403-1924

Built in 1924, Ivy Court is one of three smaller garden apartment projects designed by Andrew J. Thomas in the mid-1920s and built on end-block sites (see **Hayes Court** and **Cedar Court**). At Ivy Court, the two U-shaped, four-story-and-basement brick buildings are arranged around an inner garden courtyard. The entrances to the buildings are within the courtyard which is entered via barrel-vaulted passageways in the side street facades on 83rd and 84th Streets. Small gardens line the sidewalks.

The style of Ivy Court continues the Mediterranean-inspired, neo-Romanesque design of the slightly-earlier **Towers** (see), one of Thomas's much larger complexes of the same period. Each side street facade is massed with arcaded towers flanking open loggias and the avenue facades have towered stairhall bays; the roofline is further enhanced by Spanish-tile roofs. At the ground story of each of the side street facades is a stone archway with carved reveals marking the barrel-vaulted passageway. Other decorative elements of the design include blind brick arcades at the fourth story; stone plaques; the stone bases of balconettes at the side-street towers (the balusters, probably iron, have been removed); and decorative brick band courses. Original six-over-six double-hung wood windows survive in the stairhall bays.

The inner facades of Ivy Court continue the style of the street facades; those facades, as well as the large inner garden, are partially visible from the sidewalks outside the complex through the arched passageways and through the opening at 34th Avenue which separates the two buildings. That opening is spanned by a pipe-rail fence, beyond which an areaway between the buildings drops in grade to basement level. Chain-link fencing has been added at the sidewalks and in the courtyard.



Ivy Court

Block 1444 Lots 1 & 6

34-01 83rd Street

[1444/1]

34-09 83rd Street

34-02 84th Street

[1444/6]

34-10 84th Street

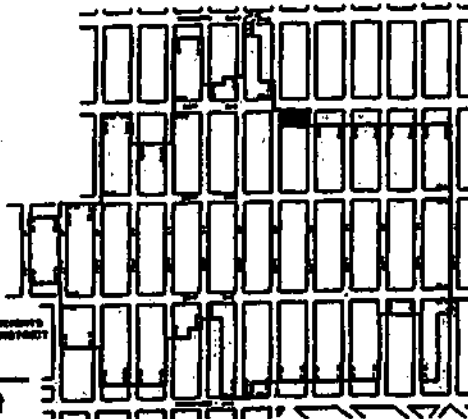
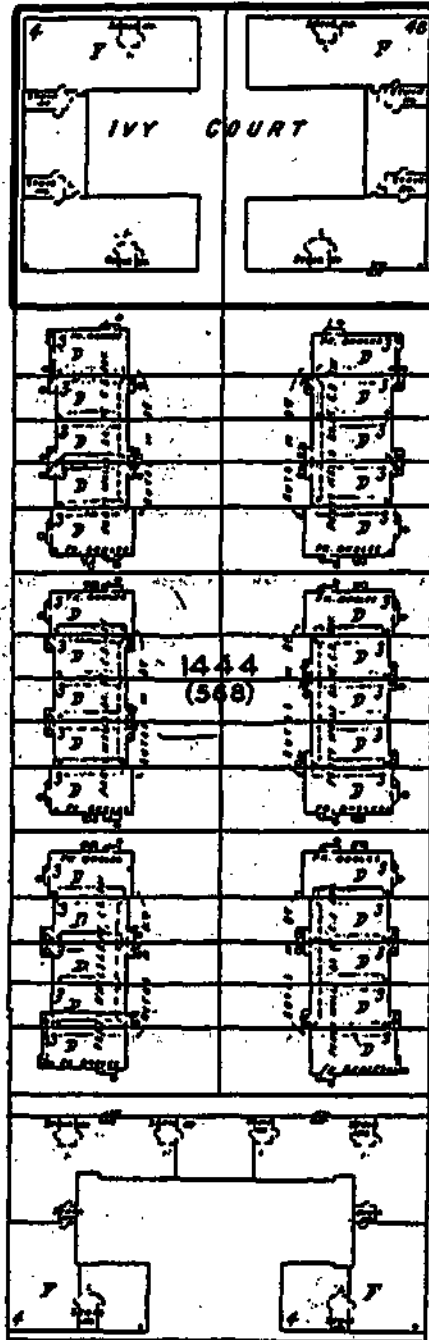

JACKSON HEIGHTS HISTORIC DISTRICT

83rd Street between 34th Avenue and 35th Avenue (East Side)

PLYMOUTH HOUSES

34-15—34-51 83rd Street and 34-16—34-52 84th Street

Block/lots: 1444/61, 59, 58, 57, 56, 54, 53, 52, 51, 50, 48, 47, 46, 45, 43, 13, 14, 15, 16, 17, 19, 20, 21, 22, 23, 25, 26, 27, 28, 30

34-15 83rd Street [1444/61]	34-16 84th Street [1444/13]
34-19 83rd Street [1444/59]	34-20 84th Street [1444/14]
34-21 83rd Street [1444/58]	34-22 84th Street [1444/15]
34-23 83rd Street [1444/57]	34-24 84th Street [1444/16]
34-25 83rd Street [1444/56]	34-26 84th Street [1444/17]
34-29 83rd Street [1444/54]	34-30 84th Street [1444/19]
34-31 83rd Street [1444/53]	34-32 84th Street [1444/20]
34-33 83rd Street [1444/52]	34-34 84th Street [1444/21]
34-35 83rd Street [1444/51]	34-36 84th Street [1444/22]
34-37 83rd Street [1444/50]	34-38 84th Street [1444/23]
34-41 83rd Street [1444/48]	34-42 84th Street [1444/25]
34-43 83rd Street [1444/47]	34-44 84th Street [1444/26]
34-45 83rd Street [1444/46]	34-46 84th Street [1444/27]
34-47 83rd Street [1444/45]	34-48 84th Street [1444/28]
34-51 83rd Street [1444/43]	34-52 84th Street [1444/30]

Type: Attached & Semi-Detached Houses
(30 buildings)

Stories: 3

Style: Anglo-American Garden Home

Date: 1928-29*

Architect: Pierce L. Kiesewetter

Developer: Plymouth Engineering Corp.

*Nos. 34-29, 34-31, 34-33, 34-35, 34-37, 34-41, 34-43, 34-45, 34-47 83rd Street,
and 34-51 83rd Street — NB 3519-1928

*Nos. 34-15, 34-19, 34-21, 34-23, and 34-25 83rd Street — NB 3520-1928

*Nos. 34-16, 34-20, 34-22, 34-24, and 34-26 84th Street — NB 3517-1928

*Nos. 34-30, 34-32, 34-34, 34-36, 34-38, 34-42, 34-44, 34-46, 34-48, and
34-52 84th Street — NB 3518-1928

Built in 1928-29 to designs by Pierce L. Kiesewetter, the Plymouth Houses are characteristic of many similar groups of attached and semi-detached houses built in Jackson Heights during the second half of the 1920s. This group of thirty houses is arranged on a block plan with back-to-back clusters on 83rd and 84th streets, between 34th and 35th avenues. The fifteen houses on each blockfront are divided into three clusters of five houses each. Garages are located at the rear basements of the houses and are reached by driveways entered and exited at the ends of the blockfronts.

The facade designs of the houses vary in the form and placement of details, using alternating roof profiles, entrance porches in various forms, and projecting bays to create a lively diversity within an overall pattern. The outer five-house clusters of each blockfront have mirror-image configurations ("a-b-c-d-e" at one end and an "e-d-c-b-a" pattern at the other) and the central cluster has a nearly symmetrical configuration ("f-g-h-g-f" with slight variations in the "g" houses). The placement of the individual facade designs is different on each blockfront, but the overall pattern is the same.

Of brick with cast-stone, stucco, and wood trim, the houses are designed in the neo-Tudor style. Elements typical of that style include oriels, battlements, label lintels, half-timbering, clay tile roofs, dormer windows, and gable-end chimneys. Many original multi-pane double-hung wood windows and wood doors remain. The side and rear facades of the houses are similar to the fronts, and are partially visible from the street.

Alterations include the replacement of doors; the resurfacing of portions of some facades with aluminum siding; the installation of through-the-wall air conditioning units; the reconstruction of retaining walls in the front gardens; and the replacement of clay tile roofs.



Plymouth Houses

Block 1444 Lots 13-17, 19-23, 25-28, 30, 43, 45-48, 50-54, 56-59 & 61

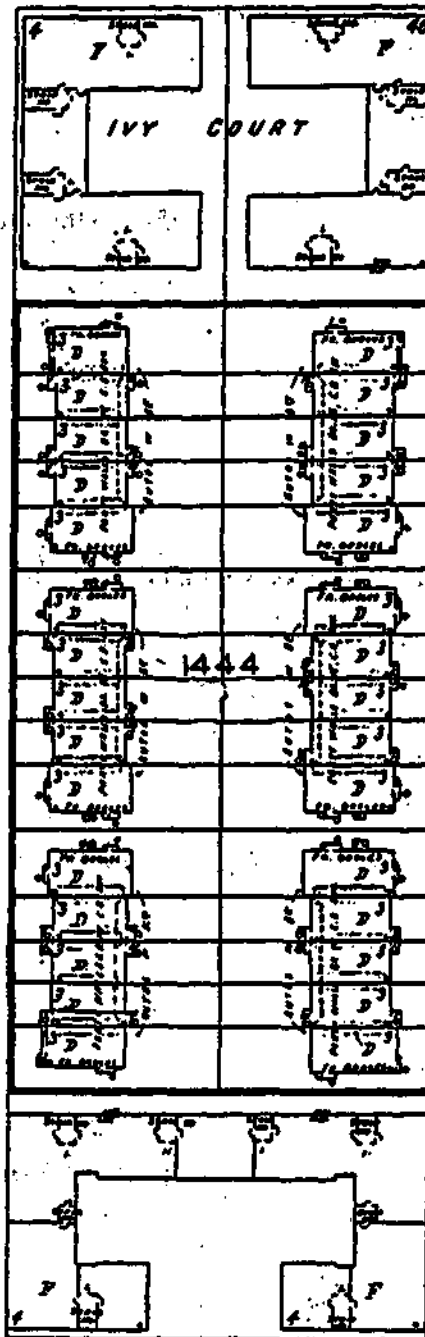

- [1444/61] 34-15 83rd Street
- [1444/59] 34-19 83rd Street
- [1444/58] 34-21 83rd Street
- [1444/57] 34-23 83rd Street
- [1444/56] 34-25 83rd Street

- [1444/54] 34-29 83rd Street
- [1444/53] 34-31 83rd Street
- [1444/52] 34-33 83rd Street
- [1444/51] 34-35 83rd Street
- [1444/50] 34-37 83rd Street

- [1444/48] 34-41 83rd Street
- [1444/47] 34-43 83rd Street
- [1444/46] 34-45 83rd Street
- [1444/45] 34-47 83rd Street
- [1444/43] 34-51 83rd Street

- 34-16 84th Street [1444/13]
- 34-20 84th Street [1444/14]
- 34-22 84th Street [1444/15]
- 34-24 84th Street [1444/16]
- 34-26 84th Street [1444/17]

- 34-30 84th Street [1444/19]
- 34-32 84th Street [1444/20]
- 34-34 84th Street [1444/21]
- 34-36 84th Street [1444/22]
- 34-38 84th Street [1444/23]

- 34-42 84th Street [1444/25]
- 34-44 84th Street [1444/26]
- 34-46 84th Street [1444/27]
- 34-48 84th Street [1444/28]
- 34-52 84th Street [1444/30]

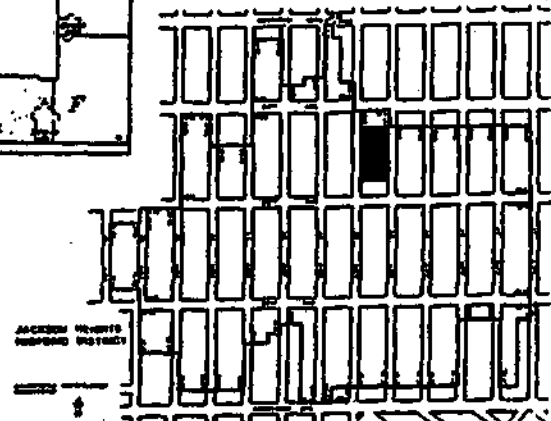

83rd Street — East Side

83rd Street between 35th Avenue and 37th Avenue (East Side)

35-01—35-15 83rd Street

See: 83-02—83-12 35th Avenue

83rd Street between 35th Avenue and 37th Avenue (East Side)

OAK HALL (WEST AND EAST)

35-33 83rd Street and 35-34 84th Street

Block/lots: 1457/56, 18

35-33 83rd Street [1457/56]

35-34 84th Street [1457/18]

Type: Apartment Buildings (2)

Style: Neo-Romanesque

Stories: 6 with basement

Date: 1930-31*

Architect: Cohn Brothers

Developer: Fillmore Gardens Corp.

*No. 35-33 83rd Street — NB 6220-1930

*No. 35-34 84th Street — NB 6070-1930

Built in 1930-31 to designs by the Cohn Brothers, the two back-to-back buildings known as Oak Hall West and Oak Hall East are characteristic of the later phase of apartment house development in the historic district. Each large structure is planned with a broad, recessed entrance court which serves as a lightcourt and breaks up the street front into two sections. There are narrow front gardens.

The identical six-story-and-basement buildings are neo-Romanesque in style, with brick facades enlivened by brick and stone elements, including brickwork patterning, such as bandcourses, diaperwork, corbel tables, and blind arches; brick entrance porticoes with shouldered door openings and arched transoms with stone archivolt; arched windows framed by engaged stone colonnettes; stone and brick-and-stone balconettes; gargoyles and cartouches; and, at the roofline, pediments in the courtyards, square and polygonal towers with arcaded loggias at the corners, and tile coping. At each entry court, brick walls with stone pedestals support stone lions; elaborate ironwork spans the opening between the pedestals.

83rd Street between 35th Avenue and 37th Avenue (East Side)

THE GREENBRIER APARTMENTS

35-49 83rd Street

Block/lot: 1457/48

Type: Apartment Building

Stories: 3

Style: Neo-Georgian (post-World War II)

Date: 1949-50 [NB 3171-1949]

Architect: Boris Dorfman

Developer: Queensboro Corp.

Designed by Boris Dorfman and built in 1949-50, the three-story Greenbrier Apartments is one of several apartment buildings constructed in the post-World War II era of development in Jackson Heights. It is a relatively small building on a mid-block site and has a deeply recessed central court that serves as both entryway and a lightcourt. There is a narrow front garden.



The simple brick facades of the Greenbrier feature a modest application of Georgian-inspired ornamental details, limited to a brick water table, wooden shutters, brick band courses, and a brick parapet with openings containing geometrically-designed iron screens. The original six-over-six double-hung wood sash windows survive, as do the multi-pane wood-and-glass double-doors and transom. Alterations include the removal of the pediment from above the entrance.

Source: Karatzas, 157-158.

83rd Street between 35th Avenue and 37th Avenue (East Side)

35-61 83rd Street

See: 83-01—83-27 37th Avenue

83rd Street between 37th Avenue and Roosevelt Avenue (East Side)

37-01—37-09 83rd Street

See: 83-02—83-14A 37th Avenue

83rd Street between 37th Avenue and Roosevelt Avenue (East Side)

SPANISH GARDENS

37-15—37-57 83rd Street and 37-16—37-58 84th Street

Block/lot: 1471/12

37-19 83rd Street

(a/k/a 37-15—37-23 83rd Street)

37-37 83rd Street

(a/k/a 37-33—37-41 83rd Street)

37-53 83rd Street

(a/k/a 37-49—37-57 83rd Street)

37-20 84th Street

(a/k/a 37-16—37-24 84th Street)

37-38 84th Street

(a/k/a 37-34—37-42 84th Street)

37-54 84th Street

(a/k/a 37-50—37-58 84th Street)

Type: Garden Apartments (6 buildings)

Stories: 4 and 5

Style: Neo-Spanish Renaissance

Date: 1924-26*

Architect: Andrew J. Thomas

Developer: J. Conforti Construction Co.

*No. 37-15—37-23 83rd Street — NB 19208-1924

*No. 37-33—37-41 83rd Street — NB 19205-1924

*No. 37-49—37-57 83rd Street — NB 19210-1924

*No. 37-16—37-24 84th Street — NB 19209-1924

*No. 37-34—37-42 84th Street — NB 19206-1924

*No. 37-50—37-58 84th Street — NB 19207-1924

The Spanish Gardens, built in 1924-26 and designed by Andrew J. Thomas, is one of the characteristic garden apartment projects in Jackson Heights. Occupying most of the block, the complex of six freestanding H-shaped buildings is planned with three buildings along each blockfront joined by a common landscaped garden at the interior of the block. The passageways between the buildings are spanned at the street front by brick walls and entrance gates. Each building also has a front garden.

→

Each of the brick buildings has a broad, recessed five-story section and projecting end sections of four stories; this plan creates an entrance court at the front. The side facades also have shallow and wide lightcourts. Each building has a central entryway in a projecting stone porch flanked at each side by secondary entrances in arched stone enframements.

In 1925, the *Jackson Heights News* sponsored a contest to select a name for the complex. The name "Spanish Gardens" was chosen because it appropriately reflected the Spanish flavor of the building's architectural features. Among the Spanish Renaissance-inspired details are the entrance porches with engaged pilasters supporting red tile roofs, surmounted by terra-cotta *escudos* (shields) flanked by griffons; the corbeled balconette flanked by Moorish style pilasters in the central stairhall bay; and the tiled roof parapets. The sides and rear facades of the buildings are similar to the fronts. Many of the original six-over-six and eight-over-eight double-hung wood sash windows survive. Alterations include replacement doors.

Source: *Jackson Heights News*, May 1, 1925, p. 4.



Spanish Gardens

Block 1471 Lot 12

37-19 83rd Street

37-20 84th Street

37-37 83rd Street

37-38 84th Street

37-53 83rd Street

37-54 84th Street

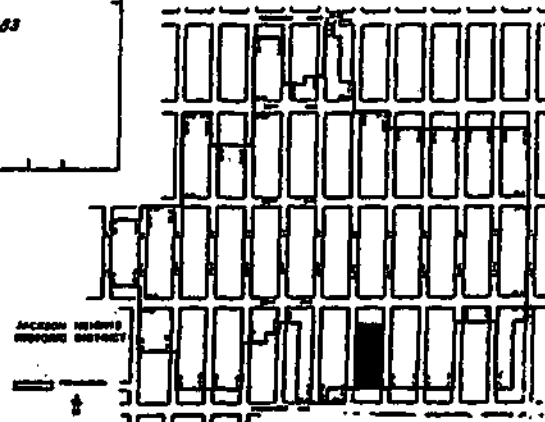
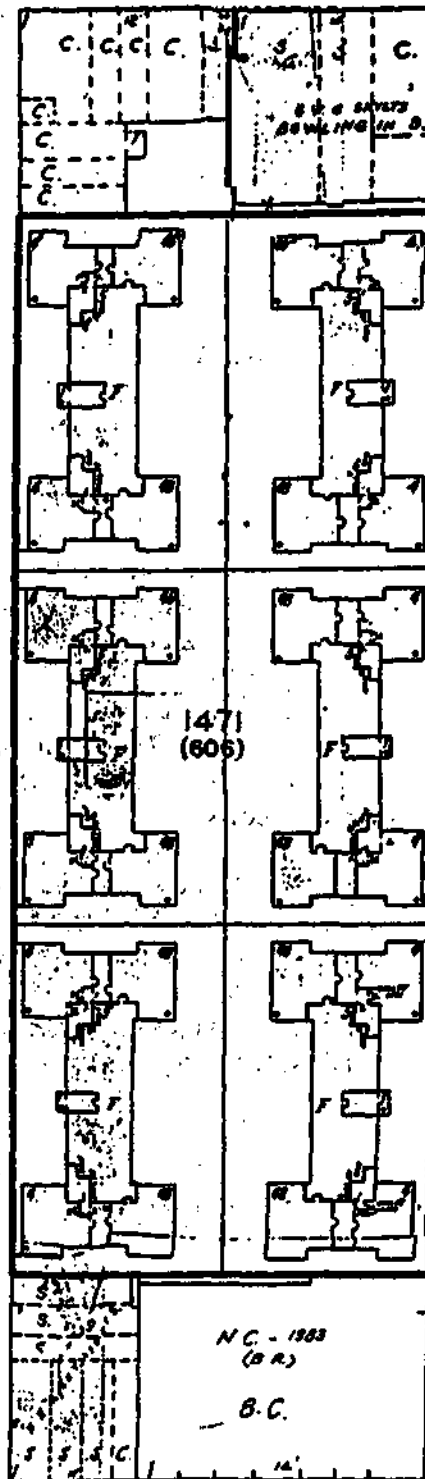

83rd Street - East Side

83RD STREET — West Side

83rd Street between Northern Boulevard and 34th Avenue (West Side)

33-54 83rd Street

See: 33-53 82nd Street

83rd Street between 34th Avenue and 35th Avenue (West Side)

34-02—34-06 83rd Street

See: 82-02—82-20 34th Avenue

83rd Street between 34th Avenue and 35th Avenue (West Side)

COLONIAL ARMS

34-20 83rd Street

Block/lots: 1443/1000-1052

Type: Apartment Building
Stories: 6 with basement
Style: Neo-Georgian

Date: 1935 [NB 1303-1935]
Architect: Cohn Brothers
Developer: Three Star Building Corp.

Built in 1935 to designs by the Cohn Brothers, the six-story-and-basement Colonial Arms is among the later apartment buildings erected in the historic district. Typical of that phase of development, it is a large building on a mid-block site and planned with a recessed lightcourt which breaks up the street front into two sections and serves as an entrance court.

Neo-Georgian in style, the building is faced in red brick with white trim and is similar in its design to the two buildings on the 35th Avenue blockfront between 82nd and 83rd streets: **Georgian Gardens at 34-57 82nd Street**, designed by the Cohn firm in 1935-36, and **Senate Gardens at 82-15 35th Avenue**, designed by Seelig & Finkelstein in 1937. Ornamental elements include the door surround with a broken pediment; brickwork imitating quoins; flat pilasters with stone bases and stylized stone capitals; brick bandcourses suggestive of entablatures; windows set into relieving arches with stone keystones; splayed stone lintels; and, at the roofline, brick pediments pierced by oculi and parapet balustrades.

Alterations include replacement entrance doors, the removal of balconettes from bays at the second story (the brackets remain), and the loss of decorative urns at the roofline.

83rd Street between 34th Avenue and 35th Avenue (West Side)

34-24 83rd Street

See: 34-25 82nd Street

83rd Street between 34th Avenue and 35th Avenue (West Side)

34-32—34-50 83rd Street

Block/lots: 1443/21, 22, 23, 24, 25, 27, 28, 29, 30, 31

34-32 83rd Street [1443/21]

34-34 83rd Street [1443/22]

34-36 83rd Street [1443/23]

34-38 83rd Street [1443/24]

34-40 83rd Street [1443/25]

34-42 83rd Street [1443/27]

34-44 83rd Street [1443/28]

34-46 83rd Street [1443/29]

34-48 83rd Street [1443/30]

34-50 83rd Street [1443/31]

Type: Attached & Semi-Detached Houses
(10 buildings)

Stories: 3

Style: Anglo-American Garden Home

Date: 1928-29*

Architect: James D. Junge

Developer: Carrizzo & Brunetti

*Nos. 34-32, 34-34, 34-36, 34-38, and 34-40 83rd Street — NB 6825-1928

*Nos. 34-42, 34-44, 34-46, 34-48, and 34-50 83rd Street — NB 6798-1928

Built in 1928-29 to designs by James D. Junge, this group of ten houses is characteristic of many similar groups of attached and semi-detached houses built in Jackson Heights during the second half of the 1920s. The houses are arranged in two clusters of five attached houses each, with front gardens, attached garages, and a common driveway in the rear.

Each five-house cluster is designed in an "a-b-c-b-a" pattern, a symmetrical configuration which produces the effect of a larger single entity. The placement of the entrances in a mirror-image formation and the alternating roof profiles help to reinforce the symmetry of each group, and the overall consistency of the patterning gives the blockfront a cohesive design.

The design of the houses is drawn largely from the neo-Georgian style. Elements typical of that style are the red brick facing laid in Flemish bond; front porches with pitched roofs ("a" houses) and pent hoods ("b" and "c" houses); window and door openings with segmental heads; paneled wood doors; multi-pane double-hung windows; wooden shutters; iron balconettes; and pitched roofs with gables, shed dormers, and chimneys. Spanish tiles are used on the roofs and hoods. The side facades of the end houses, each with a chimney and bay window, are visible from the street.

The driveway leading to the interior of the block is entered at the ends of the blockfront. The ten garages are arranged in two groups of five each, one garage per house. The design of the brick garages, with pedimented tile roofs and dormers, is similar to that of the houses.

Alterations include rebuilt retaining walls in front and the removal of several window hoods. Some original windows survive.



83rd Street between 35th Avenue and 37th Avenue (West Side)

SAINT JOAN OF ARC R.C. CHURCH COMPLEX

See: 35th Avenue between 82nd and 83rd Streets (South Side)

34-32—34-50 83rd Street

Block 1443 Lots 21-25 & 27-31

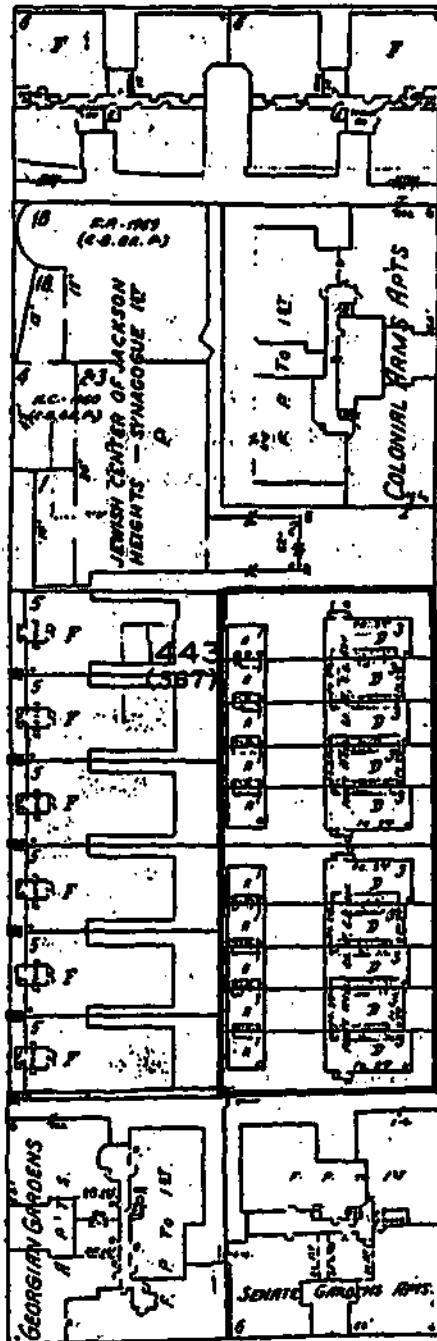

- 34-32 83rd Street [1443/21]
- 34-34 83rd Street [1443/22]
- 34-36 83rd Street [1443/23]
- 34-38 83rd Street [1443/24]
- 34-40 83rd Street [1443/25]
- 34-42 83rd Street [1443/27]
- 34-44 83rd Street [1443/28]
- 34-46 83rd Street [1443/29]
- 34-48 83rd Street [1443/30]
- 34-50 83rd Street [1443/31]

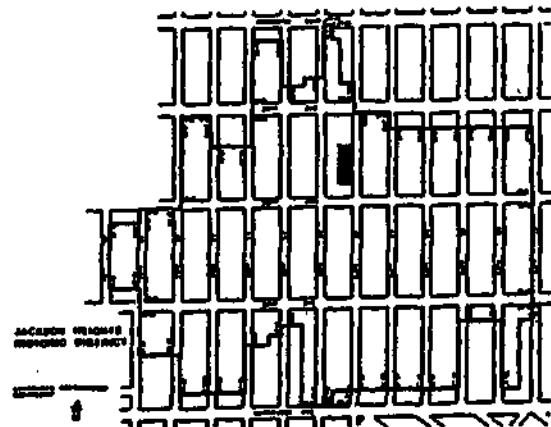

83rd Street between 35th Avenue and 37th Avenue (West Side)

THE ALDEN APARTMENTS

35-36—35-40 83rd Street
Block/lot: 1456/22

Type: Apartment Building
Stories: 6 with basement
Style: Neo-Georgian

Date: 1937 [NB 442-1937]
Architect: Cohn Brothers
Developer: Durkam Operating Co.

Built in 1937 to designs by the Cohn Brothers, the six-story-and-basement building known as the Alden Apartments is among the later apartment buildings erected in the historic district. Typical of that phase of development, it is a large building on a mid-block site and planned with two deeply recessed entrance courts which also serve as lightcourts and break up the street front into two sections. There is a front garden behind a short retaining wall.

Neo-Georgian in style, the building has brick facades with cast-stone trim. Elements typical of that style include brickwork laid up to imitate quoins and brick band courses; monumental stone orders at the upper stories of each section, comprised of fluted pilasters, stylized Corinthian capitals, and entablatures; brick gables with oculi and multiple chimney pots and modified gabled dormers; a semi-circular entrance porch with an entablature, sheltering an elaborate entry with wood pilasters and panels, sidelights, and a leaded fanlight; and, above the entrance, a paired window in a stone enframingent with a broken pediment. The entry court is framed by brick pedestals topped by urns. Balconettes have been removed from the dormer windows (the brackets remain) and the dormers have been resurfaced.

83rd Street between 35th Avenue and 37th Avenue (West Side)

35-54—35-56 83rd Street
See: 35-51—35-55 82nd Street

83rd Street between 35th Avenue and 37th Avenue (West Side)

35-64 83rd Street
See: 82-01—82-21 37th Avenue

83rd Street between 37th Avenue and Roosevelt Avenue (West Side)

37-02—37-10 83rd Street
See: 82-12—82-20 37th Avenue

83rd Street between 37th Avenue and Roosevelt Avenue (West Side)

37-16—37-20 83rd Street
Block/lot: 1470/12

Type: Apartment Building
Stories: 6
Style: Neo-Romanesque

Date: 1927-28 [NB 9560-1927]
Architect: Franklin, Bates & Heindsmann
Developer: Heights Construction Corp.

Built in 1927-28 to designs by Frankin, Bates & Heindsmann, this six-story-and-basement building is a large U-shaped structure with a deep entrance court which breaks up the street front into two sections. Each section has its own entrance in the courtyard.

Neo-Romanesque in style, the building is faced with textured brick and features decorative brickwork motifs such as banding at the base, diaperwork, and notched corbel tables at the roofline. The two courtyard entrances are identical brick porticoes with flanking pedestals bearing urns. Double-leaf multi-pane wood doors with transoms are extant. Fixed canopies have been added to the entrances.

83rd Street between 37th Avenue and Roosevelt Avenue (West Side)

THE MONTEREY APARTMENTS

37-30 83rd Street

Block/lot: 1470/24

Type: Apartment Building

Stories: 6 with basement

Style: Moderne (post-World War II)

Date: 1953-54 [NB 4324-1953]

Architect: Seelig & Finkelstein

Developer: Ritalfo Building Corp.

Designed by Seelig & Finkelstein and built in 1953-54, the six-story-and-basement Monterey Apartments is one of several apartment buildings constructed in the post-World War II era of development in Jackson Heights. Continuing the trend of the pre-War years, it is a large building planned with a deeply recessed entrance court at the center of the street front which breaks up the building into two sections; each section has a broad recess at the front. A vehicular door at the north end of the building leads to a basement garage. There are walled planting beds along the base of the building.

A late interpretation of the Moderne style, the brick building has minimal ornamentation, limited to subtle brick band courses and brick corner quoins. The plate-glass entrance, located slightly below grade, is set into a granite surround. Above is a metal-trimmed marquee topped by an iron railing.

83rd Street between 37th Avenue and Roosevelt Avenue (West Side)

37-46—37-60 83rd Street

Block/lots: 1470/29, 30, 31, 32, 33, 34, 35, 36

37-46 83rd Street [1470/29]

37-48 83rd Street [1470/30]

37-50 83rd Street [1470/31]

37-52 83rd Street [1470/32]

37-54 83rd Street [1470/33]

37-56 83rd Street [1470/34]

37-58 83rd Street [1470/35]

37-60 83rd Street [1470/36]

Type: Rowhouses (8 of 10)

Stories: 2 with basement

Style: Neo-classical

Date: 1911 [NB 1017-1911]

Architect: Charles Peck

Developer: Charles E. Currier Co. Inc.

Built in 1911 to designs by Charles Peck, this surviving group of eight rowhouses (originally ten) on the west side of 83rd Street is the earliest development project in the Jackson Heights Historic District. The row was constructed in conjunction with an identical row of houses by Peck located back-to-back at 37-47—37-59 82nd Street; those were altered and converted for commercial use in the subsequent decades.

The two-story-and-basement houses have front stoops and are set back behind small front yards. The brick facades feature neo-classical ornamental details in stone, wood, and metal. The houses alternate in pairs which have either projecting three-sided brick bays at the first story or three-sided oriels embellished with engaged colonnettes at the second story. Stone lintels and modillioned cornices further enhance the design of the row. Historic double-leaf wood-and-glass doors are extant at Nos. 37-46, 37-48, 37-50, 37-52, and 37-54.



83rd Street between 37th Avenue and Roosevelt Avenue (West Side)

37-62—37-66 83rd Street

See: 82-01—82-19 Roosevelt Avenue

37-46—37-60 83rd Street

Block 1470 Lots 29-36

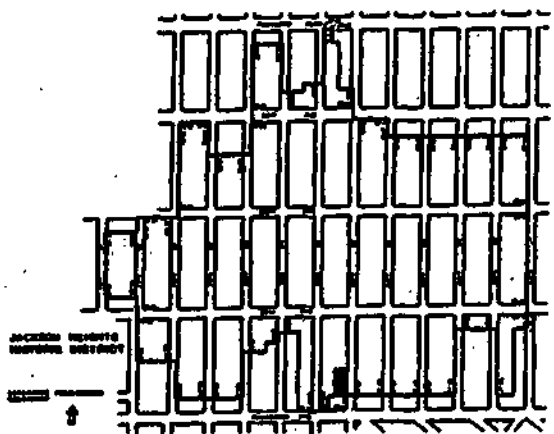
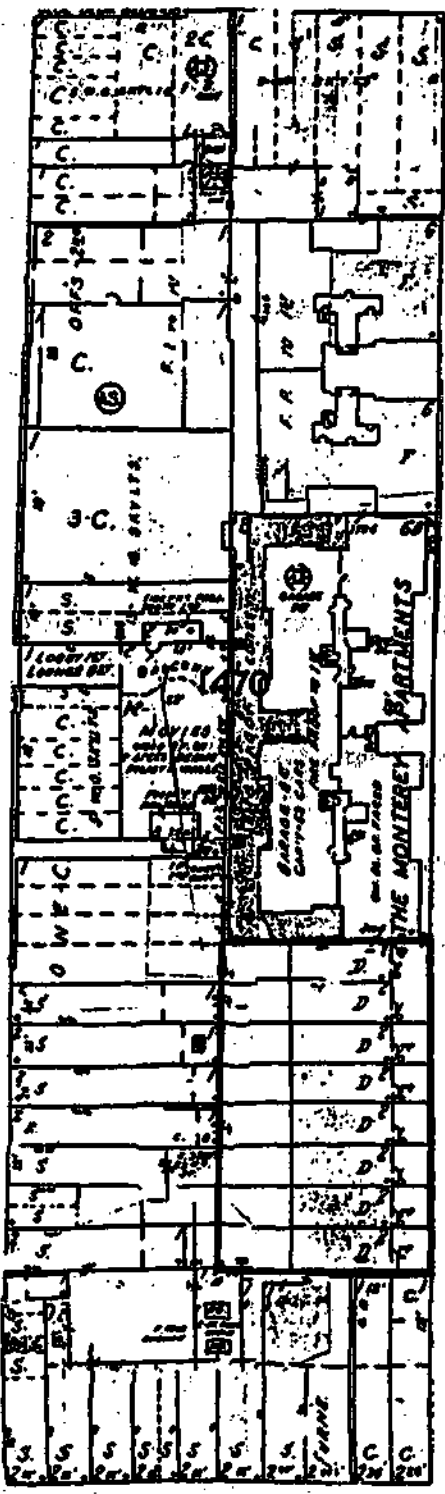

- 37-46 83rd Street [1470/29]
- 37-48 83rd Street [1470/30]
- 37-50 83rd Street [1470/31]
- 37-52 83rd Street [1470/32]
- 37-54 83rd Street [1470/33]
- 37-56 83rd Street [1470/34]
- 37-58 83rd Street [1470/35]
- 37-60 83rd Street [1470/36]

84TH STREET — East Side

84th Street between 34th Avenue and 35th Avenue (East Side)

34-11—34-51 84th Street and 34-14—34-52 85th Street

Block/lots: 1445/63, 62, 61, 60, 58, 57, 56, 55, 53, 52, 51, 50, 48, 47, 46, 44, 12, 14, 15, 16, 18, 19, 20, 21, 23, 24, 25, 26, 28, 29, 30, 31

34-11 84th Street [1445/63]	34-14 85th Street [1445/12]
34-15 84th Street [1445/62]	34-16 85th Street [1445/14]
34-17 84th Street [1445/61]	34-18 85th Street [1445/15]
34-21 84th Street [1445/60]	34-20 85th Street [1445/16]
34-23 84th Street [1445/58]	34-24 85th Street [1445/18]
34-25 84th Street [1445/57]	34-26 85th Street [1445/19]
34-27 84th Street [1445/56]	34-28 85th Street [1445/20]
34-31 84th Street [1445/55]	34-30 85th Street [1445/21]
34-33 84th Street [1445/53]	34-34 85th Street [1445/23]
34-37 84th Street [1445/52]	34-36 85th Street [1445/24]
34-39 84th Street [1445/51]	34-38 85th Street [1445/25]
34-41 84th Street [1445/50]	34-40 85th Street [1445/26]
34-45 84th Street [1445/48]	34-44 85th Street [1445/28]
34-47 84th Street [1445/47]	34-46 85th Street [1445/29]
34-49 84th Street [1445/46]	34-50 85th Street [1445/30]
34-51 84th Street [1445/44]	34-52 85th Street [1445/31]

Type: Attached & Semi-Detached Houses
(32 buildings)

Style: Anglo-American Garden Home

Date: 1927*

Architect: Robert Tappan

Developer: Queensboro Corp.

*Nos. 34-11, 34-15, 34-17, and 34-21 84th Street — NB 2937-1927

*Nos. 34-23, 34-25, 34-27, and 34-31 84th Street — NB 2938-1927

*Nos. 34-33, 34-37, 34-39, and 34-41 84th Street — NB 2939-1927

*Nos. 34-45, 34-47, 34-49, and 34-51 84th Street — NB 2932-1927

*Nos. 34-14, 34-16, 34-18, and 34-20 85th Street — NB 2933-1927

*Nos. 34-24, 34-26, 34-28, and 34-30 85th Street — NB 2936-1927

*Nos. 34-34, 34-36, 34-38, and 34-40 85th Street — NB 2935-1927

*Nos. 34-44, 34-46, 34-50, and 34-52 85th Street — NB 2934-1927

Built in 1927 to designs by Robert Tappan, this group of thirty-two houses is characteristic of many similar groups of attached and semi-detached houses built in Jackson Heights during the second half of the 1920s. Located on 84th and 85th streets, between 34th and 35th avenues, the houses are arranged on a block plan with eight back-to-back clusters of four houses each, four clusters on each street. Paired garages (one per house) are located at the rear and reached by a common driveway. All the houses have front gardens.

The four houses of each group are designed in a mirror-image "a-b-b-a" pattern which produces the effect of a larger single entity. The four clusters on each street are, in turn, also arranged in a mirror-image pattern ("A-B-B-A"), giving the whole blockfront a cohesive design. The "A" clusters on both blockfronts are the same, and the "B" clusters are similar but not identical. In the "A" cluster, the "a" and "b" houses share between them a projecting gabled section containing the entrances to the two

separate houses. In the "B" cluster on 84th Street, the "a" houses have projecting gabled ends with pedimented porches, while the two "b" houses share between them a two-story flat-roofed pavilion containing the entrances. In the the "B" cluster on 85th Street, the "a" houses have projecting brick entrance porches and the "b" houses share a projecting gabled section with two entrances.

Faced in red brick with white trim, the houses are neo-Georgian in style. This style is characterized by such details as the peaked and gabled slate roofs with single and paired dormers; the round-arched front doors with fanlights in some house models, and the white wood, classically-inspired porches or overhanging pediments in others; the brick quoining; and the prominent chimneys. The side and rear facades of the houses are similar to the fronts, and are partially visible from the street. The side facades of the end houses have porches. The houses are remarkably intact, and retain almost all the original six-over-six and eight-over-eight wood sash windows and many of the original wood paneled and wood-and-glass doors. Storm windows and doors have been added on many houses.

The paired garages at the rear have peaked slate roofs and continue the style of the houses.



84th Street between 35th Avenue and 37th Avenue (East Side)

35-01 84th Street

See: 84-02—84-12 35th Avenue

84th Street between 35th Avenue and 37th Avenue (East Side)

BELVEDERE GARDENS (WEST and EAST)

35-15 84th Street and 35-16 85th Street

Block/lot: 1458/12

Type: Apartment Buildings (2)

Stories: 6

Style: Neo-Georgian

Date: 1939-40 [NB 7739-1939]

Architect: Seelig & Finkelstein

Developer: Rosene Holding Corp.

Built in 1939-40 to designs by Seelig & Finkelstein, the six-story Belvedere Gardens West (84th Street) and East (85th Street) are among the later apartment buildings erected in the historic district. Characteristic of that phase of development, the two identical six-story apartment houses are situated back-to-back on a mid-block site that extends through the block. Each building is planned with a recessed entrance court that also serves as a lightcourt and breaks up the street front into two sections. The buildings share a common rear garden with each other and with the larger **Belvedere Apartments** to the north on 35th Avenue.

Faced in brick, the buildings are neo-Georgian in style. Elements typical of the style include patterned brickwork suggestive of quoins, modillioned band courses, and Palladian window heads (top story); and at the roofline, notched gables and parapets with balustrades. Each building has an entrance portico with applied pilasters, an entablature, and a door surround with a scrolled pediment and a leaded transom.

34-11—34-51 84th Street and 34-14—34-52 85th Street

Block 1445 Lots 12, 14-16, 18-21, 23-26, 28-31, 44, 46-48, 50-53, 55-58 & 60-63

34-11 84th Street [1445/63]
 34-15 84th Street [1445/62]
 34-17 84th Street [1445/61]
 34-21 84th Street [1445/60]

34-23 84th Street [1445/58]
 34-25 84th Street [1445/57]
 34-27 84th Street [1445/56]
 34-31 84th Street [1445/55]

34-33 84th Street [1445/53]
 34-37 84th Street [1445/52]
 34-39 84th Street [1445/51]
 34-41 84th Street [1445/50]

34-45 84th Street [1445/48]
 34-47 84th Street [1445/47]
 34-49 84th Street [1445/46]
 34-51 84th Street [1445/44]

34-14 85th Street [1445/12]
 34-16 85th Street [1445/14]
 34-18 85th Street [1445/15]
 34-20 85th Street [1445/16]

34-24 85th Street [1445/18]
 34-26 85th Street [1445/19]
 34-28 85th Street [1445/20]
 34-30 85th Street [1445/21]

34-34 85th Street [1445/23]
 34-36 85th Street [1445/24]
 34-38 85th Street [1445/25]
 34-40 85th Street [1445/26]

34-44 85th Street [1445/28]
 34-46 85th Street [1445/29]
 34-50 85th Street [1445/30]
 34-52 85th Street [1445/31]

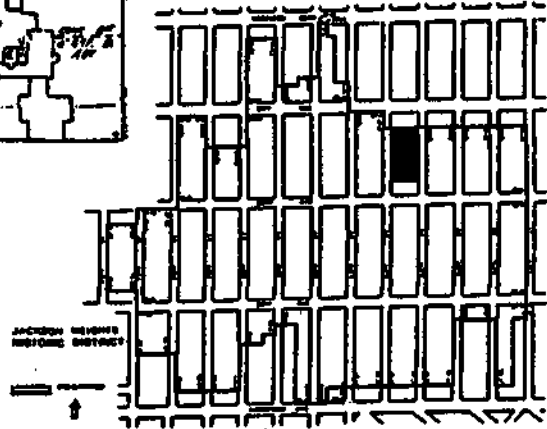
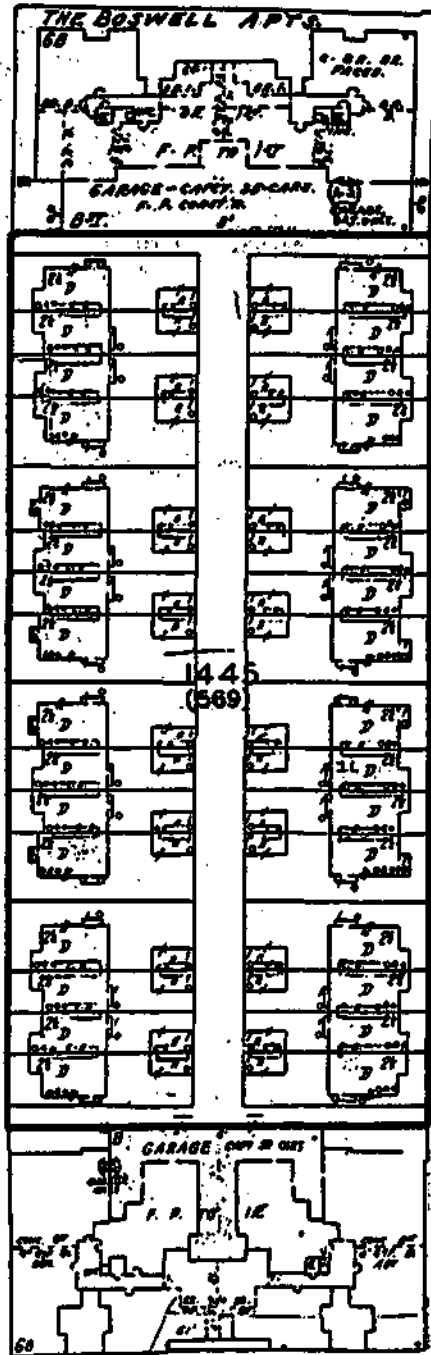

84th Street between 35th Avenue and 37th Avenue (East Side)

THE LITCHFIELD APARTMENTS

35-43 84th Street

Block/lot: 1458/46

Type: Apartment Building

Stories: 6

Style: Neo-Georgian

Date: 1939-40 [NB 7937-1939]

Architect: Joshua Tabatchnik

Developer: Henry Friedland

Built in 1939-40 to designs by Joshua Tabatchnik, the six-story Litchfield Apartments is among the later apartment buildings erected in the historic district. Characteristic of that phase of development, it is a large building planned with three recessed lightcourts which break up the long street front into four sections. The wider central lightcourt also serves as the entrance court.

Faced in brick, the building is neo-Georgian in style. Elements typical of that style include patterned brickwork suggestive of quoins, dentils, and Palladian window heads; the basket-arched entranceway with pilasters, sidelights, and a leaded transom; and notched gables at the roofline.

84th Street between 35th Avenue and 37th Avenue (East Side)

35-59—35-67 84th Street

See: 84-01—84-09 37th Avenue

84th Street between 37th Avenue and Roosevelt Avenue (East Side)

37-01 84th Street

See: 84-02—84-30 37th Avenue

84th Street between 37th Avenue and Roosevelt Avenue (East Side)

LINDEN COURT

37-11—37-59 84th Street and 37-12—37-60 85th Street

Block/lots: 1472/68, 65, 60, 51, 47, 11, 15, 20, 28, 34,

37-11 and 37-17 84th Street [1472/68]

37-21 and 37-27 84th Street [1472/65]

37-33 and 37-39 84th Street [1472/60]

37-45 and 37-51 84th Street [1472/51]

37-55 and 37-59 84th Street [1472/47]

37-12 and 37-18 85th Street [1472/11]

37-22 and 37-28 85th Street [1472/15]

37-34 and 37-40 85th Street [1472/20]

37-46 and 37-52 85th Street [1472/28]

37-56 and 37-60 85th Street [1472/34]

Type: Garden Apartments (10 buildings)

Stories: 4 with basement

Style: Neo-Romanesque

Date: 1919-21*

Architect: Andrew J. Thomas

Developer: Jackson Heights Apt. Corp.

*No. 37-11--37-17 84th Street — NB 2766-1919

*No. 37-21--37-27 84th Street — NB 2760-1919

*No. 37-33--37-39 84th Street — NB 2764-1919

*No. 37-45--37-51 84th Street — NB 2759-1919

*No. 37-55--37-59 84th Street — NB 2765-1919

*No. 37-12--37-18 85th Street — NB 2767-1919

*No. 37-22--37-28 85th Street — NB 2762-1919

*No. 37-34--37-40 85th Street — NB 2763-1919

*No. 37-46--37-52 85th Street — NB 2761-1919

*No. 37-56--37-60 85th Street — NB 2603-1919

Linden Court, designed by Andrew J. Thomas and built in 1919-21, was the earliest of the large, through-the-block, garden apartment complexes in Jackson Heights. Occupying most of the block, the complex of ten four-story-and-basement buildings is planned as five structures (each composed of two units) along each blockfront. The buildings are organized back-to-back across a common landscaped garden at the interior of the block. This scheme served as the model for subsequent block-plan garden apartments in Jackson Heights. Linden Court was the first complex in Jackson Heights to have parking facilities; the passageways between the buildings serve as driveways which lead to one-story garages located in the lightcourt area at the rear of each building. It was also the first to offer a plan of cooperative ownership.

The five buildings on each blockfront are nearly identical, forming a symmetrical "A-B-C-B-A" pattern in which the "C" building is the widest and the "B" and "A" buildings are progressively narrower. Each building has a flush street front and an ample lightcourt at the rear. The facade of each building has two arched entrances, one leading to each unit. Corner bays have enlarged window openings which create sun porches; those at the top story are treated as enclosed loggias which have pilasters and engaged colonnettes supporting red tile roofs.

The style of Linden Court is derived largely from Spanish Romanesque and Renaissance sources. In addition to the sun porches and loggias, elements of this Mediterranean-inspired style include patterned brickwork; the terra-cotta lintels and keystones with *escudos* (shields); the round-arched entranceways containing heavy double wooden doors and tympani with iron grilles; red roof tiles at the parapets; and wrought-iron balconettes.

The side facades and portions of the rear facades are visible from the street through the driveways between the buildings. All of the original wood entrance doors remain intact. Some of the multi-pane double-hung wood sash windows survive; many of the original multi-pane casement windows in the sun porches remain intact.



Linden Court

Block 1472 Lots 11, 15, 20, 28, 34, 47, 51, 60, 65 & 68

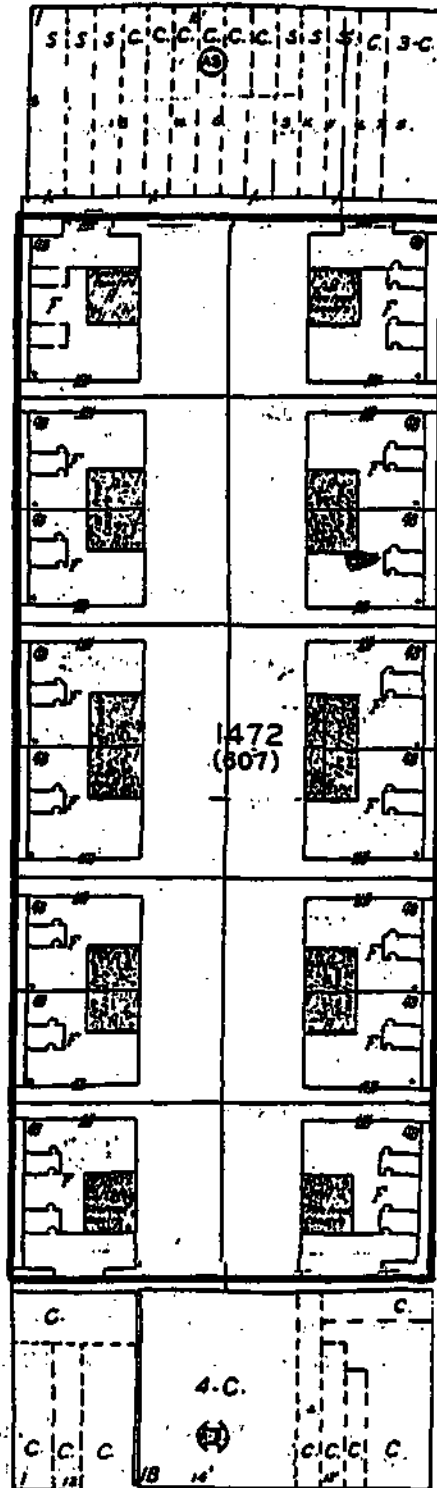

37-11 84th Street
[1472/68]
37-17 84th Street

37-12 85th Street
[1472/11]
37-18 85th Street

37-21 84th Street
[1472/65]
37-27 84th Street

37-22 85th Street
[1472/15]
37-28 85th Street

37-33 84th Street
[1472/60]
37-39 84th Street

37-34 85th Street
[1472/20]
37-40 85th Street

37-45 84th Street
[1472/51]
37-51 84th Street

37-46 85th Street
[1472/28]
37-52 85th Street

37-55 84th Street
[1472/47]
37-59 84th Street

37-56 85th Street
[1472/34]
37-60 85th Street

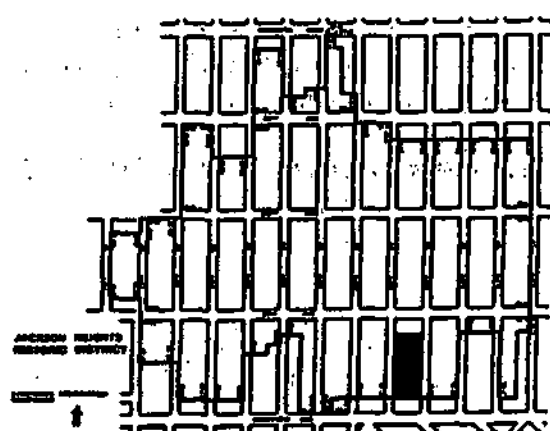

84TH STREET — West Side

84th Street between 34th Avenue and 35th Avenue (West Side)

34-02—34-10 84th Street

See: 34-01—34-09 83rd Street

84th Street between 34th Avenue and 35th Avenue (West Side)

34-16—34-52 84th Street

See: 34-15—34-51 83rd Street

84th Street between 35th Avenue and 37th Avenue (West Side)

35-02—35-16 84th Street

See: 83-02—83-12 35th Avenue

84th Street between 35th Avenue and 37th Avenue (West Side)

35-34 84th Street

See: 83-01—83-27 37th Avenue

84th Street between 35th Avenue and 37th Avenue (West Side)

35-46—35-54 84th Street

Block/lots: 1457/29, 30, 31, 32, 33

35-46 84th Street [1457/29]

35-48 84th Street [1457/30]

35-50 84th Street [1457/31]

35-52 84th Street [1457/32]

35-54 84th Street [1457/33]

Type: Attached Houses (5 buildings)

Stories: 2 and one-half

Style: Post-World War II vernacular

Date: 1951*

Architect: T. Atcuri

Developer: Ideal Homes

*No. 35-46 84th Street — NB 3761-1951

*No. 35-48 84th Street — NB 3762-1951

*No. 35-50 84th Street — NB 3763-1951

*No. 35-52 84th Street — NB 3764-1951

*No. 35-54 84th Street — NB 3765-1951

Built in 1951 to designs by T. Atcuri, these attached houses comprise one of the few rows of houses built during the post-World War II-era in Jackson Heights. Each of the two-and-one-half-story brick houses has a ground-level garage entered from the street and a raised entrance reached by a tall stoop with a landing. The stoops have iron railings, and there are small front yards enclosed by iron fences.

The brick-faced houses have permastone bands beneath the second-story windows, hoods covered with red tiles over the entryways, brick banding, and pent-roofed parapets with red tiles. Several of the original steel casement windows remain.

84th Street between 35th Avenue and 37th Avenue (West Side)

35-64 84th Street

See: 83-01—83-27 37th Avenue

84th Street between 37th Avenue and Roosevelt Avenue (West Side)

37-10 84th Street

See: 83-14 37th Avenue

84th Street between 37th Avenue and Roosevelt Avenue (West Side)

37-16—37-58 84th Street

See: 37-15—37-57 83rd Street

85TH STREET — East Side

85th Street between 34th Avenue and 35th Avenue (East Side)

CARLTON HOUSE

34-15—34-41 85th Street
Block/lot: 1446/45

Type: Apartment Building
Stories: 6 with basement
Style: Moderne (Post-World War II)

Date: 1946-47 [NB 1510-1946]
Architect: Philip Birnbaum
Developer: W. & H. Walker

Designed by Philip Birnbaum and built in 1946-47, the six-story-and-basement Carlton House is one of several apartment buildings constructed in the post-World War II era of development in Jackson Heights. Continuing the trend of the pre-War years, it is a large building planned with lightcourts which break up the mass into five sections. This configuration suggests a cohesive group of buildings along the blockfront, reminiscent of the Jackson Heights garden apartments of the 1920s. There is a parking garage under the building (a vehicular entrance is located at each end) and a small front garden.

A late interpretation of the Moderne style, the brick building is distinguished by the horizontal emphasis of its massing, particularly evident in the deep center and corner terraces trimmed with brick courses and white coping. The building is entered at the central section through a polished metal and marble frontispiece with a geometric metal marquee. There are also a few classicizing ornamental elements, including applied stone acanthus leaves and fretwork panels. Some of the terraces have been enclosed.

85th Street between 35th Avenue and 37th Avenue (East Side)

ROOSEVELT TERRACE

35-01—35-51 85th Street (a/k/a 85-02 35th Avenue and 35-02 86th Street) and 35-20—35-50 85th Street
Blocks/lots: 1459/1 and 1458/20

35-01-35-11 85th Street and 35-31 85th Street
and 35-51 85th Street [1459/1]

35-20—35-50 85th Street [1458/20]

Type: Apartment Buildings (4)

Date: 1952-54*

Stories: 9

Architect: Philip Birnbaum

Style: International Style

Developer: Riverbank Realty Corp.

*Nos. 35-01—35-51 85th Street — NB 6956-1952

*No. 35-20—35-50 85th Street — NB 6957-1952

Roosevelt Terrace, completed in 1954, occupies almost the full block between 85th and 86th Streets from 37th to 35th Avenues and includes an additional site on the west side of 85th Street (No. 32-20--32-50). It was designed by Philip Birnbaum, a prolific New York City architect, and is an example of the many large apartment complexes built in Queens during the 1950s. This project was built on the site of a playground. Typically, post-World War II development in Jackson Heights replaced open areas formerly occupied by community amenities such as the golf course and tennis courts.

The complex consists of three identical nine-story "E"-shaped buildings sited diagonally across the block, from 35th Avenue to just short of the block end at 37th Avenue, with the long sides of each "E" facing south. Two large above-ground parking lots with entrances from 86th Street are located between the buildings, and below these are two underground parking garages with entrances on 85th Street. The periphery of the parking lots and open areas are landscaped, as is the park area located in the southernmost triangle of the site. A fourth "E"-shaped building, constructed as part of the same project, is located on the west side of 85th Street. It has a playground and an underground garage at the north end of the site.

The four brick-faced buildings have continuous terraces with pale green wrought-iron railings, set between flat-walled end pavilions. The terraces provide an unifying design motif for the complex. Some of the terraces have been enclosed. The entrances to the buildings contain glass doors in metal frames sheltered by curved marquees with metal trim. Many of the original steel-framed casement windows survive.

Source: Karatzas, 161.



Roosevelt Terrace

Block 1458 Lot 20 &
Block 1459 Lot 1

35-20 85th Street

1458

[1458/20]

35-50 85th Street

85th Street

35-01 85th Street

35-11 85th Street

[1459/1]

35-31 85th Street

35-51 85th Street

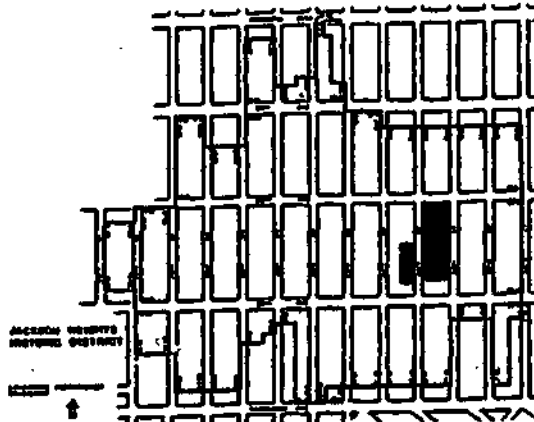
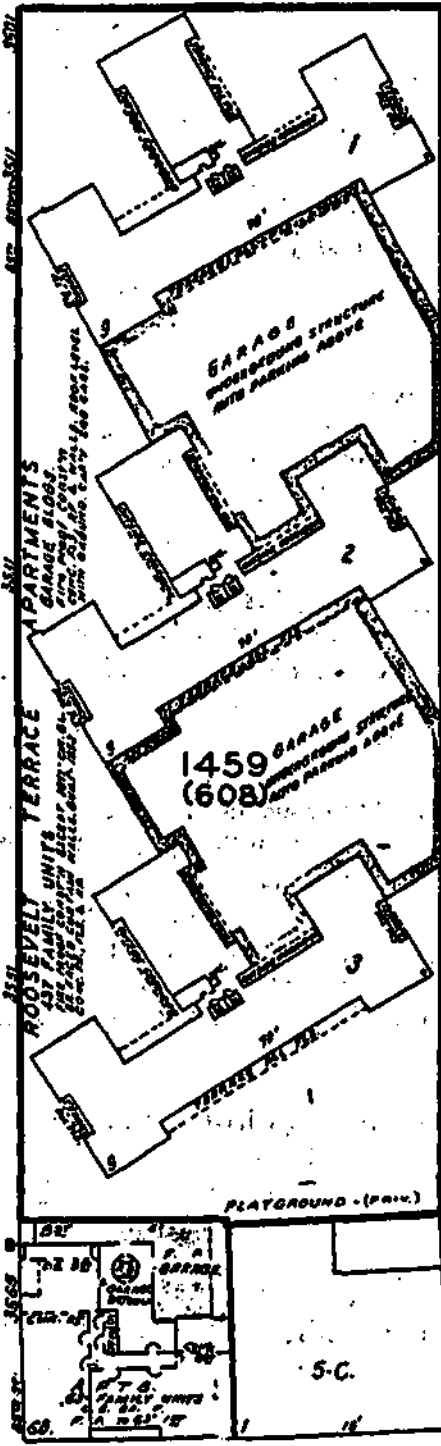
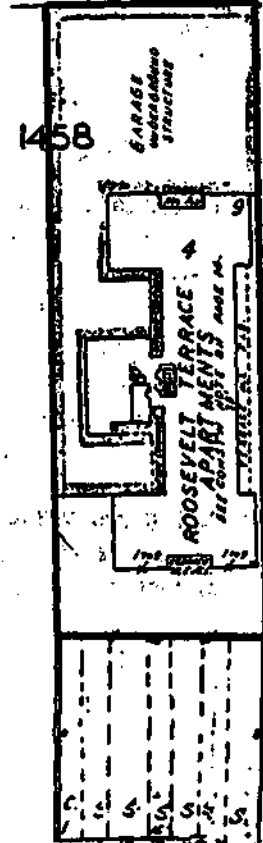

85th Street between 35th Avenue and 37th Avenue (East Side)

35-65 85th Street (a/k/a 85-01 37th Avenue)

Block/lot: 1459/40

Type: Apartment Building

Stories: 6 with basement

Style: Moderne (Post-World War II)

Date: 1955-56 [NB 3305-1955]

Architect: Michael M. Elkind

Developer: Irvson Realty Corp.

Designed by Michael M. Elkind and built in 1955-56, this six-story-and-basement building is one of several apartment buildings constructed in the post-World War II era of development in Jackson Heights. Located at the northeast corner of 37th Avenue and 85th Street, the building is planned with a broad and shallow recess along its avenue facade (there are no storefronts) and a narrower lightcourt at the center of the 85th Street facade; these recesses contain fire escapes. The brick facades have openings containing single and paired windows with two-over-two horizontal sash. On the 85th Street facade, continuous sill courses underscore the windows. The entrance is at the northern end of the street facade, set into a rectangular stuccoed recess. The metal-framed glass doors are flanked by a window-wall. Adjacent to the building, on 85th Street, is a driveway leading to the rear garage. The eastern elevation of the building is visible above the adjacent one-story building on 37th Avenue.

85th Street between 37th Avenue and Roosevelt Avenue (East Side)

37-01 85th Street

See: 85-02—85-30 37th Avenue

85th Street between 37th Avenue and Roosevelt Avenue (East Side)

CAMBRIDGE COURT

37-13—37-57 85th Street and 37-14—37-58 86th Street

Block/lots: 1473/71, 70, 64, 63, 57, 54, 49, 12, 16, 22, 23, 29, 30, 33

37-13 85th Street [1473/71]
37-21 85th Street [1473/70]
37-27 85th Street [1473/64]
37-35 85th Street [1473/63]
37-41 85th Street [1473/57]
37-49 85th Street [1473/54]
37-57 85th Street [1473/49]

37-14 86th Street [1473/12]
37-22 86th Street [1473/16]
37-28 86th Street [1473/22]
37-36 86th Street [1473/23]
37-42 86th Street [1473/29]
37-50 86th Street [1473/30]
37-58 86th Street [1473/33]

Type: Garden Apartments (14 buildings)
Stories: 4 with basement
Style: Neo-Georgian

Date: 1922*
Architect: George H. Wells
Developer: Jackson Heights Gardens Inc.

- *No. 37-13 85th Street — NB 8134-1922
- *No. 37-35 85th Street — NB 8135-1922
- *Nos. 37-21 and 37-27 85th Street — NB 8137-1922
- *Nos. 37-41 and 37-49 85th Street — NB 8138-1922
- *No. 37-57 85th Street — NB 8136-1922
- *No. 37-14 86th Street — NB 8141-1922
- *Nos. 37-22 and 37-28 86th Street — NB 8143-1922
- *No. 37-36 86th Street — NB 8140-1922
- *Nos. 37-42 and 37-50 86th Street — NB 8142-1922
- *No. 37-58 86th Street — NB 8139-1922

Cambridge Court, built in 1922 to designs by George H. Wells, is one of the early large, through-the-block, garden apartment complexes in Jackson Heights. It is the latest of the architect's projects located within the historic district. Occupying most of the block, the complex of fourteen four-story-and-basement buildings, each with a modified T-shaped plan, has seven attached buildings along each blockfront which are situated back-to-back across a common landscaped garden at the interior of the block.

Characteristic of the neo-Georgian style, the buildings are clad in red brick laid in Flemish bond and have stone and wood trim. The Georgian-inspired design of the complex is said to have been inspired by the freshman dormitories at Harvard University in Cambridge, Massachusetts. The seven buildings on each blockfront are arranged in an "A-B-B-A-B-B-A" pattern, in which the "A" buildings project slightly forward, creating a pavilion-like effect. While the "A" buildings have flat roofs capped by cornices and balustraded parapets, the intervening "B" buildings have sloping mansard roofs rising above cornices at the fourth story. Both the "A" and "B" types have projecting entrance porches, a hallmark of Wells's work, each with fluted stone pilasters (paired at the "B" type) supporting an entablature and topped by an iron railing. Other ornamental details include splayed lintels with keystones, keyed oval windows ("A"), gabled dormers with returns ("B"), and the articulation of the central stairhall bay of each building with a pseudo-Palladian window ("A") or pedimented gable ("B") at the top story.

Most of the original paneled wood-and-glass doors survive; all of the entrances have transoms and those in the "A" types have sidelights, as well. Nos. 37-49 85th Street and 37-42 86th Street retain the original

multi-pane double-hung wood sash windows. In 1991 three driveways were cut through the basement level of the buildings to connect the street and interior court, and a portion of the garden was converted into a parking lot. Handicap access ramps have been added to several of the buildings and, at No. 37-13 85th Street, a professional office has been installed.

Source: "Apartment House Completed at Jackson Heights," *New York Times*, April 22, 1923, p.2.

→

Cambridge Court

Block 1473 Lots 12, 16, 22, 23, 29, 30, 33, 49, 54, 57, 63, 64, 70 & 71

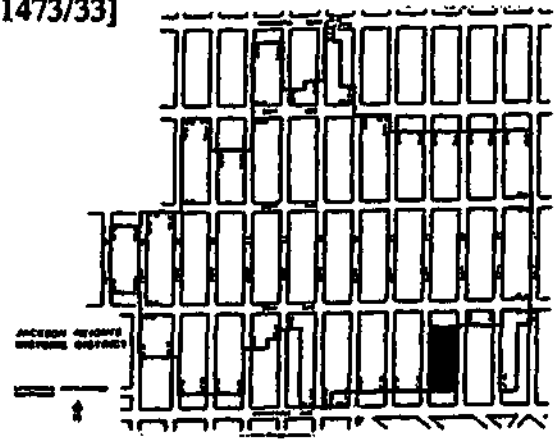
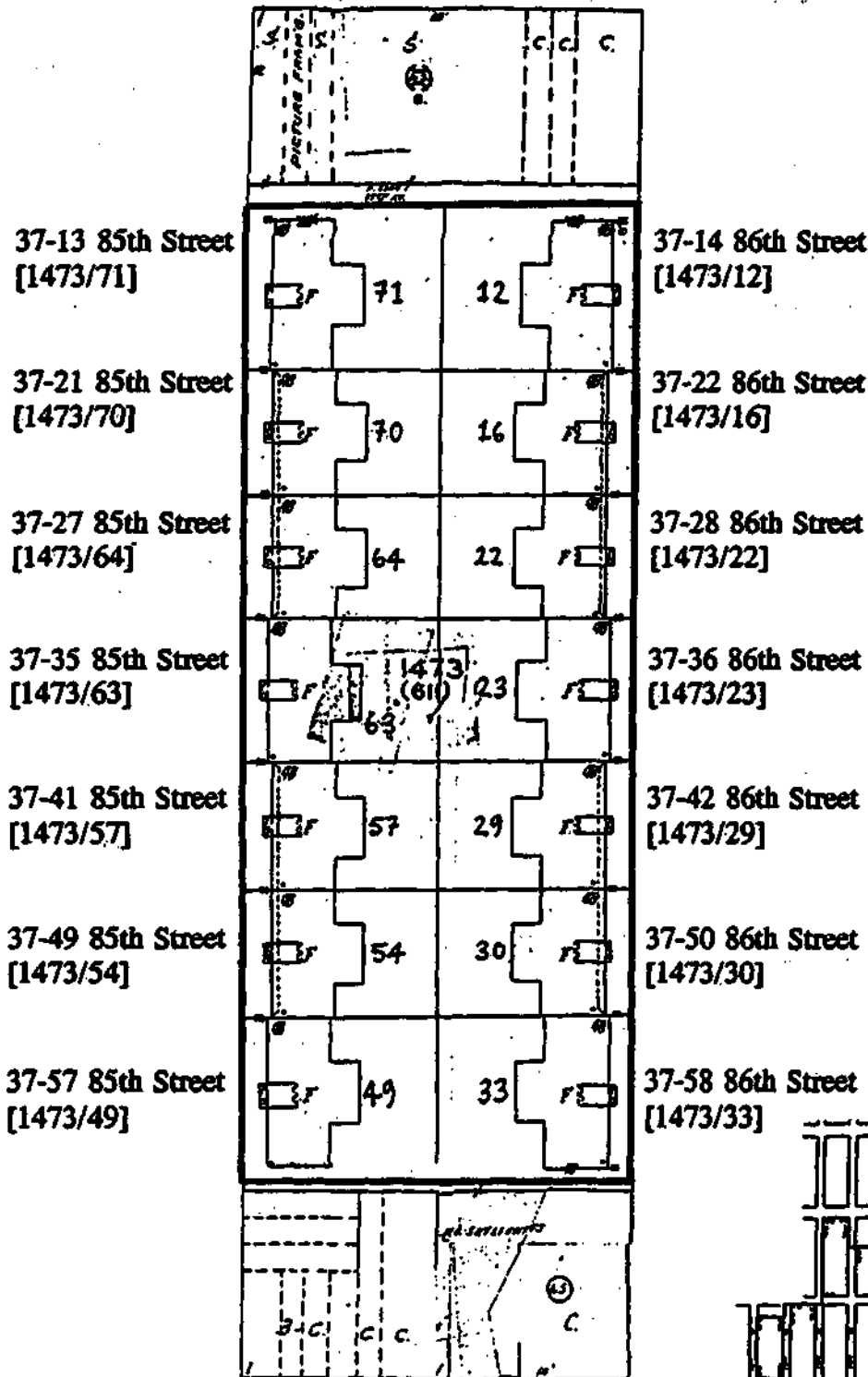

85TH STREET — West Side

85th Street between 34th Avenue and 35th Avenue (West Side)

34-14—34-52 85th Street

See: 34-11—34-51 84th Street

85th Street between 35th Avenue and 37th Avenue (West Side)

35-02 85th Street

See: 84-02—84-12 35th Avenue

85th Street between 35th Avenue and 37th Avenue (West Side)

35-16 85th Street

See: 35-15 84th Street

85th Street between 35th Avenue and 37th Avenue (West Side)

35-20—35-50 85th Street

See: 35-01—35-51 85th Street

85th Street between 37th Avenue and Roosevelt Avenue (West Side)

37-02 85th Street

See: 84-02—84-30 37th Avenue

85th Street between 37th Avenue and Roosevelt Avenue (West Side)

37-12—37-60 85th Street

See: 37-11—37-59 84th Street

86TH STREET — East Side

86th Street between 34th Avenue and 35th Avenue (East Side)

34-15—34-51 86th Street

Block/lots: 1447/65, 63, 61, 59, 57, 56, 53, 52, 49, 47

34-15 86th Street [1447/65]

34-19 86th Street [1447/63]

34-23 86th Street [1447/61]

34-27 86th Street [1447/59]

34-31 86th Street [1447/57]

34-35 86th Street [1447/56]

34-39 86th Street [1447/53]

34-43 86th Street [1447/52]

34-47 86th Street [1447/49]

34-51 86th Street [1447/47]

Type: Semi-Detached Houses
(10 buildings)

Stories: 3

Style: Neo-Georgian

Date: 1926-27*

Architect: Robert Tappan

Developer: Queensboro Corp.

*Nos. 34-15 and 34-19 86th Street — NB 12298-1926

*Nos. 34-23 and 34-27 86th Street — NB 12297-1926

*Nos. 34-31 and 34-35 86th Street — NB 12296-1926

*Nos. 34-39 and 34-43 86th Street — NB 12295-1926

*Nos. 34-47 and 34-51 86th Street — NB 12294-1926

Built in 1926-27 to designs by Robert Tappan, this group of ten houses is characteristic of many similar groups of attached and semi-detached houses built in Jackson Heights during the second half of the 1920s. Located on 86th Street between 34th and 35th avenues, the houses are arranged as five double houses. These houses are very similar to the five double houses at **34-14—34-50 87th Street** which were also designed by Tappan and built at roughly the same time; the two groups are situated back-to-back on the block. Each house has an attached garage at the side and shares a short driveway with the neighboring house in the adjacent pair. All of the houses have front gardens.

The five double houses on 86th Street are arranged in an overall symmetrical pattern ("A-B-A-B-A") with the two houses in each pair designed as mirror images. The pattern in the facade designs is created by the alternating roof profiles and by the form and placement of the projecting entrance porches. The "A" pairs have gabled roofs with end chimneys and, at the center of the pair, a shared entrance porch with a hipped roof and doors set to the sides. The "B" pairs have hipped roofs with a chimney at the center and separate entrance porches with segmental pediments.

Of red brick with white trim, the houses are largely neo-Georgian in style. Elements typical of that style include the slate roofs with dormers and prominent chimneys; the classically-inspired entrance porches; the brickwork suggestive of quoins; the arched window openings at the side facades of the "A" houses; the wooden shutters at the windows; the multi-pane double-hung sash, in single and tripartite configurations; and the brick garden walls between the houses and flanking the driveways.

Alterations include replacement entrance and garage doors, although many of these elements, as well as most of the original windows, remain intact. At the rear, the houses have individual gardens.



34-15—34-51 86th Street

Block 1447 Lots 47, 49, 52, 53, 56, 57, 59, 61, 63, & 65

- 34-15 86th Street [1447/65]
- 34-19 86th Street [1447/63]
- 34-23 86th Street [1447/61]
- 34-27 86th Street [1447/59]
- 34-31 86th Street [1447/57]
- 34-35 86th Street [1447/56]
- 34-39 86th Street [1447/53]
- 34-43 86th Street [1447/52]
- 34-47 86th Street [1447/49]
- 34-51 86th Street [1447/47]

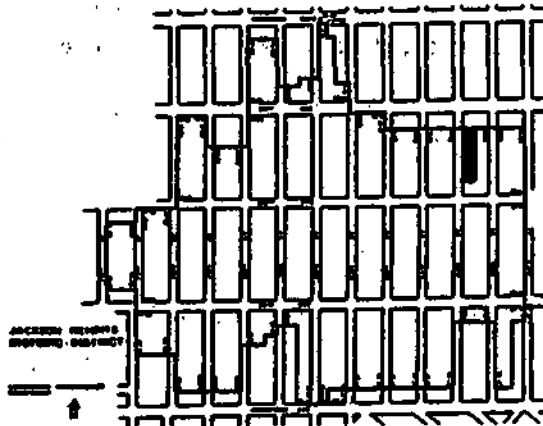
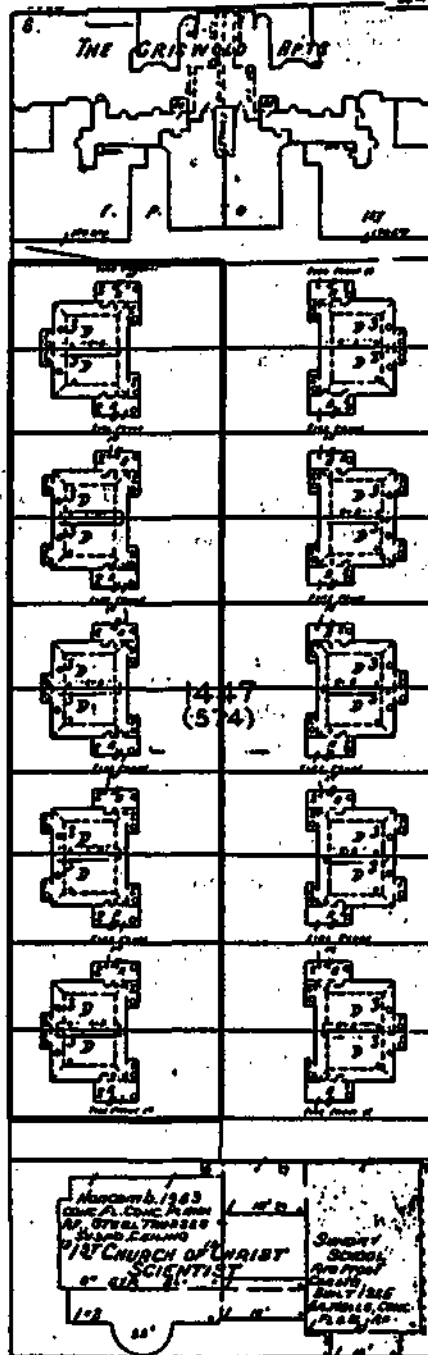

86th Street between 35th Avenue and 37th Avenue (East Side)

35-15, 35-29, 35-37, 35-41, 35-45, 35-49 86th Street

Block/lots: 1460/68, 60, 56, 54, 52, 50

35-15 86th Street [1460/68]

35-29 86th Street [1460/60]

35-37 86th Street [1460/56]

35-41 86th Street [1460/54]

35-45 86th Street [1460/52]

35-49 86th Street [1460/50]

Type: Detached Houses (6 of 12)

Stories: 3

Style: Anglo-American Garden Home

Date: 1926-27*

Architect: Charles Stidolph

Developer: C. McShane

*No. 35-15 86th Street — NB 20035-1926

*No. 35-29 86th Street — NB 20026-1926

*No. 35-37 86th Street — NB 20023-1926

*No. 35-41 86th Street — NB 20021-1926

*No. 35-45 86th Street — NB 20019-1926

*No. 35-49 86th Street — NB 20017-1926

These six detached houses of brick, located on the east side of 86th Street between 35th and 37th Avenues, survive from a group of twelve houses built in 1927 to designs by Queens architect Charles Stidolph. Although the only examples of detached single-family houses within the historic district, they are similar to the many groups of attached and semi-detached houses built in Jackson Heights during the second half of the 1920s.

The design of the houses is derived primarily from the neo-Georgian style, exemplified by the red brick facing, steeply pitched gables with prominent end chimneys, and shed dormers. The red roof tiles, however, are Mediterranean in inspiration. The houses follow the same basic design in their four-square massing; all have projecting sun porches at the front and entrance porches with short stoops. However, the houses vary in their roof profiles and entrance placement, comprising three alternating models.

Nos. 35-15 and 35-41 each have a front-facing peaked gable end and a shallow-roofed sun porch with an attached and recessed entrance porch. Nos. 35-29 and 35-45 also have front-facing peaked gable ends, but the roof pitch is steeper; the entrance porches are placed to the side of the house; and the sun porches have pent roofs. Nos. 35-37 and 35-49 have side-facing jerkin gables, large front-facing dormers, and front entrance porches which project beyond the sun porches. Most of the houses retain their original multi-pane wood-framed windows, both six-over-six and casement-with-transom types. Some porch windows have been changed. At No. 35-29, a second entrance porch has been added to the front to accommodate a professional office.

Behind and to the north of each house is a detached one-bay garage, clearly visible from the street. Of red brick with red tile roofs, the garages are designed to match the style of the houses. The houses all have front gardens.



35-15, 35-29, 35-37, 35-41, 35-45 & 35-49 86th Street

Block 1460 Lots 50, 52, 54, 56, 60 & 68

35-15 86th Street [1460/68]

35-29 86th Street [1460/60]

35-37 86th Street [1460/56]

35-41 86th Street [1460/54]

35-45 86th Street [1460/52]

35-49 86th Street [1460/50]

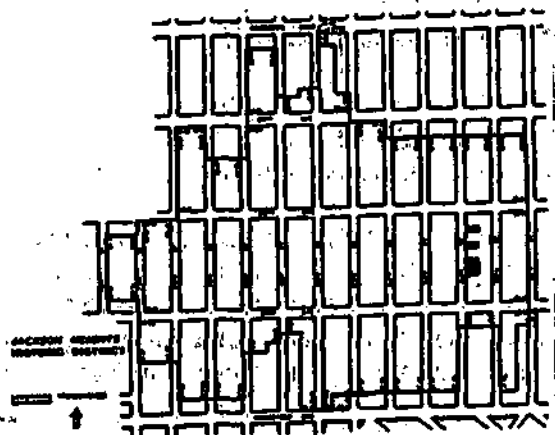
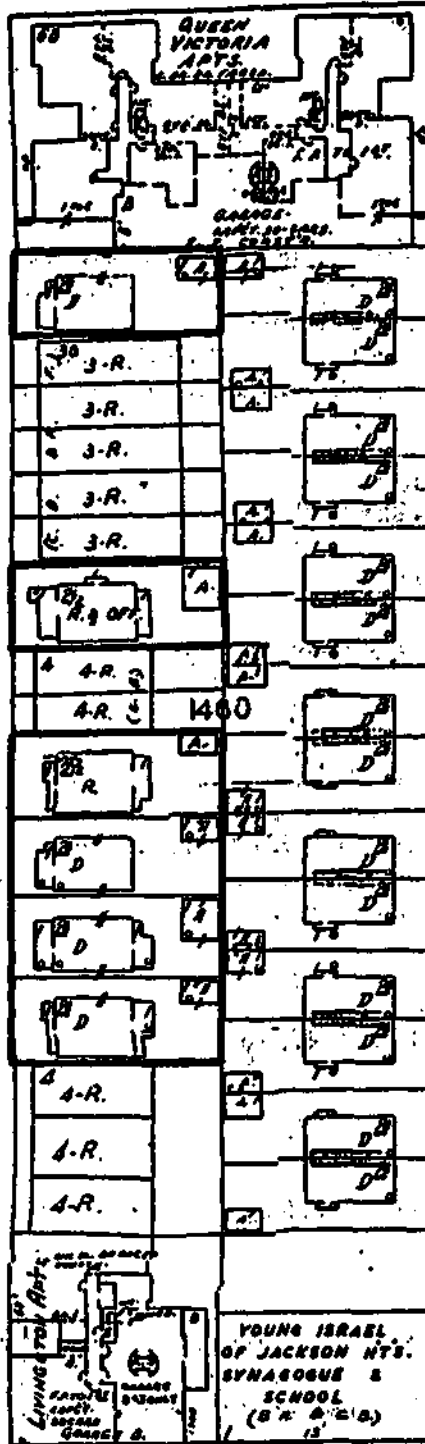

86th Street between 35th Avenue and 37th Avenue (East Side)

35-17—35-25 86th Street

Block/lots: 1460/167, 166, 65, 63, 62

35-17 86th Street [1460/167]

35-19 86th Street [1460/166]

35-21 86th Street [1460/65]

35-23 86th Street [1460/63]

35-25 86th Street [1460/62]

Type: Attached Houses (5 buildings)

Stories: 4

Style: Post-Modern

Date: 1988-90 [NB 1349-1988]

Architect: Fakler/Eliason Assoc.

Developer: Acapulco Realty Corp.

This group of five four-story brick houses, designed by the firm of Fakler/Eliason Associates and completed in 1990, is one of three similar groups on this block of 86th Street. The group replaced three of twelve single-family houses built in 1927 to the designs of Charles Stidolph (see 35-15 86th Street). The facade of each house in the group incorporates traditional architectural motifs: red brick, pseudo-Palladian windows, and pediments at the roofline. Each house has a garage entrance at its base. →

35-33—35-35 86th Street

Block/lots: 1460/59, 58

35-33 86th Street [1460/59]

35-35 86th Street [1460/58]

Type: Attached Houses (2 buildings)

Stories: 4

Style: Post-Modern

Date: 1987-92 [NB 1579-1987; C of O 1992]

Architect: Fakler/Eliason Assoc.

Developer: Acapulco Realty Corp.

This pair of two four-story brick houses, designed by the firm of Fakler/Eliason Associates and completed in 1992, is one of three similar groups on this block of 86th Street. This pair replaced one of twelve single-family houses built in 1927 to the designs of Charles Stidolph (see 35-15 86th Street). The facades of the houses incorporate traditional architectural motifs: red brick, a blind arch at the top story, and a pediment at the roofline. Each house has a garage entrance at its base. →

35-53—35-57 86th Street

Block/lots: 1460/49, 47, 46

35-53 86th Street [1460/49]

35-55 86th Street [1460/47]

35-57 86th Street [1460/46]

Type: Attached Houses (3 buildings)

Stories: 4

Style: Post-Modern

Date: 1988-91 [NB 1582-1987]

Architect: Fakler/Eliason Assoc.

Developer: Acapulco Realty Corp.

This group of three four-story brick houses, designed by the firm of Fakler/Eliason Associates and completed in 1991, is one of three similar groups on this block of 86th Street. The building replaced two of twelve single-family houses built in 1927 to the designs of Charles Stidolph (see 35-15 86th Street). The facades of the houses incorporate traditional architectural motifs: red brick, blind arches, pseudo-Palladian windows, and pediments at the roofline. Each house has a garage entrance at its base. →

35-17—35-25, 35-33, 35-35 and 35-53—35-57 86th Street

Block 1460 Lots 46, 47, 49, 58, 59, 62, 63, 65, 166 & 167

- 35-17 86th Street [1460/167]
- 35-19 86th Street [1460/166]
- 35-21 86th Street [1460/65]
- 35-23 86th Street [1460/63]
- 35-25 86th Street [1460/62]

- 35-33 86th Street [1460/59]
- 35-35 86th Street [1460/58]

- 35-53 86th Street [1460/49]
- 35-55 86th Street [1460/47]
- 35-57 86th Street [1460/46]

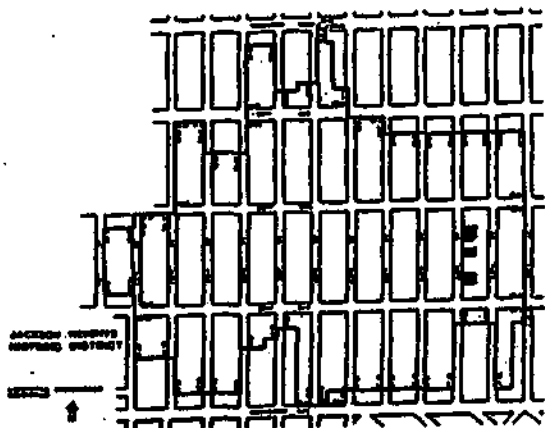
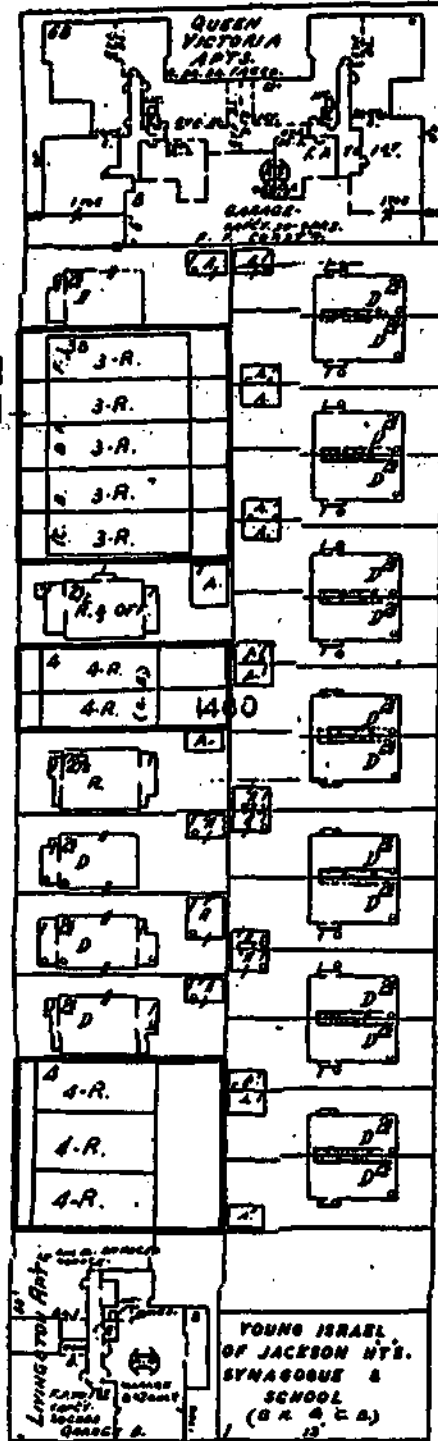

86th Street between 35th Avenue and 37th Avenue (East Side)

LIVINGSTON APARTMENTS

35-65 86th Street (a/k/a 86-01—86-13 37th Avenue)

Block/lot: 1460/40

Type: Apartment Building

Stories: 6 with basement

Style: Neo-Georgian (Post-World War II)

Date: 1952-53 [NB 4757-1952]

Architect: Schulman & Soloway

Owners: 86th St. Apts. Inc.

Designed by Schulman & Soloway and built in 1952-53, the six-story-and-basement Livingston Apartments is one of several apartment buildings constructed in the post-World War II era of development in Jackson Heights. The building is located at the northeast corner of 37th Avenue and 86th Street and is planned with a deep lightcourt that serves as an entrance court in the 86th Street facade. The brick facade is unadorned, except for brick quoins at the corners and a beltcourse at the base. (There are no storefronts on the avenue elevation.) The entrance, set into a veined marble enframingent, consists of paneled wood double-doors with multi-pane sash and wide sidelights. Its steps and porch have iron railings. The eastern elevation of the building is visible above the adjacent one-story building on 37th Avenue. There is a basement garage.

86th Street between 37th Avenue and Roosevelt Avenue (East Side)

37-01—37-09 86th Street

See: 86-02—86-20 37th Avenue

86TH STREET — West Side

86th Street between 34th Avenue and 35th Avenue (West Side)

34-16—34-52 86th Street

Block/lots: 1446, 13, 15, 18, 19, 22, 23, 25, 28, 29, 31

34-16 86th Street [1446/13]

34-20 86th Street [1446/15]

34-24 86th Street [1446/18]

34-28 86th Street [1446/19]

34-32 86th Street [1446/22]

34-36 86th Street [1446/23]

34-40 86th Street [1446/25]

34-44 86th Street [1446/28]

34-48 86th Street [1446/29]

34-52 86th Street [1446/31]

Type: Semi-Detached Houses (10 buildings)

Stories: 2 and one-half

Style: Anglo-American Garden Home

Date: 1927*

Architect: Rogers & Haneman

Developer: Jackson Heights Apt. Corp.

*Nos. 34-16 and 34-20 86th Street —
NB 15217-1926

*Nos. 34-24 and 34-28 86th Street —
NB 15216-1926

*No. 34-32 86th Street — NB 15218-1926

*No. 34-36 86th Street — NB 15215-1926

*Nos. 34-40 and 34-44 86th Street —
NB 15214-1926

*Nos. 34-48 and 34-52 86th Street —
NB 15213-1926

Built in 1927 to designs by Rogers & Haneman, this group of ten houses is characteristic of many similar groups of attached and semi-detached houses built in Jackson Heights during the second half of the 1920s. Located on 86th Street between 34th and 35th avenues, the houses are arranged as five double-houses with paired garages which are located between them at the rear of the lots. Each set of garages is reached by a driveway which is shared by the two neighboring houses. All the houses have front gardens.

The double houses are arranged in an overall symmetrical pattern with alternating hipped ("a") and gabled ("b") roof profiles creating a mirror-image "a-b/b-a/b-b/a-b/b-a" formation in the group. However, the facade designs vary in the form and configuration of their window bays and openings, resulting in a different pattern of repetition.

The style of the houses is inspired by the picturesque cottages of the English countryside. Elements which evoke this architectural quality include the tapestry brick facing, steeply-pitched slate roofs with dormers and chimneys, projecting entrance porches with flared sides, sloping brick garden walls, arched openings, brick relieving arches, and multi-pane casement windows. The side facades of the houses are similar to the fronts, and are visible from the street. The garages are also visible from the street; they are similar in design to the houses, with relieving arches and gabled roofs covered in slate tiles. Many original multi-pane casement and double-hung wood windows survive. Alterations include the panning of a few window frames and the replacement of garage doors.

→

34-16—34-52 86th Street

Block 1446 Lots 13, 15, 18, 19, 22, 23, 25, 28, 29, 31

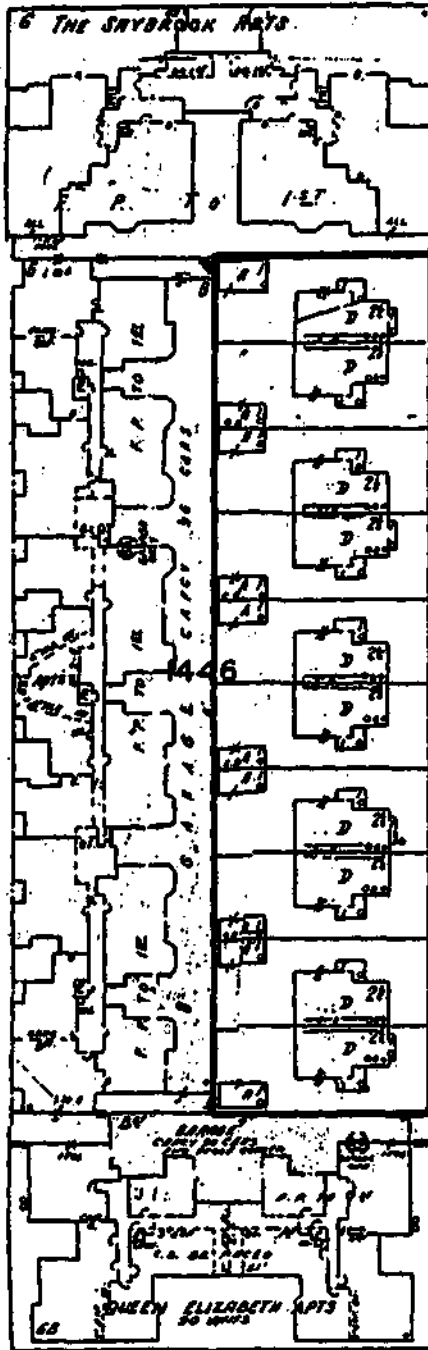

- 34-16 86th Street [1446/13]
- 34-20 86th Street [1446/15]
- 34-24 86th Street [1446/18]
- 34-28 86th Street [1446/19]
- 34-32 86th Street [1446/22]
- 34-36 86th Street [1446/23]
- 34-40 86th Street [1446/25]
- 34-44 86th Street [1446/28]
- 34-48 86th Street [1446/29]
- 34-52 86th Street [1446/31]

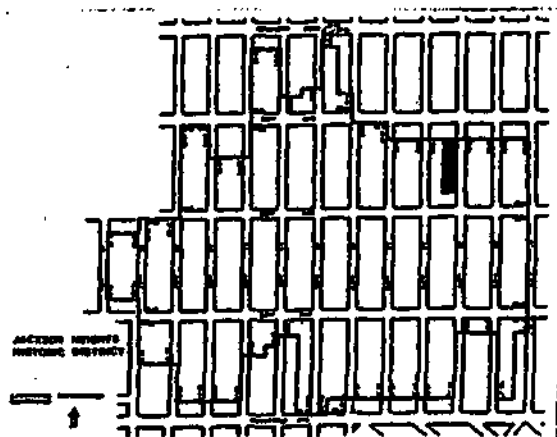

86th Street between 35th Avenue and 37th Avenue (West Side)

35-02 86th Street

See: 35-01—35-51 85th Street

86th Street between 37th Avenue and Roosevelt Avenue (West Side)

37-02 86th Street

See: 85-02—85-30 37th Avenue

86th Street between 37th Avenue and Roosevelt Avenue (West Side)

37-14—37-58 86th Street

See: 37-13—37-57 85th Street

87TH STREET — East Side

87th Street between 34th Avenue and 35th Avenue (East Side)

34-13—34-49 87th Street

Block/lots: 1448/59, 58, 57, 56, 55, 54, 52, 51, 50, 49, 47, 46, 45, 44, 43, 41

34-13 87th Street [1448/59]

34-15 87th Street [1448/58]

34-17 87th Street [1448/57]

34-19 87th Street [1448/56]

34-21 87th Street [1448/55]

34-23 87th Street [1448/54]

34-27 87th Street [1448/52]

34-29 87th Street [1448/51]

34-33 87th Street [1448/50]

34-35 87th Street [1448/49]

34-39 87th Street [1448/47]

34-41 87th Street [1448/46]

34-43 87th Street [1448/45]

34-45 87th Street [1448/44]

34-47 87th Street [1448/43]

34-49 87th Street [1448/41]

Type: Attached & Semi-Detached Houses
(16 buildings)

Stories: 2 and one-half

Style: Anglo-American Garden Home

Date: 1925*

Architect: Robert Tappan

Developer: Queensboro Corp.

*Nos. 34-13, 34-15, 34-17, 34-19, 34-21, and 34-23 87th Street— NB 125-1925

*Nos. 34-27, 34-29, 34-33, and 34-35 87th Street — NB 126-1925

*Nos. 34-39, 34-41, 34-43, 34-45, 34-47, and 34-49 87th Street — NB 127-1925

Built in 1925 to designs by Robert Tappan, this group of sixteen houses is characteristic of many similar groups of attached and semi-detached houses built in Jackson Heights during the second half of the 1920s. Located on 87th Street, between 34th and 35th avenues, the houses are arranged as two clusters of six houses each, flanking one central cluster of four houses. Paired garages (one per house) are located at the rear and reached by a common driveway entered and exited at the ends of the blockfront. The group is situated back-to-back with the group at 34-14—34-50 88th Street, designed by C.L. Varrone and built in 1925-26; the two groups together are organized on a block plan, with landscaped open space at the interior of the block. All of the houses have front gardens.

The clusters are symmetrical in their designs. The six-house groups follow a mirror-image "a-b-b-b-b-a" pattern in which the "a" houses have projecting gabled fronts and the "b" houses have projecting entrance porches alternating in placement. This produces a pavilion-like effect and creates the impression that each cluster is a larger single entity. The cluster of four "c" houses at the center is also symmetrical, having a mirror-image configuration in which each two houses share between them a projecting gabled section containing the entrances to both houses.

Faced in red brick, the houses are neo-Georgian in style. This style is characterized by such details as the peaked and gabled slate roofs with shed dormers; the round-arched front doors at the "a" houses, and the arched doorways with fanlights in the "c" houses; the hip-roofed entrance porches of the "b" houses; the bricks laid to suggest quoins; the prominent chimneys; and the multi-pane windows.

The side and rear facades of the houses are partially visible from the street. The houses retain most of the original windows and many of the original wood-and-glass doors. Storm windows and doors have been added on many houses. The paired garages have peaked slate roofs like the houses. Over time, garages appear to have been extended to accommodate larger cars.



34-13—34-49 87th Street

Block 1448 Lots 41, 43-47, 49-52, 54-59

- 34-13 87th Street [1448/59]
- 34-15 87th Street [1448/58]
- 34-17 87th Street [1448/57]
- 34-19 87th Street [1448/56]
- 34-21 87th Street [1448/55]
- 34-23 87th Street [1448/54]

- 34-27 87th Street [1448/52]
- 34-29 87th Street [1448/51]
- 34-33 87th Street [1448/50]
- 34-35 87th Street [1448/49]

- 34-39 87th Street [1448/47]
- 34-41 87th Street [1448/46]
- 34-43 87th Street [1448/45]
- 34-45 87th Street [1448/44]
- 34-47 87th Street [1448/43]
- 34-49 87th Street [1448/41]

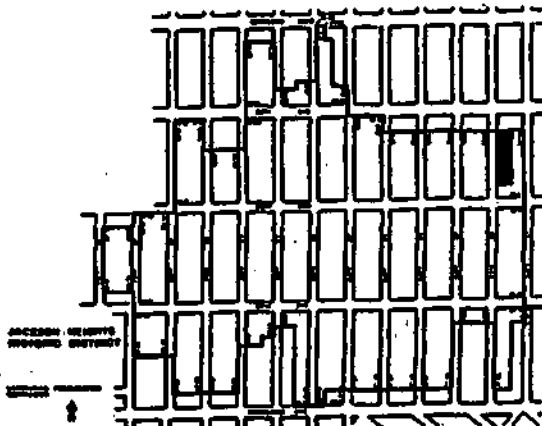
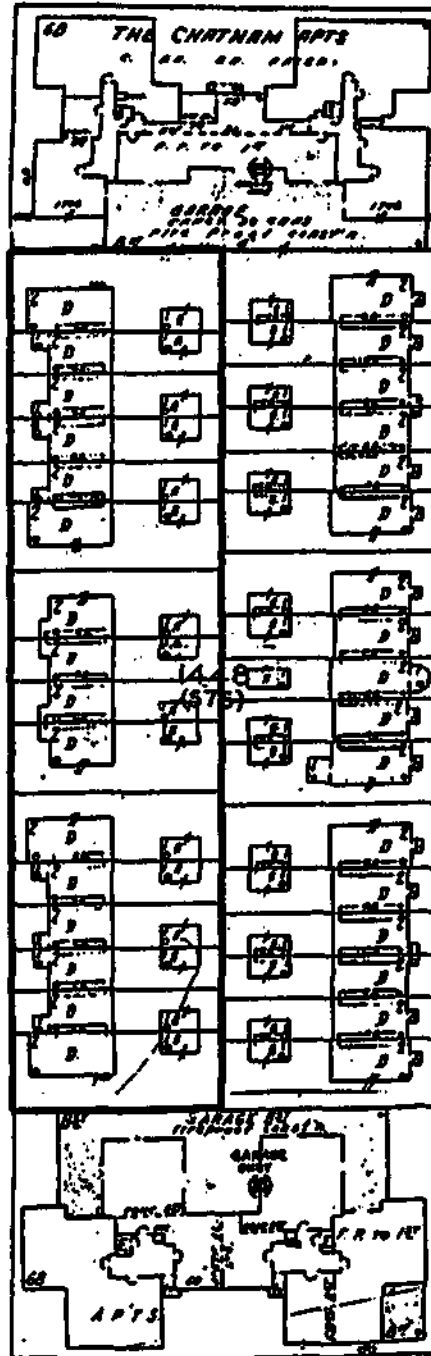

87th Street between 35th Avenue and 37th Avenue (East Side)

THE JACKSONIAN APARTMENTS

35-01—35-05 87th Street (a/k/a 87-02 35th Avenue)

Block/lot: 1461/1

Type: Apartment Building
Stories: 6 with basement
Style: Neo-Georgian

Date: 1936 [NB 170-1936]
Architect: Cohn Brothers
Developer: Jacksonian Apts., Inc.

Built in 1936 to designs by the Cohn Brothers, the six-story-and-basement Jacksonian Apartments is among the later apartment buildings erected in the historic district. Typical of that phase of development, the building occupies an end-block site on 35th Avenue and is planned with a large, recessed entrance court at the front (oriented toward 87th Street). The building shares its 35th Avenue frontage with the **Madison Apartments** to the east, also designed by the firm of Cohn Brothers and built in the following year.

Neo-Georgian in style, the building is faced in brick (including random rough-faced bricks) with white trim and is similar in its design to two buildings on the north side of 35th Avenue, several blocks to the west of the Jacksonian: the **Georgian Gardens**, designed by the Cohn firm in 1935-36, and the **Senate Gardens**, designed by Seelig & Finkelstein in 1937. Elements of the design which are typical of the neo-Georgian style include the door surround with fluted pilasters, leaded sidelights, and a false fanlight topped with a triangular pediment; brickwork imitating quoins and brick pilasters with stone bases and capitals; brick bandcourses suggestive of entablatures; windows set into relieving arches of brick headers with stone keystones; and, at the roofline, parapets cut out to accommodate urns and brick pediments pierced by oculi. Iron balconettes front some second-story bays.

87th Street between 35th Avenue and 37th Avenue (East Side)

35-15—35-61 87th Street

Block/lots: 1461/78, 77, 76, 74, 72, 71, 70, 69, 67, 65, 64, 63, 62, 60, 58, 57, 56, 54

35-15 87th Street [1461/78]
35-17 87th Street [1461/77]
35-19 87th Street [1461/76]
35-21 87th Street [1461/74]
35-25 87th Street [1461/72]
35-27 87th Street [1461/71]
35-29 87th Street [1461/70]
35-33 87th Street [1461/69]
35-35 87th Street [1461/67]

35-39 87th Street [1461/65]
35-41 87th Street [1461/64]
35-43 87th Street [1461/63]
35-45 87th Street [1461/62]
35-47 87th Street [1461/60]
35-51 87th Street [1461/58]
35-53 87th Street [1461/57]
35-55 87th Street [1461/56]
35-57—35-61 87th Street [1461/54]

Type: Attached & Semi-Detached Houses
(18 buildings)

Stories: 3

Style: Anglo-American Garden Home

Date: 1925*

Architect: C.F. McAvoy

Developer: Queensboro Corp.

*Nos. 35-15, 35-17, 35-19, and 35-21 87th Street — NB 100-1925

*Nos. 35-25, 35-27, 35-29, 35-33, and 35-35 87th Street — NB 101-1925

*Nos. 35-39, 35-41, 35-43, 35-45 and 35-47 87th Street — NB 98-1925

*Nos. 35-51, 35-53, 35-55, and 35-57—35-61 87th Street — NB 99-1925

Built in 1925 to designs by C.F. McAvoy, this group of eighteen houses is characteristic of many similar groups of attached and semi-detached houses built in Jackson Heights during the second half of the 1920s. Located on the east side of 87th Street between 35th and 37th avenues, the houses are grouped into two clusters of five houses flanked at each end by a cluster of four houses. The group is situated back-to-back with a group of houses on the west side of 88th Street (Nos. 35-14—35-56), designed by Robert Tappan, with which it shares a planned block interior. Matching paired garages (one per house) are located at the rear and reached by a common driveway. The houses have small front yards and stoops.

This group is almost identical to an earlier group of houses by the McAvoy firm in the block to the south on 87th Street. Like the earlier row, these four clusters follow a symmetrical ("A-B-B-A") pattern in their overall configuration, and each cluster is, in turn, organized in mirror-image formation ("a-b-b-a") and ("a-b-c-b-a"). These symmetrical configurations produce the effect that each cluster is a larger single entity. The mirror-image placement of the entrances and the alternating roof profiles reinforce the symmetry of the group, and the overall consistency of the pattern gives the blockfront a cohesive design.

The design of the houses is derived largely from the neo-Georgian style. Elements typical of that style include the red brick facing with white trim, the steeply pitched slate roofs with prominent gables ("a" and "c" houses) and shed dormers, and the wood shutters at the windows. Different entrance treatments create variety in the houses: gabled entrance porches with columns or pilasters ("a" houses); stone surrounds with entablatures ("c" houses); slate-roofed canopies over the doorways ("b" houses in the five-house clusters); and trellised door surrounds ("b" houses in the four-house clusters). In addition, the "a" houses in the four-house clusters have bracketed window boxes at the second story. The side facades of the end houses are visible from the street.

Most of the six-over-six double-hung wood sash windows survive, as do most of the paneled wood doors with multi-pane upper sections. The end units at Nos. 35-21 and 35-25 have identical greenhouses that appear to be historic.

→

35-15—35-61 87th Street

Block 1461 Lots 54, 56-58, 60, 62-65, 67, 69-72, 74, 76-78

- 35-15 87th Street [1461/78]
- 35-17 87th Street [1461/77]
- 35-19 87th Street [1461/76]
- 35-21 87th Street [1461/74]

- 35-25 87th Street [1461/72]
- 35-27 87th Street [1461/71]
- 35-29 87th Street [1461/70]
- 35-33 87th Street [1461/69]
- 35-35 87th Street [1461/67]

- 35-39 87th Street [1461/65]
- 35-41 87th Street [1461/64]
- 35-43 87th Street [1461/63]
- 35-45 87th Street [1461/62]
- 35-47 87th Street [1461/60]

- 35-51 87th Street [1461/58]
- 35-53 87th Street [1461/57]
- 35-55 87th Street [1461/56]
- 35-57—35-61 87th Street [1461/54]

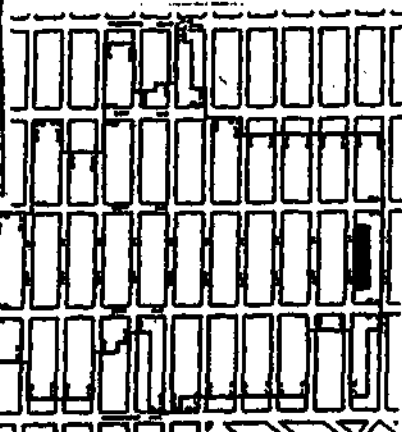
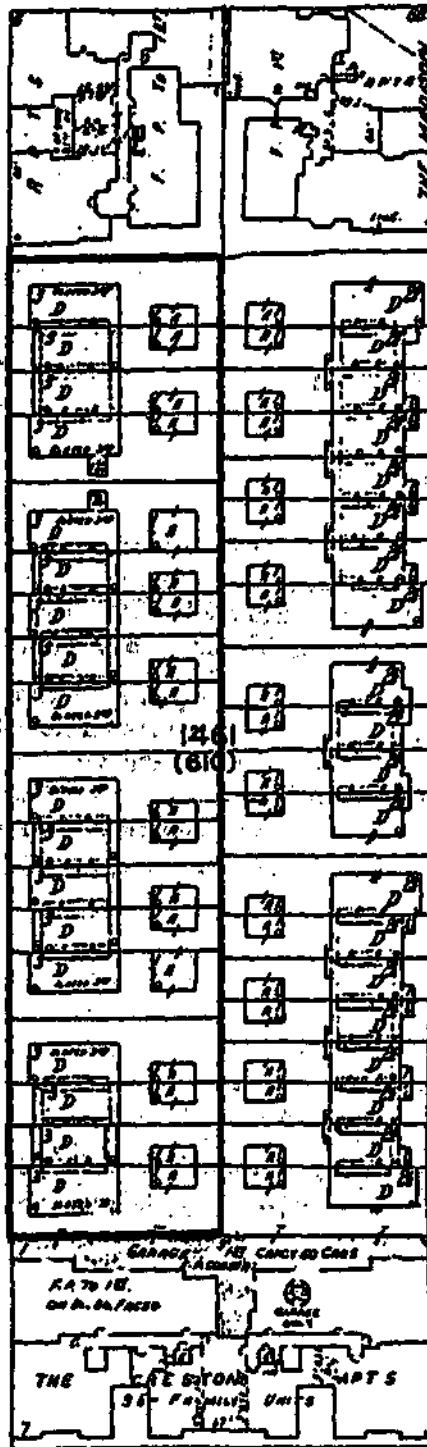

JACKSON HEIGHTS HISTORIC DISTRICT

87th Street between 37th Avenue and Roosevelt Avenue (East Side)

37-01 87th Street

See: 87-02—87-10 37th Avenue

87th Street between 37th Avenue and Roosevelt Avenue (East Side)

37-11—37-57 87th Street

Block/lots: 1475/71, 70, 69, 68, 67, 65, 64, 63, 62, 61, 59, 58, 57, 56, 55, 52, 51, 50, 49, 47

37-11—37-13 87th Street [1475/71]

37-15 87th Street [1475/70]

37-17 87th Street [1475/69]

37-19 87th Street [1475/68]

37-21 87th Street [1475/67]

37-25 87th Street [1475/65]

37-27 87th Street [1475/64]

37-29 87th Street [1475/63]

37-31 87th Street [1475/62]

37-33 87th Street [1475/61]

37-37 87th Street [1475/59]

37-39 87th Street [1475/58]

37-41 87th Street [1475/57]

37-43 87th Street [1475/56]

37-45 87th Street [1475/55]

37-49 87th Street [1475/52]

37-51 87th Street [1475/51]

37-53 87th Street [1475/50]

37-55 87th Street [1475/49]

37-57 87th Street [1475/47]

Type: Attached & Semi-Detached Houses
(20 buildings)

Stories: 3

Style: Anglo-American Garden Home

Date: 1924*

Architect: C.F. McAvoy

Developer: Queensboro Corp.

*Nos. 37-11—37-13, 37-15, 37-17, 37-19, and 37-21 87th Street — NB 328-1924

*Nos. 37-25, 37-27, 37-29, 37-31, and 37-33 87th Street — NB 327-1924

*Nos. 37-37, 37-39, 37-41, 37-43, and 37-45 87th Street — NB 326-1924

*Nos. 37-49, 37-51, 37-53, 37-55, and 37-57 87th Street — NB 329-1924

Built in 1924 to designs by C.F. McAvoy, this group of twenty houses was the first of many similar groups of attached and semi-detached houses built in Jackson Heights during the second half of the 1920s. Located on the east side of 87th Street between Roosevelt and 37th avenues, the houses are grouped into four clusters of five houses each. The houses have terraced front yards and steps. Basement-level garages are located at the rear of each house and are reached by a common driveway.

The group is almost identical to a slightly later group of houses by the McAvoy firm in the next block north on 87th Street. The four clusters follow a symmetrical ("A-B-B-A") pattern in their overall configuration, and each cluster is, in turn, organized in mirror-image formation ("a-b-a-b-a") with slight variations in the models. The overall consistency of the pattern gives the blockfront a cohesive design.

The design of the houses is derived largely from the neo-Georgian style. Elements typical of that style include the red brick facing with white trim; the steeply pitched red tile roofs ("A" clusters) and slate roofs ("B" clusters); the prominent front-facing gables ("a" houses) and shed dormers ("b" houses); and the wood shutters at the windows. The center "a" house of the "A" cluster has a jerkin-head gable instead of a peaked gable. Different entrance treatments create further variety in the houses: gabled entrance porches with pilasters (outer "a" houses); stone surrounds with entablatures (center "a" houses); header brick surrounds ("b" houses in "A" clusters); and slate-roofed canopies over the doorways ("b" houses in "B" clusters). In addition, the outer "a" houses in the "A" clusters had bracketed window boxes at the second story (only the brackets remain). The side facades of the end houses are visible from the street and have projecting chimneys and large shed dormers.

Some of the six-over-six double-hung wood sash windows survive, as do many of the paneled wood doors with multi-pane upper sections. Many shutters have been removed. No. 37-49 has a one-story addition at the side and a one-story addition spans the end units of Nos. 37-37 and 37-33. There have been numerous alterations to the front yards, steps, and retaining walls.

→

37-11—37-57 87th Street

Block 1475 Lots 47, 49-52, 55-59, 61-65. & 67-71

- [1475/71] 37-11 87th Street
- [1475/70] 37-15 87th Street
- [1475/69] 37-17 87th Street
- [1475/68] 37-19 87th Street
- [1475/67] 37-21 87th Street

- [1475/65] 37-25 87th Street
- [1475/64] 37-27 87th Street
- [1475/63] 37-29 87th Street
- [1475/62] 37-31 87th Street
- [1475/61] 37-33 87th Street

- [1475/59] 37-37 87th Street
- [1475/58] 37-39 87th Street
- [1475/57] 37-41 87th Street
- [1475/56] 37-43 87th Street
- [1475/55] 37-45 87th Street

- [1475/52] 37-49 87th Street
- [1475/51] 37-51 87th Street
- [1475/50] 37-53 87th Street
- [1475/49] 37-55 87th Street
- [1475/47] 37-57 87th Street

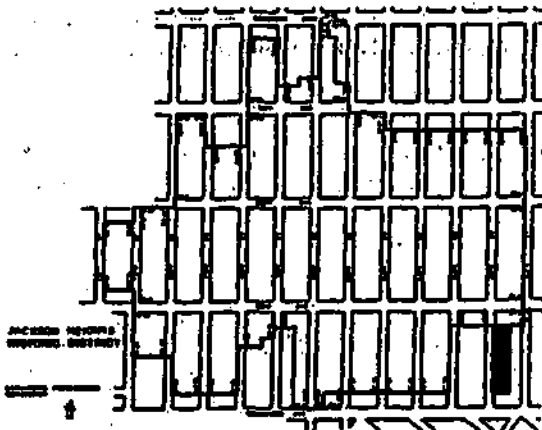
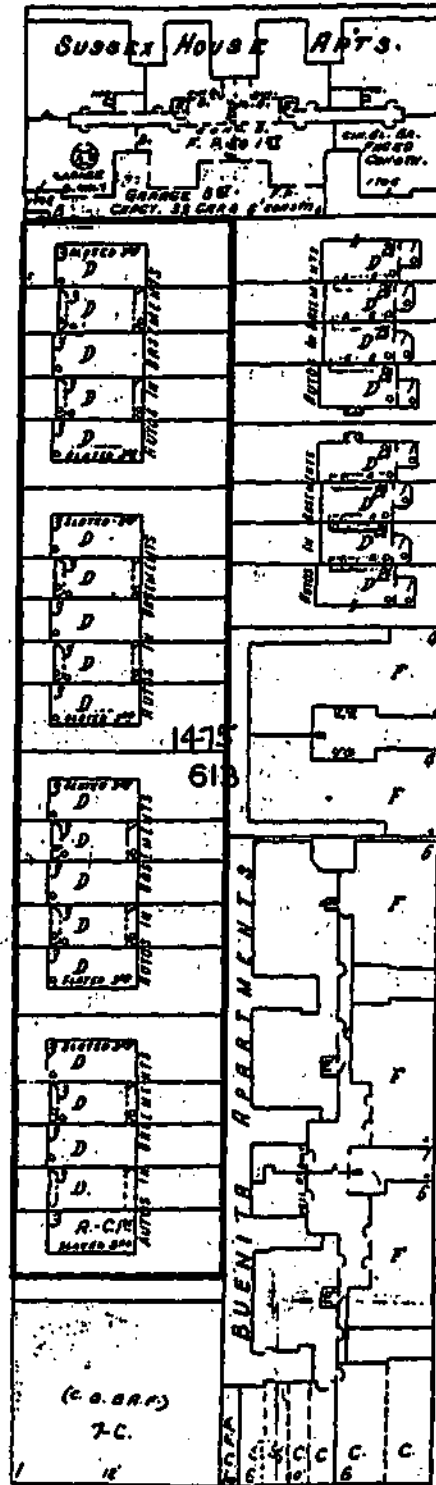

87TH STREET — West Side

87th Street between 34th Avenue and 35th Avenue (West Side)

34-14—34-50 87th Street

Block/lots: 1447/12, 14, 16, 18, 20, 22, 24, 26, 28, 30

34-14 87th Street [1447/12]

34-18 87th Street [1447/14]

34-22 87th Street [1447/16]

34-24 87th Street [1447/18]

34-26—34-32 87th Street [1447/20]

34-34 87th Street [1447/22]

34-38 87th Street [1447/24]

34-42 87th Street [1447/26]

34-46 87th Street [1447/28]

34-50 87th Street [1447/30]

Type: Semi-Detached Houses (10 buildings)

Stories: 3

Style: Anglo-American Garden Home

Date: 1926*

Architect: Robert Tappan

Developer: Queensboro Corp.

*Nos. 34-14 and 34-18 87th Street — NB 1044-1926

*Nos. 34-22 and 34-24 87th Street — NB 1045-1926

*Nos. 34-26—34-32 and 34-34 87th Street — NB 483-1926

*Nos. 34-38 and 34-42 87th Street — NB 1046-1926

*Nos. 34-46 and 34-50 87th Street — NB 1047-1926

Built in 1926 to designs by Robert Tappan, this group of ten houses is characteristic of many similar groups of attached and semi-detached houses built in Jackson Heights during the second half of the 1920s. Located on 87th Street between 34th and 35th avenues, the houses are arranged as five double houses. These houses are very similar to the five double houses at **34-15--34-51 86th Street** which were also designed by Tappan and built at roughly the same time; the two groups are situated back-to-back on the block. Each house has an attached garage at the side and shares a short driveway with the neighboring house in the adjacent pair. All of the houses have front gardens.

The five double houses on 87th Street are arranged in an overall symmetrical pattern ("A-B-C-B-A") with the two houses in each pair designed as mirror images. The pattern of the facade designs is created by the alternating roof profiles and by the form and placement of the projecting entrance porches. The outer "A" pairs have gabled roofs with end chimneys and a shared entrance porch with a hipped roof at the center of the pair. The "B" pairs have hipped roofs with a chimney at the center and separate entrance porches with segmental pediments. The central "C" pair has a gabled roof with end chimneys and a shared projecting entrance porch with a steep gabled roof and entrances at the side.

Of red brick with white trim, the houses are largely neo-Georgian in style. Elements typical of that style include the slate roofs with dormers and prominent chimneys; the classically-inspired entrance porches and the leaded transoms above the doors; the brickwork suggestive of quoins; the wooden shutters at the windows; the arched window openings at the side facades of the "C" houses; the multi-pane double-hung sash, in single and tripartite configurations; and the brick garden walls between the houses and flanking the driveways.

Alterations include replacement entrance and garage doors, although many of these elements, as well as most of the original windows and all of the leaded transoms, remain intact. At the rear, the houses have individual gardens.



34-14—34-50 87th Street

Block 1447 Lots 12, 14, 16, 18, 20, 22, 24, 26, 28 & 30

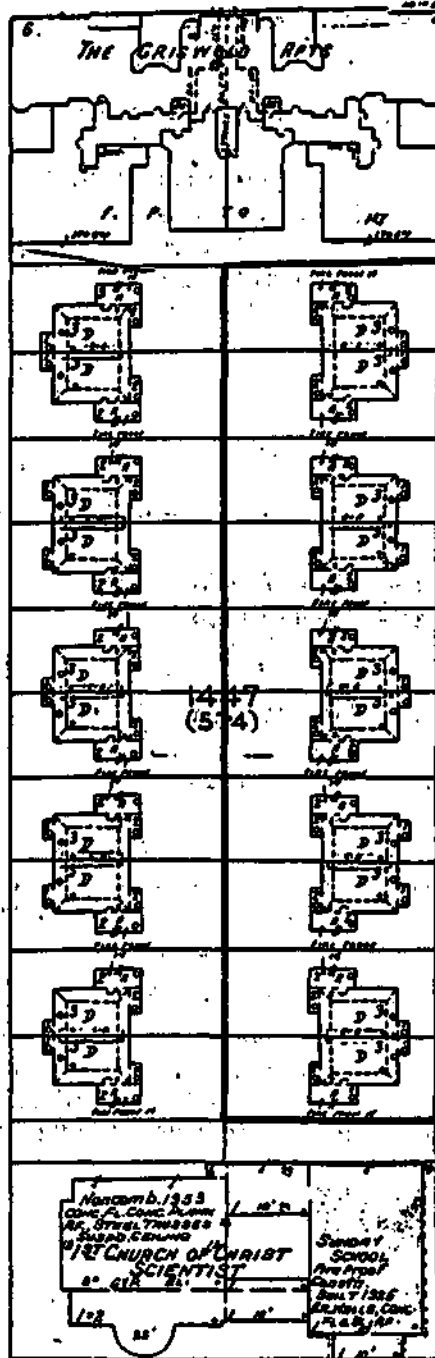

34-14 87th Street [1447/12]

34-18 87th Street [1447/14]

34-22 87th Street [1447/16]

34-24 87th Street [1447/18]

34-26—34-32 87th Street [1447/20]

34-34 87th Street [1447/22]

34-38 87th Street [1447/24]

34-42 87th Street [1447/26]

34-46 87th Street [1447/28]

34-50 87th Street [1447/30]

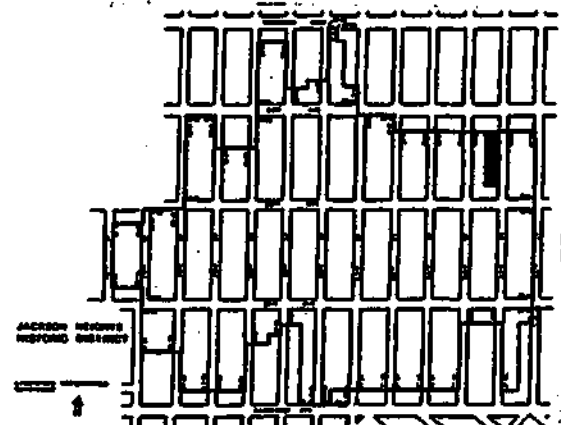

87th Street between 35th Avenue and 37th Avenue (West Side)

35-02 87th Street

See: 86-02—86-06 35th Avenue

87th Street between 35th Avenue and 37th Avenue (West Side)

35-16—35-56 87th Street

Block/lots: 1460/12, 14, 15, 17, 18, 20, 21, 23, 24, 26, 27, 29, 30, 32

35-16 87th Street [1460/12]

35-18 87th Street [1460/14]

35-22 87th Street [1460/15]

35-24 87th Street [1460/17]

35-28 87th Street [1460/18]

35-30 87th Street [1460/20]

35-34 87th Street [1460/21]

35-36 87th Street [1460/23]

35-40 87th Street [1460/24]

35-44 87th Street [1460/26]

35-48 87th Street [1460/27]

35-50 87th Street [1460/29]

35-54 87th Street [1460/30]

35-56 87th Street [1460/32]

Type: Semi-Detached Houses (14 buildings)

Stories: 3

Style: Anglo-American Garden Home

Date: 1926*

Architects: C.F. & D.E. McAvoy

Owners: Queensboro Corp., James McDougall

*Nos. 35-16 and 35-18 87th Street — NB 437-1926

*Nos. 35-22 and 35-24 87th Street — NB 439-1926

*Nos. 35-28 and 35-30 87th Street — NB 441-1926

*Nos. 35-34 and 35-36 87th Street — NB 443-1926

*Nos. 35-40 and 35-44 87th Street — NB 445-1926

*Nos. 35-48 and 35-50 87th Street — NB 447-1926

*Nos. 35-54 and 35-56 87th Street — NB 449-1926

Built in 1926 to designs by C.F. & D.E. McAvoy, this group of fourteen houses is characteristic of many similar groups of attached and semi-detached houses built in Jackson Heights during the second half of the 1920s. Located on the west side of 87th Street between 35th and 37th avenues, the houses are arranged as seven double-houses. All of the houses have front gardens.

The seven pairs of houses are arranged in an overall symmetrical pattern ("A-B-C-A-C-B-A"); the "A" houses have different designs ("a-b"), while the "B" and "C" houses are mirror images. The pattern is created by alternating roof profiles. The "A" pairs have front-facing gables in the "a" model, and hipped roofs with jerkin ends and front-facing shed dormers in the "b" model; the "B" pairs have peaked wall dormers and bracketed entrance canopies; and the "C" houses are identical to the "b" model in the "A" pairs, except that the "a" has a square-headed door and the "C" door has a segmental head.

The design of the houses is derived primarily from the neo-Tudor style. Elements typical of the style include the massing of the shingled roofs, particularly the steep gables; half-timbering ("a" and "B" models); drip moldings over the entrances; and bracketed flower boxes ("b" and "C" models). Almost all the original six-over-six double-hung wood sash windows survive behind storm sash, as do the paneled wood doors with multi-pane sash in the upper section.

The side facades have projecting chimneys and large projecting wooden bay windows at the first story (some have been refaced). Behind the houses, visible from the street, are paired garages, one per house, which are designed with brick siding and slate roofs to match the houses. There is a narrow common driveway from 87th Street.

→

35-16—35-56 87th Street

Block 1460 Lots 12, 14, 15, 17, 18, 20, 21, 23, 24, 26, 27, 29, 30 & 32

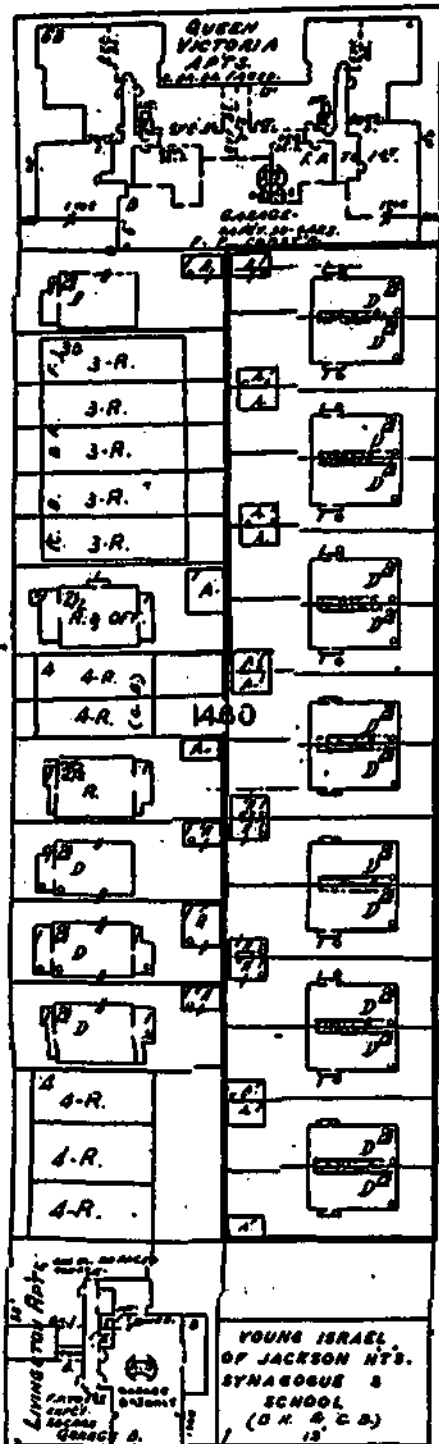

- 35-16 87th Street [1460/12]
- 35-18 87th Street [1460/14]
- 35-22 87th Street [1460/15]
- 35-24 87th Street [1460/17]
- 35-28 87th Street [1460/18]
- 35-30 87th Street [1460/20]
- 35-34 87th Street [1460/21]
- 35-36 87th Street [1460/23]
- 35-40 87th Street [1460/24]
- 35-44 87th Street [1460/26]
- 35-48 87th Street [1460/27]
- 35-50 87th Street [1460/29]
- 35-54 87th Street [1460/30]
- 35-56 87th Street [1460/32]

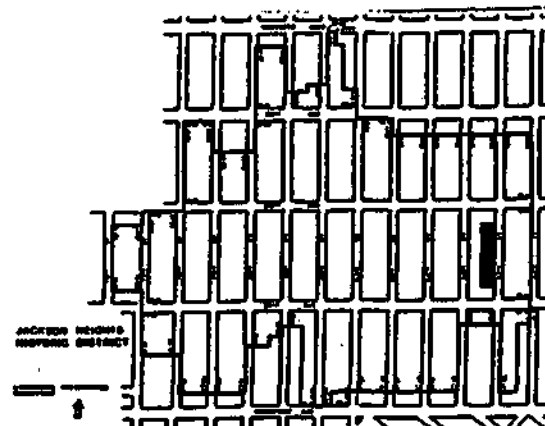

87th Street between 37th Avenue and Roosevelt Avenue (West Side)

37-02—37-10 87th Street

See: 86-02—86-20 37th Avenue

88TH STREET — West Side

88th Street between 34th Avenue and 35th Avenue (West Side)

34-14—34-50 88th Street

Block/lots: 1448/12, 14, 15, 16, 17, 18, 20, 21, 22, 23, 24, 26, 27, 28, 29, 30, 31

34-14 88th Street [1448/12]
34-16 88th Street [1448/14]
34-18 88th Street [1448/15]
34-20 88th Street [1448/16]
34-22 88th Street [1448/17]
34-24 88th Street [1448/18]
34-28 88th Street [1448/20]
34-30 88th Street [1448/21]

34-32 88th Street [1448/22]
34-34 88th Street [1448/23]
34-36 88th Street [1448/24]
34-38 88th Street [1448/26]
34-42 88th Street [1448/27]
34-44 88th Street [1448/28]
34-46 88th Street [1448/29]
34-48 88th Street [1448/30]
34-50 88th Street [1448/31]

Type: Attached & Semi-Detached Houses
(17 buildings)

Stories: 2

Style: Anglo-American Garden Home

Date: 1925-26*

Architect: C.L. Varrone

Developer: Burnetti & Corrizzi

*Nos. 34-14, 34-16, 34-18, 34-20, 34-22, and 34-24 88th Street — NB 19444-1925

*Nos. 34-28, 34-30, 34-32, 34-34, and 34-36 88th Street — NB 19443-1925

*Nos. 34-38, 34-42, 34-44, 34-46, 34-48, and 34-50 88th Street — NB 19442-1925

Built in 1925-26 to designs by C.L. Varrone, this group of seventeen houses is characteristic of many similar groups of attached and semi-detached houses built in Jackson Heights during the second half of the 1920s. Located on 88th Street between 34th and 35th avenues, the houses are arranged in two clusters of six houses each, flanking a central cluster of five houses. Paired garages, one per house, are located at the rear, along a driveway entered and exited at the ends of the blockfront. The group is situated back-to-back with the group at 34-13—34-49 87th Street, designed by Robert Tappan and built in 1925; the two groups together are organized on a block plan, with landscaped open space at the interior of the block. All of the houses have small front gardens.

The clusters are symmetrical in their designs, the two six-house groups following an "a-b-c-c-b-a" pattern and the five-house group following an "a-b-d-b-a" pattern. The houses all have projecting entrance porches in various forms and the "a" and "d" houses have hipped roofs which produce a pavilion-like effect. This also creates the impression that each cluster is a larger single entity and gives the entire blockfront a cohesive patterned design.

The red brick houses are largely neo-Georgian in style, yet their Spanish tile roofs and bracketed window hoods ("c" houses) are more Mediterranean in inspiration. Georgian-inspired elements of the houses include segmentally-arched openings, blind brick arch details, six-over-six double-hung wood sash, and wooden shutters. The side and rear facades of the houses are similar to the fronts, and are partially visible from the street. The rear garages have peaked tile roofs.

Alterations include the replacement of entry doors and garage doors, although many of these features, as well as most of the original windows, remain. No. 34-20 has lost its bracketed window hood. Fences have been added to some of the front gardens.



34-14—34-50 88th Street

Block 1448 Lots 12, 14-18, 20-24, 26-31

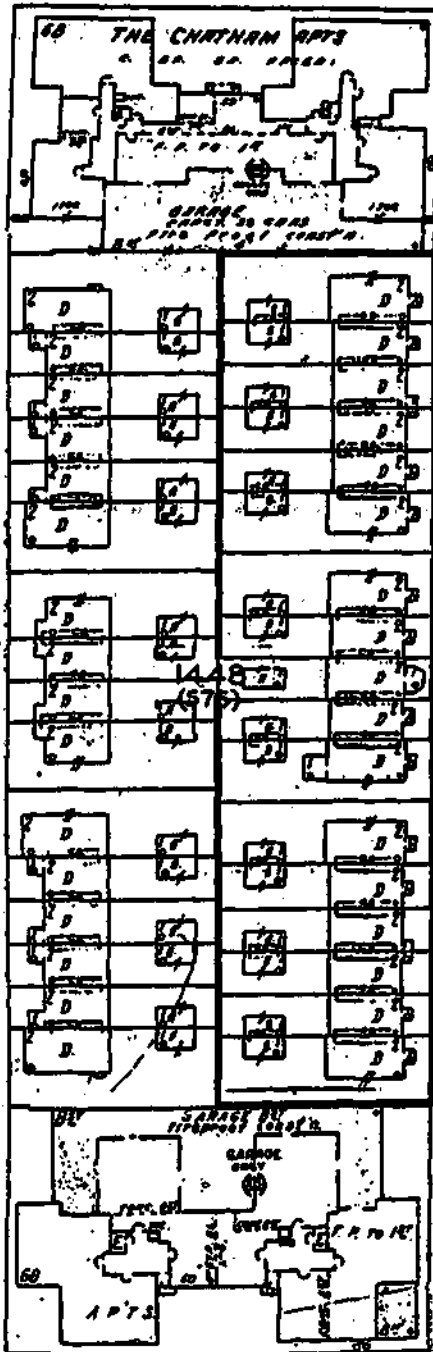

- 34-14 88th Street [1448/12]
- 34-16 88th Street [1448/14]
- 34-18 88th Street [1448/15]
- 34-20 88th Street [1448/16]
- 34-22 88th Street [1448/17]
- 34-24 88th Street [1448/18]

- 34-28 88th Street [1448/20]
- 34-30 88th Street [1448/21]
- 34-32 88th Street [1448/22]
- 34-34 88th Street [1448/23]
- 34-36 88th Street [1448/24]

- 34-38 88th Street [1448/26]
- 34-42 88th Street [1448/27]
- 34-44 88th Street [1448/28]
- 34-46 88th Street [1448/29]
- 34-48 88th Street [1448/30]
- 34-50 88th Street [1448/31]

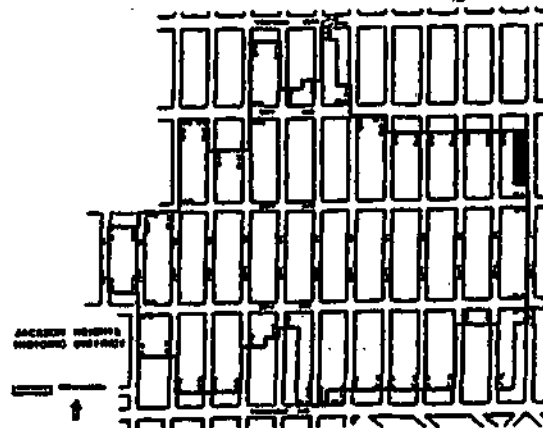

88th Street between 35th Avenue and 37th Avenue (West Side)

THE MADISON APARTMENTS

35-02—35-06 88th Street

Block/lot: 1461/6

Type: Apartment Building

Stories: 6 with basement

Style: Neo-Georgian

Date: 1937 [NB 577-1937]

Architect: Cohn Brothers

Developer: David Isaacowitz & Sons

Built in 1937 to designs by the Cohn Brothers, the six-story-and-basement Madison Apartments is among the later apartment buildings erected in the historic district. Typical of that phase of development, the building occupies an end-block site on 35th Avenue and is planned with a large, recessed entrance court at the front (oriented toward 88th Street) and a shallow recess on the avenue in which there is a full-height three-sided bay. The building shares its 35th Avenue frontage with the **Jacksonian Apartments** to the west, also designed by the firm of Cohn Brothers and built in the previous year.

Neo-Georgian in style, the building is faced in brick with white trim and is similar to other examples of the Cohn firm's work within the historic district. Elements which are typical of the style include the door surround with fluted pilasters and a broken scrolled pediment and the flanking windows with multi-pane arched sash; brickwork imitating quoins and brick band courses; relieving arches with stone false fanlights; stone keystones; monumental temple front motifs applied at the upper stories, culminating at the roofline in triangular pediments with oculi; and parapet balustrades.

88th Street between 35th Avenue and 37th Avenue (West Side)

35-14—35-56 88th Street

Block/lots: 1461/11, 12, 14, 15, 16, 17, 18, 19, 21, 22, 23, 24, 26, 27, 28, 29, 30, 31, 32, 33

35-14 88th Street [1461/11]
35-16 88th Street [1461/12]
35-18 88th Street [1461/14]
35-20 88th Street [1461/15]
35-22 88th Street [1461/16]
35-24 88th Street [1461/17]
35-26 88th Street [1461/18]
35-28 88th Street [1461/19]
35-32 88th Street [1461/21]
35-34 88th Street [1461/22]

35-36 88th Street [1461/23]
35-38 88th Street [1461/24]
35-42 88th Street [1461/26]
35-44 88th Street [1461/27]
35-46 88th Street [1461/28]
35-48 88th Street [1461/29]
35-50 88th Street [1461/30]
35-52 88th Street [1461/31]
35-54 88th Street [1461/32]
35-56 88th Street [1461/33]

Type: Attached & Semi-Detached Houses
(20 buildings)

Stories: 3

Style: Anglo-American Garden Home

Date: 1925-26*

Architect: Robert Tappan

Developer: V. Scuderi

*Nos. 35-14, 35-16, 35-18, 35-20, 35-22, 35-24, 35-26, and 35-28 88th Street — NB 8873-1925

*Nos. 35-32, 35-34, 35-36, and 35-38 88th Street — NB 8872-1925

*Nos. 35-42, 35-44, 35-46, 35-48, 35-50, 35-52, 35-54, and 35-56 88th Street — NB 8871-1925

Built in 1925-26 to designs by Robert Tappan, this group of twenty houses is characteristic of many similar groups of attached and semi-detached houses built in Jackson Heights during the second half of the 1920s. Located on the west side of 88th Street between 35th and 37th avenues, the houses are grouped into two clusters of eight houses flanking a central cluster of four houses. The group is situated back-to-back with a group of houses on the east side of 87th Street (Nos. 35-15--35-61), designed by C.F. McAvoy, with which it shares a planned block interior. Paired garages (one per house) are located at the rear and reached by a common driveway. The houses have small front yards and stoops.

The three clusters follow a symmetrical ("A-B-A") pattern in their overall configuration, and each cluster is, in turn, organized in mirror-image formation. The long "A" clusters have projecting end units with front-facing gables which flank six houses with pitched roofs and paired entrance porches, creating a pavilion-like effect. The four houses in the "B" cluster are arranged as two pairs, each of which shares a projecting gabled section containing the entrances to the two separate houses. The mirror-image placement of the entrances reinforces the symmetry of the group, and the overall consistency of the pattern gives the blockfront a cohesive design.

The design of the houses is derived largely from the neo-Georgian style. Elements typical of that style include the patterned brick facing with white trim, the steeply pitched slate roofs with prominent gables, the shed dormers, the pent-roofed entrance porches, and the arched door surrounds containing fanlight transoms. The side facades of the end houses are visible from the street.

Most of the original eight-over-eight double-hung wood sash windows survive behind storm sash. Some of the paneled wood and multi-pane glass doors remain. Iron grille doors have been added to many of the houses.



88th Street between 37th Avenue and Roosevelt Avenue (West Side)

37-02 88th Street

See: 87-02—87-10 37th Avenue

35-14—35-56 88th Street

Block 1461 Lots 11, 12, 14-19, 21-24, 26-33

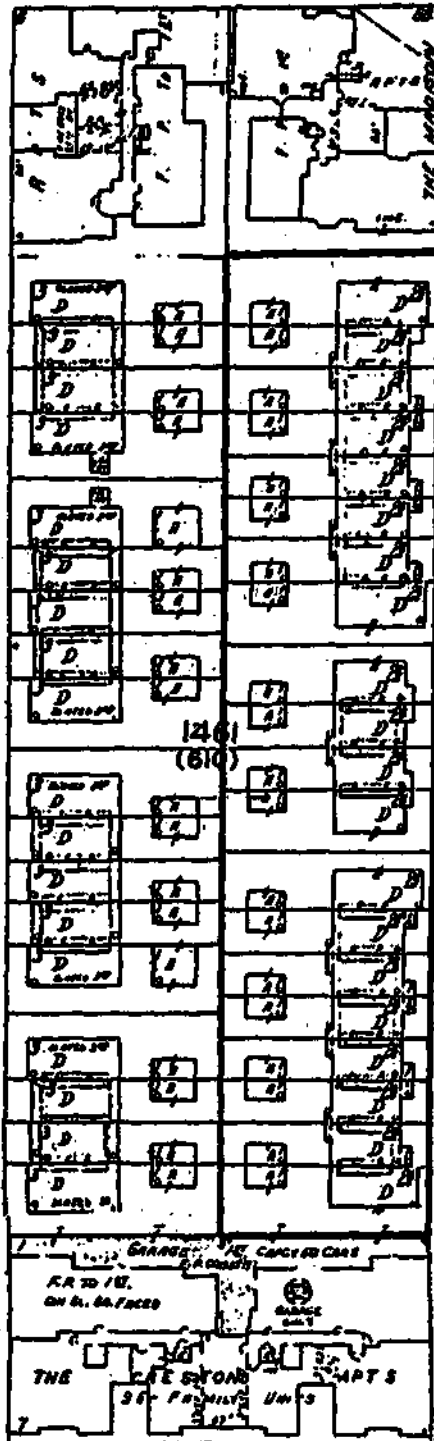

- 35-14 88th Street [1461/11]
- 35-16 88th Street [1461/12]
- 35-18 88th Street [1461/14]
- 35-20 88th Street [1461/15]
- 35-22 88th Street [1461/16]
- 35-24 88th Street [1461/17]
- 35-26 88th Street [1461/18]
- 35-28 88th Street [1461/19]
- 35-32 88th Street [1461/21]
- 35-34 88th Street [1461/22]
- 35-36 88th Street [1461/23]
- 35-38 88th Street [1461/24]
- 35-42 88th Street [1461/26]
- 35-44 88th Street [1461/27]
- 35-46 88th Street [1461/28]
- 35-48 88th Street [1461/29]
- 35-50 88th Street [1461/30]
- 35-52 88th Street [1461/31]
- 35-54 88th Street [1461/32]
- 35-56 88th Street [1461/33]

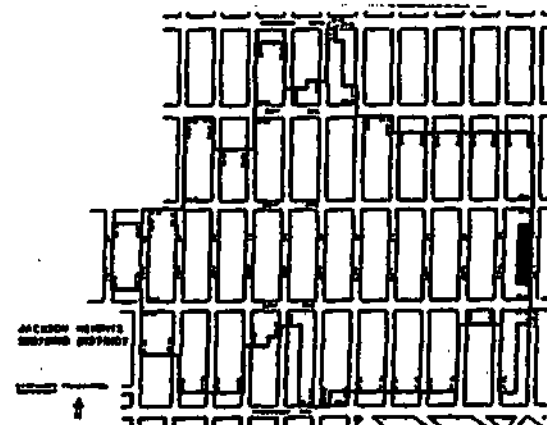

88th Street — West Side

Page intentionally left blank

FINDINGS AND DESIGNATION

On the basis of a careful consideration of the history, the architecture, and other features of this area, the Landmarks Preservation Commission finds that the Jackson Heights Historic District contains buildings and other improvements which have a special character and special historical and aesthetic interest and value and which represent one or more eras in the history of New York City and which cause this area, by reason of these factors, to constitute a distinct section of the city.

The Commission further finds that, among its important qualities, the Jackson Heights Historic District comprises the most cohesive part of an innovative development which was mostly built between the early 1910s and the early 1950s, and which reflects important changes in urban design and planning that took place in the first three decades of the twentieth century; that Jackson Heights was conceived, planned, built in part, and managed under the direction of a single real estate firm, the Queensboro Corporation, and its president Edward A. MacDougall; that the development of Jackson Heights was influenced in its planning and management by a number of sources including the "model tenement" or improved housing movement in New York City at the end of the nineteenth century and the "Garden City" movement at the beginning of this century; that Jackson Heights is one of the earliest neighborhoods in New York City to introduce two new building types, the "garden apartment" complexes of the 1910s and 1920s and the attached and semi-detached "garden homes" which were built after 1924; that the planning and design of these residential building types were innovative in the treatment of the city block as a single unit containing a complex of interrelated buildings arranged around a common landscaped area; that commercial, institutional, entertainment and transportation facilities were integrated with the residential buildings to create an alternative for middle-class residents to the then typical urban neighborhood; that a number of architects worked for the Queensboro Corporation, including the two most influential in the evolution of the garden apartment type, George H. Wells and Andrew J. Thomas; that the earliest projects located within the district, a row of houses (1911) on 83rd Street and a group of walk-up apartment buildings designed by George H. Wells and built between 1913 and 1916 on 82nd Street near the street-car stop on Northern Boulevard, followed in the tradition of late nineteenth-century housing and provide the historical context for understanding the innovative nature of the Queensboro Corporation's later work; that the Greystone Apartments (Wells, 1916-18), composed of two rows of buildings on facing blockfronts of 80th Street which create uniform streetscapes of unbroken masonry facades along both sides of the street, is the first complex in the district to show a substantial reduction in lot coverage and to allocate landscaped open space at the rear of the buildings for common use by the residents; that with the design of Linden Court, built 1919-21, Thomas introduced a planning scheme in which the buildings in the complex are grouped into attached pairs, thus interrupting the building wall on the periphery of the block, and the block's interior is undivided landscaped space held in common by means of easements and deed restrictions; that in 1919, beginning with Linden Court, the Corporation introduced a plan for the cooperative ownership of the buildings in the garden apartment complexes and converted existing rental buildings to cooperatives; that the Queensboro Corporation initiated major garden apartment projects between 1919 and 1924 to the designs of either George H. Wells or Andrew J. Thomas, including Hampton Court, Elm Court, Hawthorne Court, and Laburnum Court by Wells, and the Chateau, Hayes Court, Cambridge Court, the Towers, Ivy Court, Cedar Court, and the Spanish Gardens by Thomas; that the garden apartment buildings in the district, executed in brick, are rendered in a number of architectural styles derived from French, English, Italian, and Spanish sources, generally combining simple facade treatments with such picturesque elements as loggias, belvederes, tile and slate roofs, and decorative brickwork; that the buildings' overall simplicity of design reflects the movement in the first decades of this century away from the extensive use of ornament which had been popular during the late nineteenth century; that the apartment buildings were constructed with a number of features considered novel at the time such as automatic push-button elevators, sun porches, and, at Linden

Court, ground-level garages; that the houses in Jackson Heights, most of which were designed by either Robert Tappan or C.F. & D.E. McAvoy, reflect the influence of the "Garden City" movement and government-sponsored housing developments of the World War I era in their planning and design; that these attached and semi-detached "garden homes," whose design is derived largely from such traditional English sources as Georgian and Tudor architecture, form picturesque ensembles distinguished by varied materials and roof treatments; that the blocks containing the houses were, like the "garden apartments," treated as harmonious design units, with attached houses set back from the building line behind front yards and broken at regular intervals by broad open spaces into pairs or discrete groups of between four and eight houses each; that Jackson Heights is one of New York's earliest communities in which houses were designed with the automobile in mind, and thus garages are included either under the rear of the houses, allowing a block-long greensward at the interior of the block, or garages designed in the styles of the houses line a paved alley laid down the center of the block, or, in the case of some pairs of houses, garages are attached at the side; that the apartment buildings from the 1930s through the 1950s, many of which were constructed along 35th Avenue, are largely six stories in height and characterized by their consistent massing and various planning schemes around lightcourts and courtyards; that these buildings show sensitivity to the existing community in their siting, height, massing, scale, and materials; that many of these later apartment buildings were designed with a modest application of traditional architectural features while others reflect more modernistic trends; that among the architects who worked in Jackson Heights during the post-war period was Philip Birnbaum, a productive New York City architect who contributed several buildings within the historic district, including Roosevelt Terrace; that institutional buildings, including a public school (1924), a post office (1936-37), a branch of the Queens Borough Public Library (1949-52), and several houses of worship, and commercial buildings were also built in Jackson Heights, enhancing the sense of a self-sufficient town within the larger city; that the district is among the earliest areas in the city in which the commercial thoroughfares were planned to complement and integrate with the residential buildings by using the same architectural styles or by incorporating features of adjoining residential buildings into their designs; that the intersection of 37th Avenue, the commercial spine of the district, and 82nd Street, another important commercial street, is distinguished by a group of picturesque neo-Tudor style commercial buildings dating from between the World Wars; that the community at Jackson Heights was recognized at the time of its development as one of New York's important centers of new housing concepts, generating both national and international interest; that many of the ideas and features explored in Jackson Heights are now standard for middle-class housing; and that today, Jackson Heights continues to be a vibrant community which, because of its overall design, planning, and integration of open space, as well as its high degree of intactness, has a strongly defined sense of place.

Therefore, pursuant to Chapter 74, Section 3020 (formerly Chapter 21, Section 534) of the Charter of the City of New York and Chapter 3 of Title 25 of the Administrative Code of the City of New York, the Landmarks Preservation Commission designates as a Historic District the Jackson Heights Historic District in the Borough of Queens consisting of the property bounded by a line beginning at the southeast corner of the intersection of 78th Street and 34th Avenue, then extending southerly along the eastern curbline of 78th Street, westerly along the southern curbline of 35th Avenue, southerly along the eastern curbline of 77th Street, westerly across 77th Street, westerly along the northern property lines of 35-14 77th Street and 35-13 76th Street, southerly along the eastern curbline of 76th Street, easterly along the southern property lines of 35-55 76th Street and 35-56 77th Street, easterly across a portion of 77th Street, southerly along a line extending to the eastern curbline of 77th Street beginning at the southeast corner of 77th Street and 37th Avenue, southerly along the eastern curbline of 77th Street, easterly along the southern property line of 37-01 78th Street (a/k/a 78-02 37th Avenue/37-02 79th Street), easterly across 78th Street, southerly along the eastern curbline of 78th Street, easterly along the southern property lines of 37-57 78th Street and 37-58 79th Street, easterly across 79th Street, easterly along the southern property lines of 37-55 79th Street and 37-52--37-56 80th Street, northerly along the

western curbline of 80th Street, easterly across 80th Street, easterly and northerly along the southern and eastern property lines of 37-15--37-21 80th Street, easterly along the southern property line of 37-20--37-22 81st Street, northerly along the western curbline of 81st Street, easterly across 81st Street, easterly along the southern property lines of 81-02--81-28 37th Avenue (a/k/a 37-01--37-09 81st Street/37-06--37-10 82nd Street), southerly along the western property lines of 37-12--37-34 82nd Street through 37-70 82nd Street (a/k/a 81-11--81-19 Roosevelt Avenue), easterly along the northern curbline of Roosevelt Avenue, northerly along the eastern property line of 82-01 Roosevelt Avenue (a/k/a 37-61--37-67 82nd Street), easterly along the southern property line of 37-60 83rd Street, easterly across 83rd Street, easterly along the southern property line of 32-16--37-58 84th Street (a/k/a 37-15--37-57 83rd Street), easterly across 84th Street, easterly along the southern property lines of 37-55--37-59 84th Street and 37-56--37-60 85th Street, easterly across 85th Street, easterly along the southern property lines of 37-57 85th Street and 37-58 86th Street, northerly along the western curbline of 86th Street, easterly across 86th Street, easterly along the southern property line of 86-02--86-20 37th Avenue (a/k/a 37-01--37-09 86th Street/37-02--37-10 87th Street), easterly across 87th Street, southerly along the eastern curbline of 87th Street, easterly along the southern property line of 35-57 87th Street, northerly along the eastern property lines of 37-57 through 37-11 87th Street, easterly along part of the southern property line of 87-02--87-10 37th Avenue (a/k/a 37-01 87th Street/37-02--37-10 88th Street), northerly along the western curbline of 88th Street, westerly along the northern property lines of 34-14 88th Street and 34-13 87th Street, westerly across 87th Street, westerly along the northern property lines of 34-14 87th Street and 34-15 86th Street, westerly across 86th Street, westerly along the northern property lines of 34-16 86th Street and 34-15--34-41 85th Street, westerly across 85th Street, northerly along the western curbline of 85th Street, westerly along the northern property lines of 34-14 85th Street and 34-11 84th Street, westerly across 84th Street, northerly along the western curbline of 84th Street, westerly along the southern curbline of 34th Avenue, westerly across 83rd Street, northerly along the western curbline of 83rd Street, westerly along the northern property line of 33-54 83rd Street (a/k/a 82-17 34th Avenue), northerly along the eastern property lines of 33-33 82nd Street to 33-11 82nd Street, westerly along the northern property line of 33-11 82nd Street, northerly along the eastern property line of 33-01--33-05 82nd Street, westerly along the southern curbline of Northern Boulevard, southerly along the eastern curbline of 82nd Street, westerly across 82nd Street, westerly, southerly and westerly along the northern property line of 33-50 82nd Street (a/k/a 81-01--81-11 34th Avenue/33-53 81st Street), westerly across 82nd Street, northerly along the western curbline of 81st Street, westerly along the northern property line of 33-16--33-52 81st Street (a/k/a 33-15--33-51 80th Street/80-01 34th Avenue), southerly along the eastern curbline of 80th Street, westerly across 80th Street, westerly along the northern property lines of 34-28 80th Street and 34-27 79th Street, westerly across 79th Street, northerly along the western curbline of 79th Street, westerly along the southern curbline of 34th Avenue to the point of beginning.

78-02—78-20 34th Avenue	79	83-14—83-22 37th Avenue	113
80-01 34th Avenue		84-01—84-09 37th Avenue	105
<i>See: 33-15—33-51 80th Street</i>		84-02—84-30 37th Avenue	113
80-02 34th Avenue		84-11—84-23 37th Avenue	106
<i>See: 34-01—34-47 80th Street</i>		85-01—85-13 37th Avenue	
81-01—81-11 34th Avenue	78	<i>See: 35-65 85th Street</i>	
81-02—81-06 34th Avenue	81	85-02—85-30 37th Avenue	114
81-14—81-20 34th Avenue	82	85-15—85-25 37th Avenue	106
82-01 34th Avenue		86-01—86-13 37th Avenue	106
<i>See: 33-53 82nd Street</i>		86-02—86-20 37th Avenue	114
82-02—82-20 34th Avenue	84	86-15—86-29 37th Avenue	107
83-02 and 83-16 34th Avenue		87-01—87-11 37th Avenue	107
<i>See: 34-01—34-09 83rd Street</i>		87-02—87-10 37th Avenue	115
77-02—77-12 35th Avenue	92	35-13—35-55 76th Street	117
78-01—78-19 35th Avenue		35-01 77th Street	
<i>See: 78-02—78-20 34th Avenue</i>		<i>See: 77-02—77-12 35th Avenue</i>	
78-02—78-12 35th Avenue	92	35-14—35-56 77th Street	
79-01—79-09 35th Avenue	85	<i>See: 35-13—35-55 76th Street</i>	
79-02—79-10 35th Avenue	93	35-25 77th Street	119
79-15 35th Avenue	85	35-53 77th Street	119
80-01—80-19 35th Avenue	86	35-57A—35-59 77th Street	
80-02—80-08 35th Avenue	93	<i>See: 77-01—77-19 37th Avenue</i>	
81-01—81-15 35th Avenue	86	37-01 77th Street	
81-02—82-10 35th Avenue	94	<i>See: 77-02 37th Avenue</i>	
82-01 35th Avenue		34-01—34-41 78th Street	
<i>See: 34-57 82nd Street</i>		<i>See: 78-02—78-20 34th Avenue</i>	
82-15 35th Avenue	87	35-01 78th Street	
83-01—83-09 35th Avenue	88	<i>See: 78-02—78-12 35th Avenue</i>	
83-02—83-12 35th Avenue	99	35-02 78th Street	
84-01—84-19 35th Avenue	90	<i>See: 77-02—77-12 35th Avenue</i>	
84-02—84-12 35th Avenue	99	35-15—35-55 78th Street	122
85-01—85-15 35th Avenue	90	35-24—35-28 78th Street	127
85-02 35th Avenue		35-50 78th Street	127
<i>See: 35-01—35-51 85th Street</i>		35-58A—35-60 78th Street	
86-01—86-17 35th Avenue	91	<i>See: 77-01—77-19 37th Avenue</i>	
86-02—86-06 35th Avenue	100	35-63 78th Street	
87-01—87-11 35th Avenue	91	<i>See: 78-01—78-15 37th Avenue</i>	
77-01—77-19 37th Avenue	101	37-01 78th Street	
77-02 37th Avenue	108	<i>See: 78-02 37th Avenue</i>	
78-01—78-15 37th Avenue	101	37-02 78th Street	
78-02 37th Avenue	108	<i>See: 77-02 37th Avenue</i>	
78-17—78-27 37th Avenue	102	37-13—37-57 78th Street	124
79-01—79-27 37th Avenue	102	34-02—34-42 79th Street	
79-02—79-28 37th Avenue	109	<i>See: 78-02—78-20 34th Avenue</i>	
80-01—80-29 37th Avenue	103	34-27—34-49 79th Street	129
80-02—80-28 37th Avenue	110	35-01 79th Street	
81-01—81-19 37th Avenue	104	<i>See: 79-02—79-10 35th Avenue</i>	
81-02—81-10 37th Avenue	110	35-02 79th Street	
81-14—81-28 37th Avenue	111	<i>See: 78-02—78-12 35th Avenue</i>	
82-01—82-21 37th Avenue	104	35-16—35-56 79th Street	
82-02—82-10 37th Avenue	112	<i>See: 35-15—35-55 78th Street</i>	
82-12—82-20 37th Avenue	112	35-21 79th Street	130
83-01—83-27 37th Avenue	105	35-45 79th Street	130
83-02—83-14A 37th Avenue	113	35-63 79th Street	
		<i>See: 79-01—79-27 37th Avenue</i>	

35-64 79th Street		35-59—35-61 81st Street	
<i>See: 78-17—78-27 37th Avenue</i>		<i>See: 81-01—81-19 37th Avenue</i>	
37-01—37-05 79th Street		35-64 81st Street	
<i>See: 79-02 37th Avenue</i>		<i>See: 80-01—80-29 37th Avenue</i>	
37-02 79th Street		37-01—37-09 81st Street	
<i>See: 78-02 37th Avenue</i>		<i>See: 81-02—81-10 37th Avenue</i>	
37-15—37-31 79th Street	131	37-06 81st Street	
37-16—37-58 79th Street		<i>See: 80-02—80-28 37th Avenue</i>	
<i>See: 37-13—37-57 78th Street</i>		37-20—37-22 81st Street	148
37-41—37-55 79th Street	133	33-01—33-21 82nd Street	149
33-15—33-51 80th Street	136	33-33 82nd Street	151
34-01—34-47 80th Street	138	33-50 82nd Street	
34-28—34-50 80th Street		<i>See: 81-01—81-11 34th Avenue</i>	
<i>See: 34-27—34-49 79th Street</i>		33-53 82nd Street	151
35-01 80th Street		34-01 82nd Street	
<i>See: 80-02—80-08 35th Avenue</i>		<i>See: 82-02—82-20 34th Avenue</i>	
35-02 80th Street		34-02—34-06 82nd Street	
<i>See: 79-02—79-10 35th Avenue</i>		<i>See: 81-14—81-20 34th Avenue</i>	
35-15—35-55 80th Street	140	34-20—34-24 82nd Street	161
35-16—35-54 80th Street		34-25 82nd Street	154
<i>See: 35-15—35-55 80th Street</i>		34-31—34-51 82nd Street	154
35-63 80th Street		34-44 82nd Street	161
<i>See: 80-01—80-29 37th Avenue</i>		34-57 82nd Street	157
35-64 80th Street		35-02 82nd Street	
<i>See: 79-01—79-27 37th Avenue</i>		<i>See: 81-02—81-10 35th Avenue</i>	
37-01—37-05 80th Street		35-16—35-30 82nd Street	162
<i>See: 80-02—80-28 37th Avenue</i>		35-35 and 35-45 82nd Street	157
37-02—37-06 80th Street		35-35—35-45 82nd Street	157
<i>See: 79-02—79-28 37th Avenue</i>		35-36—35-42 82nd Street	163
37-15—37-21 80th Street	142	35-50 82nd Street	163
37-16—37-32 80th Street		35-51—35-55 82nd Street	158
<i>See: 37-15—37-31 79th Street</i>		35-60 82nd Street	
37-42—37-56 80th Street		<i>See: 81-01—81-19 37th Avenue</i>	
<i>See: 37-41—37-55 79th Street</i>		37-01—37-09 82nd Street	
33-16—33-52 81st Street		<i>See: 82-02—82-10 37th Avenue</i>	
<i>See: 33-15—33-51 80th Street</i>		37-02—37-10 82nd Street	
33-53 81st Street		<i>See: 81-14—81-28 37th Avenue</i>	
<i>See: 81-01—81-11 34th Avenue</i>		37-11—37-39 82nd Street	159
34-01 81st Street		37-12—37-34 82nd Street	164
<i>See: 81-02—81-06 34th Avenue</i>		37-36—37-40 82nd Street	164
34-02—34-48 81st Street		37-41—37-45 82nd Street	159
<i>See: 34-01—34-47 80th Street</i>		37-42—37-50 82nd Street	165
34-31 81st Street	144	37-47—37-59 82nd Street	160
34-49 81st Street		37-52—37-58 82nd Street	165
<i>See: 81-01—81-15 35th Avenue</i>		37-60 82nd Street	165
35-01 81st Street		37-61—37-67 82nd Street	
<i>See: 81-02—81-10 35th Avenue</i>		<i>See: 82-01—82-19 Roosevelt Avenue</i>	
35-02 81st Street		37-66 82nd Street	166
<i>See: 80-02—80-08 35th Avenue</i>		37-68—37-80 82nd Street	
35-21—35-27 81st Street	145	<i>See: 81-11—81-19 Roosevelt Avenue</i>	
35-30 81st Street	147	33-54 83rd Street	
35-35—35-45 81st Street	145	<i>See: 33-53 82nd Street</i>	
35-50 81st Street	147	34-01—34-09 83rd Street	167
35-51 81st Street	145	34-02—34-06 83rd Street	
		<i>See: 82-02—82-20 34th Avenue</i>	

34-15—34-51 83rd Street	169	35-02 85th Street	
34-20 83rd Street	176	<i>See: 84-02—84-12 35th Avenue</i>	
34-24 83rd Street		35-16 85th Street	
<i>See: 34-25 82nd Street</i>		<i>See: 35-15 84th Street</i>	
34-32—34-50 83rd Street	177	35-20—35-50 85th Street	
35-01—35-15 83rd Street		<i>See: 35-01—35-51 85th Street</i>	
<i>See: 83-02—83-12 35th Avenue</i>		35-65 85th Street	195
35-33 83rd Street	172	37-01 85th Street	
35-36—35-40 83rd Street	179	<i>See: 85-02—85-30 37th Avenue</i>	
35-49 83rd Street	172	37-02 85th Street	
35-54—35-56 83rd Street		<i>See: 84-02—84-30 37th Avenue</i>	
<i>See: 35-51—35-55 82nd Street</i>		37-12—37-60 85th Street	
35-61 83rd Street		<i>See: 37-11—37-59 84th Street</i>	
<i>See: 83-01—83-27 37th Avenue</i>		37-13—37-57 85th Street	196
35-64 83rd Street		34-15—34-51 86th Street	200
<i>See: 82-01—82-21 37th Avenue</i>		34-16—34-52 86th Street	207
37-01—37-09 83rd Street		35-02 86th Street	
<i>See: 83-02—83-14A 37th Avenue</i>		<i>See: 35-01—35-51 85th Street</i>	
37-02—37-10 83rd Street		35-15, 35-29, 35-37, 35-41, 35-45 and	
<i>See: 82-12—82-20 37th Avenue</i>		35-49 86th Street	202
37-15—37-57 83rd Street	173	35-17—35-25 86th Street	204
37-16—37-20 83rd Street	179	35-33—35-35 86th Street	204
37-30 83rd Street	180	35-53—35-57 86th Street	204
37-46—37-60 83rd Street	181	35-65 86th Street	206
37-62—37-66 83rd Street		37-01—37-09 86th Street	
<i>See: 82-01—82-19 Roosevelt Avenue</i>		<i>See: 86-02—86-20 37th Avenue</i>	
34-02—34-10 84th Street		37-02 86th Street	
<i>See: 34-01—34-09 83rd Street</i>		<i>See: 85-02—85-30 37th Avenue</i>	
34-11—34-51 84th Street	183	37-14—37-58 86th Street	
34-16—34-52 84th Street		<i>See: 37-13—37-57 85th Street</i>	
<i>See: 34-15—34-51 83rd Street</i>		34-13—34-49 87-02 35th Avenue	
35-01 84th Street		<i>See: 35-01—35-05 87th Street</i>	
<i>See: 84-02—84-12 35th Avenue</i>		87th Street	210
35-02—35-16 84th Street		34-14—34-50 87th Street	218
<i>See: 83-02—83-12 35th Avenue</i>		35-01—35-05 87th Street	212
35-15 84th Street	184	35-02 87th Street	
35-34 84th Street		<i>See: 86-02—86-06 35th Avenue</i>	
<i>See: 83-01—83-27 37th Avenue</i>		35-15—35-61 87th Street	213
35-43 84th Street	186	35-16—35-56 87th Street	220
35-46—35-54 84th Street	190	37-01 87th Street	
35-59—35-67 84th Street		<i>See: 87-02—87-10 37th Avenue</i>	
<i>See: 84-01—84-09 37th Avenue</i>		37-02—37-10 87th Street	
35-64 84th Street		<i>See: 86-02—86-20 37th Avenue</i>	
<i>See: 83-01—83-27 37th Avenue</i>		37-11—37-57 87th Street	216
37-01 84th Street		34-14—34-50 88th Street	223
<i>See: 84-02—84-30 37th Avenue</i>		35-02—35-06 88th Street	225
37-10 84th Street		35-14—35-56 88th Street	226
<i>See: 83-14 37th Avenue</i>		37-02 88th Street	
37-11—37-59 84th Street	187	<i>See: 87-02—87-10 37th Avenue</i>	
37-16—37-58 84th Street		Adelsohn, E.	99, 102, 105, 109
<i>See: 37-15—37-57 83rd Street</i>		Alden Apartments, The	
34-14—34-52 85th Street		35-36—35-40 83rd Street	179
<i>See: 34-11—34-51 84th Street</i>		Allendale Apartments	
34-15—34-41 85th Street	192	34-20—34-24 82nd Street	161
35-01—35-51 85th Street	193		

Arlington Hall		Elbertson Apartments, The	
79-01—79-09 35th Avenue	85	79-15 35th Avenue	85
Atcuri, T.	190	Eldorado Apartments, The	
Belvedere Gardens (West and East)		37-15—37-21 80th Street	142
35-15 84th Street and 35-16 85th Street	184	Elkind, Michael M.	195
Belvedere, The		Elm Court	
84-02—84-12 35th Avenue	99	34-27—34-49 79th Street and 34-28—34-50	
Berkeley Apartments		80th Street	129
35-25 77th Street	119	English Gables	
Berkeley Gardens		37-12—37-34 82nd Street	164
77-02—77-12 35th Avenue	92	Fakler, Leo D.	104
Berkeley Hall/(now) Berkeley Gardens		Fakler/Eliason Assoc.	104, 204
77-02—77-12 35th Avenue	92	Faulkner, C.	91
Birnbaum, Philip	81, 86, 93, 127, 151, 192, 193	Fein, Jack	107
Bloch & Hesse	154	Feldman, Hyman I.	90, 100
Brentwood Hall		Fellheimer & Wagner	116
35-50 81st Street	147	Fillmore Hall	
Brunner, Arnold W.	91	83-02—83-12 35th Avenue	99
Cambridge Court		Finchley Apartments, The	
37-13—37-57 85th Street and		35-30 81st Street	147
37-14—37-58 86th Street	196	First Church of Christ, Scientist	
Cantor, M.A.	113, 116	86-01—86-17 35th Avenue	91
Carlton House		Fishkin, Julius	115, 127
34-15—34-41 85th Street	192	Flournoy, Benjamin C.	108
Cedar Court		Franklin, Bates & Heindsmann	179
83-01—83-09 35th Avenue	88	Genard, The/(now) The Jackson	
Chateau, The		35-50 78th Street	127
34-01—34-47 80th Street and		Georgian Gardens	
34-02—34-48 81st	138	34-57 82nd Street	157
Chemical Bank		Georgian Hall	
81-11—81-19 Roosevelt Avenue	116	83-01—83-27 37th Avenue	105
Cohen, Jack Z.	166	Greenbrier Apartments, The	
Cohn Brothers	85, 86, 113, 144, 157, 161, 172, 176, 179, 212, 225	35-49 83rd Street	172
Cohn, B.	130	Greystone Apartments, The	
Colonial Apartments		35-15—35-55 80th Street	
34-31—34-51 82nd Street	154	and 35-16—35-54 80th Street	140
Colonial Arms		Hamilton Court	
34-20 83rd Street	176	37-41—37-55 79th Street	133
Community United Methodist Church Complex		Hamilton, H.	133
81-02—82-10 35th Avenue	94	Hampshire HOUSE	
Corn Exchange Bank/(now) Chemical Bank		35-45 79th Street	130
81-11—81-19 Roosevelt Avenue	116	Hampton Court	
Creston Arms, The		35-15—35-55 78th Street	122
87-01—87-11 37th Avenue	107	Hawthorne Court	
Delano, The		35-13—35-55 76th Street	117
34-44 82nd Street	161	Hayes Court	
Dorfman, Boris	106, 164, 172	33-53 82nd Street	151
Dreisler, Jr., Benjamin	124	Hirsch, M.	165
Dunolly Gardens		Hohausser, William	130
78-02—78-20 34th Avenue	79	Holden McLaughlin & Assoc.	94
East Gate		Horn, Max	114
See: 35-51—35-55 82nd Street		Ivy Court	
Eccles, Alfred H.	84	34-01—34-09 83rd Street and	
		34-02—34-10 84th Street	167

Jackson Heights Post Office 78-02 37th Avenue	108	82-02—82-04 Northern Boulevard <i>See: 33-01—33-21 82nd Street</i>	
Jackson House, The 35-53 77th Street	119	Oak Hall (West and East) 35-33 83rd Street and 35-34 84th Street	172
Jackson, The 35-50 78th Street	127	Oban Court and Penrhyn Court 81-14—81-20 34th Avenue	82
Jacksonian Apartments, The 37-20—37-22 81st Street	148	Pauldor Court/(now) The Jackson House 35-53 77th Street	119
35-01—35-05 87th Street	212	Peck, Charles	160, 181
Jefferson Hall Apartments, The 78-02—78-12 35th Avenue	92	Penrhyn Court <i>See Oban Court,</i> 81-14—81-20 34th Avenue	82
Jewish Center of Jackson Heights, The 34-25 82nd Street	154	Platt, F.P.	94
Junge, James D.	177	Plymouth Apartments 35-16—35-30 82nd Street	162
Kavy & Kavovitt	91, 110, 163	Plymouth Houses 34-15—34-51 83rd Street and 34-16—34-52 84th Street	169
Keller, S.	145	Prober & Blaufeux	142
Kiesewetter, Pierce L.	169	Public School 69 77-02 37th Avenue	108
Laburnum Court 37-15—37-31 79th Street	131	Queen Elizabeth 85-01—85-15 35th Avenue	90
LaPierre & Litchfield	96	Queen Victoria Apartments 86-02—86-06 35th Avenue	100
Laurel Court 33-01—33-21 82nd Street	149	Queens Borough Public Library — Jackson Heights Branch 35-51 81st Street	145
Lawrence House Apartments 81-02—81-06 34th Avenue	81	Queensboro Corporation Headquarters (former) 78-17—78-27 37th Avenue	102
Lawrence Terrace Apartments 33-33 82nd Street	151	81-14—81-28 37th Avenue	111
Lenz & Berger	101	Ravenna Court 80-01—80-29 37th Avenue	103
Lincoln Apartments, The 87-01—87-11 35th Avenue	91	Ricca & Ungaleider	145
Linden Court 37-11—37-59 84th Street and 37-12—37-60 85th Street	187	Robert Morris Apartments 79-02—79-28 37th Avenue	109
Litchfield, Apartments, The 35-43 84th Street	186	Rogers & Haneman	103, 207
Livingston Apartments 35-65 86th Street	206	81-11—81-19 Roosevelt Avenue	116
Lubrott, J.	110	82-01 Roosevelt Avenue	116
Lukowsky, R.	165	Roosevelt Terrace 35-01—35-51 85th Street and 35-20—35-50 85th Street	193
Madison Apartments, The 35-02—35-06 88th Street	225	Rothstein & Son, Morris	119
Maple Court 35-21—35-27 81st Street	145	Rothstein, Morris	90
McAvoy, C.F.	213, 216	Saint Joan of Arc R.C. Church Complex 35th Avenue between 82nd and 83rd Streets	96
McAvoy, C.F. & D.E.	220	Saint Mark's Episcopal Church 81-01—81-11 34th Avenue	78
Miller & Goldhammer	158	Salemi, G.	105
Mok, Paul	104	Schlusing, W.A.	96
Monroe House 35-21 79th Street	130	Schulman & Soloway	206
Monterey Apartments, The 37-30 83rd Street	180	Seelig & Finkelstein . 87, 107, 112, 148, 180, 184	
Mount Vernon Apartments 34-31 81st Street	144		
Murphy & Lehman	96		
Murphy, Henry V.	96		
Murphy, Henry V.	96		

Senate Gardens		Ungaleider, M.E.	145
82-15 35th Avenue	87	Urbahn Associates	108
Shampan & Shampan	113, 114	Varrone, C.L.	223
Silverstone, Oscar I.	93, 101	Verona Court	
Smith, Morrell	111	79-01--79-27 37th Avenue	102
Snyder, C.B.J.	108	Wakefield Apartments, The	
Sohn & Weston	147	35-35--35-45 81st Street	145
Spanish Gardens		Weinstein, M.N.	147
37-15--37-57 83rd Street and		Wells, George H.	82, 112, 117, 122, 129, 131,
37-16--37-58 84th Street	173	140, 149, 154, 157, 162, 196	
Stein, J.	154	West Gate and East Gate	
Steinback, Gustave E.	96	35-51--35-55 82nd Street	158
Stephen Hall Apartments		Westleigh Apartments	
35-36--35-42 82nd Street	163	84-01--84-19 35th Avenue	90
Stidolph, Charles	202	William Penn Apartments, The	
Stratford Hall		79-02--79-10 35th Avenue	93
80-01--80-19 35th Avenue	86	Willow Court	
Sussex House		35-35--35-45 82nd Street	157
87-02--87-10 37th Avenue	115	Winslow Apartments	
Tabatchnik, Joshua	85, 92, 99, 119, 161, 186	80-02--80-08 35th Avenue	93
Tappan, Robert	78, 164, 183, 200, 210, 218, 226	Woodstock Apartments, The	
Thomas, Andrew J.	79, 88, 102, 136, 138,	81-01--81-15 35th Avenue	86
	151, 167, 173, 187	Young Israel of Jackson Heights	
Towers, The		86-15--86-29 37th Avenue	107
33-15--33-51 80th Street	136	Zelnik, Simon B.	159